

DAILY REFERENCE GUIDE



THANK YOU FOR PURCHASING A BAUKNECHT PRODUCT

To receive more comprehensive help and support, please register your product at www.bauknecht.eu/register



You can download the Safety Instructions and the Use and Care Guide by visiting our website docs.bauknecht.eu and following the instructions on the back of this booklet.



Before using the appliance carefully read the Health and Safety guide.

PRODUCT DESCRIPTION

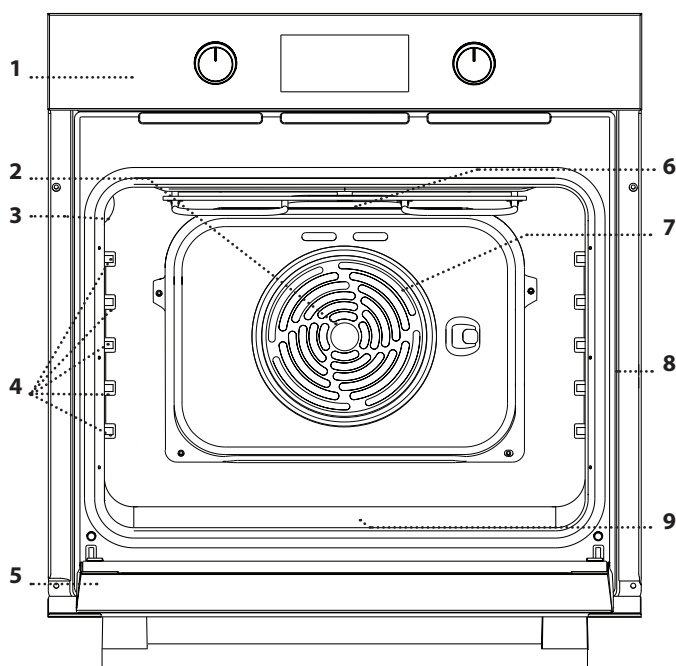

1. Control panel
2. Fan
3. Lamp
4. Shelf guides
(the level is indicated on the wall of the cooking compartment)
5. Door
6. Upper heating element / grill
7. Circular heating element
(not visible)
8. Identification plate
(do not remove)
9. Bottom heating element
(not visible)

CONTROL PANEL

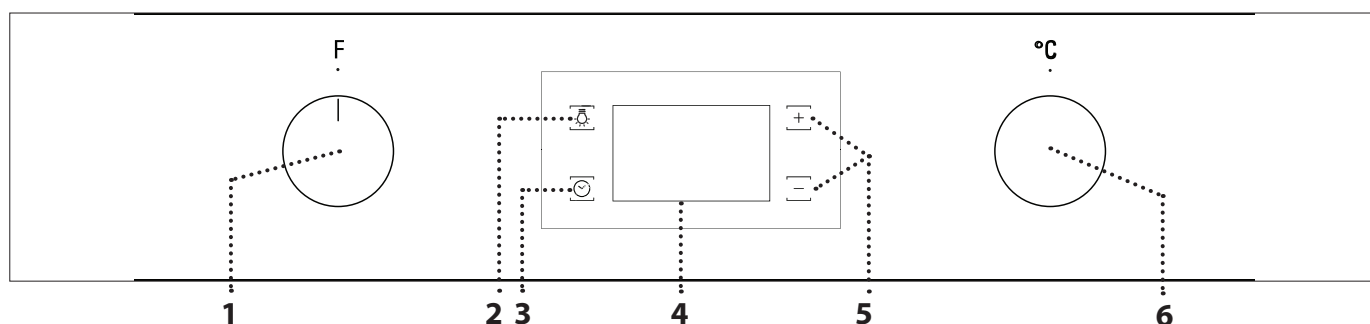

1. SELECTION KNOB

For switching the oven on by selecting a function. Turn to the 0 position to switch the oven off.

2. LIGHT

With the oven switched on, press to turn the oven compartment lamp on or off.

3. SETTING THE TIME

For accessing the cooking time settings, delayed start and timer. For displaying the time when the oven is off.

4. DISPLAY

5. ADJUSTMENT BUTTONS

For changing the cooking time settings.

6. THERMOSTAT KNOB

Turn to select the temperature you require when activating manual functions. Automatic functions use 0.

Please note: All knobs are push-activated knobs. Push down on the centre of the knob to release it from its seating.

WIRE SHELF

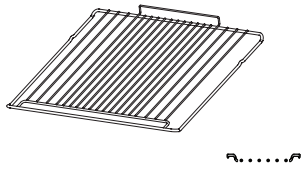

DRIP TRAY

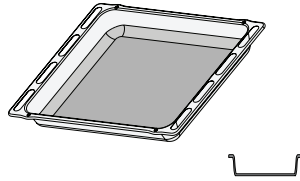

BAKING TRAY

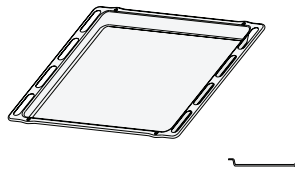

The number of accessories may vary depending on which model is purchased. Other accessories can be purchased separately from the After-sales Service.

INSERTING THE WIRE SHELF AND OTHER ACCESSORIES

• Insert the wire shelf onto the level you require by holding it tilted slightly upwards and resting the raised rear side (pointing upwards) down first. Next, slide it horizontally along the shelf guide as far as possible.

• The other accessories, such as the drip tray and the baking tray, are inserted horizontally by sliding them along the shelf guides.
• The shelf guides can be removed to facilitate the oven cleaning: pull them to remove from their seats.

FUNCTIONS

CONVECTION

For cooking any kind of dish on one shelf only.

FORCED AIR

For cooking different foods that require the same cooking temperature on several shelves (maximum three) at the same time. This function can be used to cook different foods without odours being transferred from one food to another.

MAXI COOKING

For cooking large joints of meat (above 2.5 kg). We recommend turning the meat over during cooking to ensure that both sides brown evenly. We also recommend basting the joint every so often to prevent it from drying out excessively.

PIZZA

For baking different types and sizes of pizza and bread. It is a good idea to swap the position of the baking plates halfway through cooking.

GRILL

For grilling steaks, kebabs and sausages, cooking vegetables au gratin or toasting bread. When grilling meat, we recommend using a drip tray to collect the cooking juices: Position the tray on any of the levels below the wire shelf and add 200 ml of drinking water.

TURBO GRILL

For roasting large joints of meat (legs, roast beef, chicken). We recommend using a drip tray to collect the cooking juices: position the pan on any of the levels below the wire shelf and add 200 ml of drinking water.

RISING

For helping sweet or savoury dough to rise effectively. To maintain the quality of proving, do not activate the function if the oven is still hot following a cooking cycle.

DEFROSTING

For defrosting food more quickly. To activate the defrosting function turn the selection knob to the icon then turn the thermostat knob clockwise to any temperature. This function does not heat so any temperature can be used. When defrosting is completed turn the two controls to the F and °C positions.

ECO FORCED AIR

For cooking roasts and stuffed roasting joints on a single shelf. Food is prevented from drying out excessively by gentle, intermittent air circulation. When this ECO function is in use, the light will remain switched off during cooking but can be switched on again by pressing .

^A BREAD AUTO



This function automatically selects the ideal temperature and baking time for bread. For best results, carefully follow the recipe. Activate the function when the oven is cold.

^A PASTRY AUTO







This function automatically selects the ideal temperature and baking time for cakes. Activate the function when the oven is cold.

USING THE APPLIANCE FOR THE FIRST TIME

1. SETTING THE TIME

You will need to set the time when you switch on the appliance for the first time: press  until the  icon and the two digits for the hour start flashing on the display.



Use  or  to set the hour and press  to confirm. The two digits for the minutes will start flashing. Use  or  to set the minutes and press  to confirm.

Please note: When the  icon is flashing, for example following lengthy power outages, you will need to reset the time.

2. REHEAT THE OVEN

A new oven may release odours that have been left behind during manufacturing: this is completely normal.

Before starting to cook food, we therefore recommend heating the oven with it empty in order to remove any possible odours.

Remove any protective cardboard or transparent film from the oven and remove any accessories from inside it.

Heat the oven to 250 ° C for about one hour, preferably using the "Maxi Cooking" function. The oven must be empty during this time.

Follow the instructions for setting the function correctly.

Please note: It is advisable to air the room after using the appliance for the first time.

DAILY USE

1. SELECT A FUNCTION

To select a function, turn the *selection knob* to the symbol for the function you require: the display will light up and an audible signal will sound.



2. ACTIVATE A FUNCTION

MANUAL

To start the function you have selected, turn the *thermostat knob* to set the temperature you require.

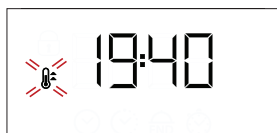

Please note: During cooking you can change the function by turning the *selection knob* or adjust the temperature by turning the *thermostat knob*.

The function will not start if the thermostat knob is on . You can set the cooking time, cooking end time (only if you set a cooking time) and a timer.

AUTOMATIC

To start the automatic function you have selected ("Bread" or "Dessert"), keep the *thermostat knob* at the position for automatic functions ().

To finish cooking, turn the *selection knob* to position 0.

Please note: You can set the cooking end time and timer.

RISING

To start the "Rising" function, turn the *thermostat knob* to the relevant symbol; if the oven is set to a different temperature, the function will not start.

Please note: You can set the cooking time, cooking end time (only if you set a cooking time) and a timer.

3. PREHEATING

Once the function starts, an audible signal and a flashing icon  on the display indicate that the preheating phase has been activated.



At the end of this phase, an audible signal and the fixed icon  on the display will indicate that the oven has reached the set temperature: at this point, place the food inside and proceed with cooking.

Please note: Placing the food in the oven before preheating has finished may have an adverse effect on the final cooking result.



. PROGRAMMING COOKING

You will need to select a function before you can start programming cooking.



DURATION

Keep pressing  until the  icon and "00:00" start flashing on the display.



Use  or  to set the cooking time you require, then press  to confirm.



Activate the function by turning the *thermostat knob* to the temperature you require: an audible signal will sound and the display will indicate that cooking is complete.

Notes: To cancel the cooking time you have set, keep pressing  until the  icon starts flashing on the display, then use  to reset the cooking time to "00:00". This cooking time includes a preheating phase.

PROGRAMMING THE END COOKING TIME/ DELAYED START

After a cooking time has been set, starting the function can be delayed by programming its end time: press  until the  icon and the current time start flashing on the display.



Use  or  to set the time you want cooking to end and press  to confirm.

Activate the function by turning the *thermostat knob* to the temperature you require: the function will remain paused until it starts automatically after the period of time that has been calculated in order for cooking to finish at the time you have set.



Please note: To cancel the setting, switch the oven off by turning the *selection knob* to position "0".

Note: Delay to start functionality is not available for Grill and Turbo Grill functions.

END OF COOKING

An audible signal will sound and the display will indicate that the function has finished.



Turn the *selection knob* to select a different function or to position "0" to switch the oven off.



Please note: If the timer is active, the display will show "END" alternately with the remaining time.

. SETTING THE TIMER

This option does not interrupt or program cooking but allows you to use the display as a timer, either during while a function is active or when the oven is off.

Keep pressing  until the  icon and "00:00" start flashing on the display.









































































Use  or  to set the time you require and press  to confirm.







An audible signal will sound once the timer has finished counting down the selected time.

Notes: To cancel the timer, keep pressing  until the  icon starts flashing, then use  to reset the time to "00:00".

COOKING TABLE

RECIPE	FUNCTION	PREHEAT	TEMPERATURE (°C)	DURATION (MIN)	LEVEL AND ACCESSORIES
Leavened cakes		Yes	160-180	30-90	2/3 
		Yes	160 - 180	30 - 90	4  1 
Filled cake (cheese cake, strudel, fruit pie)		Yes	160-200	35-90	2 
		Yes	160-200	40-90	4  2 
Biscuits/tartlets		Yes	160-180	20-45	3 
		Yes	150 - 170	20 - 45	4  2 
		Yes	150 - 170	20-45	5  3  1 
Choux buns		Yes	180 - 210	30-40	3 
		Yes	180-200	35-45	4  2 
		Yes	180-200	35-45	5  3  1 
Meringues		Yes	90	150 - 200	3 
		Yes	90	140 - 200	4  2 
		Yes	90	140 - 200	5  3  1 
Pizza/bread		Yes	190-250	15-50	1 / 2 
		Yes	190-250	20-50	4  2 
Bread		-	-	60	2 
Frozen pizza		Yes	250	10 - 20	3 
		Yes	230 - 250	10 -25	4  2 
Salty cakes (vegetable pie, quiche)		Yes	180-200	40-55	3 
		Yes	180-200	45 - 60	4  2 
		Yes	180-200	45 - 60	5  3  1 
Vols-au-vents/puff pastry crackers		-	190-200	20-30	3 
		-	180-190	20-40	4  2 
		-	180-190	20-40	5  3  1 

FUNCTIONS								
	Conventional	Grill	Turbo Grill	Pizza	Forced Air	Maxi Cooking	Bread Auto	Eco Forced Air

ACCESSORIES						
	Wire shelf	Baking dish or baking tray on the wire shelf	Drip tray/baking tray on the wire shelf	Drip tray	Drip tray with 200 ml of water	Baking tray

RECIPE	FUNCTION	PREHEAT	TEMPERATURE (°C)	DURATION (MIN)	LEVEL AND ACCESSORIES
Lasagna/baked pasta/cannelloni/flans		Yes	190 - 200	45 - 65	2
Lamb / veal / beef / pork 1 kg		Yes	190 - 200	80 - 110	3
Roast pork with crackling 2 kg		Yes	180-190	110-150	2
Chicken / rabbit / duck 1 kg		Yes	200 - 230	50 - 100	2
Turkey/goose 3 kg		-	190-200	100 - 160	2
Baked Whole Fish (fillet, whole)		Yes	170 - 190	30 - 45	2
Stuffed vegetables (tomatoes, courgettes, aubergines)		Yes	180-200	50 - 70	2
Toasted bread		-	250	2 - 6	5
Fish fillets/slices		-	230 - 250	20 - 30*	4 3
Sausages/kebabs/spare ribs/hamburgers		-	250	15 - 30*	5 4
Roast chicken 1-1.3 kg		Yes	200 - 220	55 - 70**	2 1
Roast beef rare 1 kg		Yes	200 - 210	35 - 50**	3
Leg of lamb/knuckle		Yes	200 - 210	60 - 90**	3
Roast potatoes		Yes	200 - 210	35 - 55**	3
Vegetable gratin		-	200 - 210	25 - 55	3
Meat and potatoes		Yes	190-200	45 - 100***	4 1
Fish and vegetables		Yes	180	30 - 50***	4 1
Lasagne and meat		Yes	200	50 - 100***	4 1
Complete meal: fruit tart (level 5)/ lasagne (level 3)/ meat (level 1)		Yes	180-190	40 - 120***	5 3 1
Roast meat/stuffed roasting joints		-	170 - 180	100 - 150	2

The time indicated does not include the preheating phase: we recommend placing the food in the oven and setting the cooking time only after the required temperature has been reached.

* Turn food halfway through cooking.

** Turn food two-thirds of the way through cooking (if necessary).

*** Estimated length of time: dishes can be removed from the oven at different times depending on personal preference.

Download the Use and Care Guide from docs.bauknecht.eu for the table of tested recipes, compiled for the certification authorities in accordance with the standards IEC and IEC 60350-1.

FUNCTIONS								
	Conventional	Grill	Turbo Grill	Pizza	Forced Air	Maxi Cooking	Bread Auto	Eco Forced Air
ACCESSORIES								
	Wire shelf	Baking dish or baking tray on the wire shelf	Drip tray/baking tray on the wire shelf	Drip tray	Drip tray with 200 ml of water	Baking tray		

MAINTENANCE AND CLEANING



Download the Use and Care Guide from docs.bauknecht.eu for more information

Do not use steam cleaning equipment.

Use protective gloves during all operations.

Carry out the required operations with the oven cold.

Disconnect the appliance from the power supply.

Do not use wire wool, abrasive scourers or abrasive/corrosive cleaning agents, as these could damage the surfaces of the appliance.

EXTERIOR SURFACES

- Clean the surfaces with a damp microfibre cloth. If they are very dirty, add a few drops of pH-neutral detergent. Finish off with a dry cloth.
- Do not use corrosive or abrasive detergents. If any of these products inadvertently comes into contact with the surfaces of the appliance, clean immediately with a damp microfibre cloth.

INTERIOR SURFACES

- After every use, leave the oven to cool and then clean it, preferably while it is still warm, to remove any deposits or stains caused by food residues. To dry any condensation that has formed as a result of cooking foods with a high water content, let the oven to cool completely and then wipe it with a cloth or sponge.

- The door can be easily removed and refitted to facilitate cleaning of the glass. 
- Clean the glass in the door with a suitable liquid detergent.
- The top heating element of the grill can be lowered to clean the upper panel of the oven: Extract the heating element from its seating, then lower it. To return the heating element to its position, lift it up, pull it slightly towards you and make sure that the tab support is in its proper seating.

ACCESSORIES

Soak the accessories in a washing-up liquid solution after use, handling them with oven gloves if they are still hot. Food residues can be removed using a washing-up brush or a sponge.

REMOVING AND REFITTING THE DOOR

1. To remove the door, open it fully and lower the catches until they are in the unlock position.

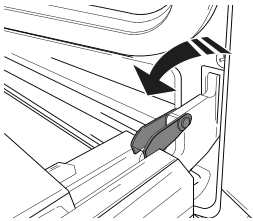

2. Close the door as much as you can. Take a firm hold of the door with both hands – do not hold it by the handle. Simply remove the door by continuing to close it while pulling it upwards (a) at the same time until it is released from its seating (b).

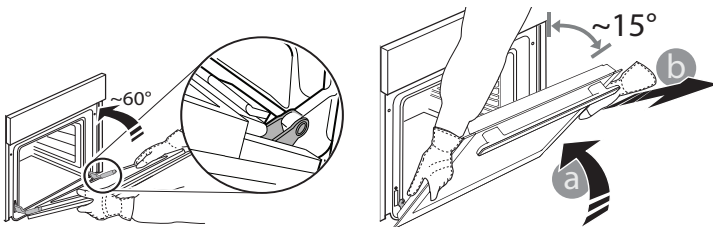

Put the door to one side, resting it on a soft surface.

3. Refit the door by moving it towards the oven, aligning the hooks of the hinges with their seating and securing the upper part onto its seating.

4. Lower the door and then open it fully. Lower the catches into their original position: make sure that you lower them down completely.

5. Try closing the door and check to make sure that it lines up with the control panel. If it does not, repeat the steps above.

CLICK TO CLEAN - CLEANING THE GLASS

1. After removing the door and resting it on a soft surface with the handle downwards, simultaneously press the two retaining clips and remove the upper edge of the door by pulling it towards you.

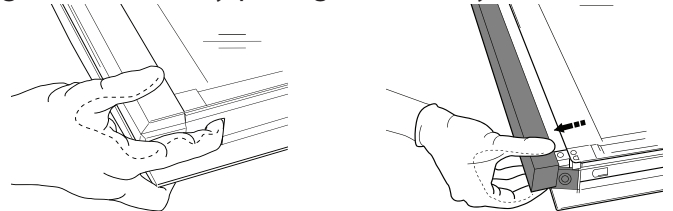

2. Lift and firmly hold the inner glass with both hands, remove it and place it on a soft surface before cleaning it.

3. To correctly reposition the inner glass, make sure that the "R" is visible in the left-hand corner and the clear surface (not printed) is facing up. First insert the long side of the glass indicated by "R" into the support seats, then lower it into position.

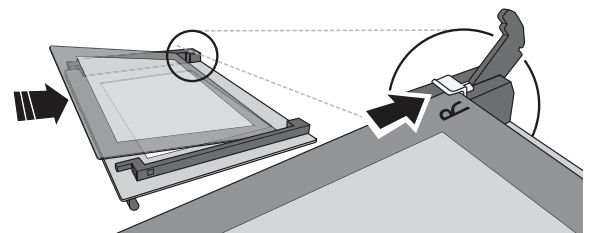

4. Refit the upper edge: a click will indicate correct positioning. Make sure the seal is secure before refitting the door.

Problem	Possible cause	Solution
The oven does not work	Power cut. Disconnection from the mains	Check for the presence of mains electrical power and whether the oven is connected to the electricity supply. Turn off the oven and restart it to see if the fault persists
The display shows the letter "F" followed by a number	Software problem	Contact you nearest After-sales Service Centre and state the letter or number that follows the letter "F"

USEFUL TIPS



Download the Use and Care Guide from docs.bauknecht.eu for more information

HOW TO READ THE COOKING TABLE

The table lists the best function, accessories and level to use to cook different types of food. Cooking times start from the moment food is placed in the oven, excluding preheating (where required). Cooking temperatures and times are approximate and depend on the amount of food and the type of accessory used. Use the lowest recommended settings to begin with and, if the food is not cooked enough, then switch to higher settings. Use the accessories supplied and preferably dark-coloured metal cake tins and baking trays. You can also use Pyrex or stoneware pans and accessories, but bear in mind that cooking times will be slightly longer.

COOKING DIFFERENT FOODS AT THE SAME TIME

Using the "Forced Air" function, you can cook different foods which require the same cooking temperature at the same time (for example: fish and vegetables), using different shelves. Remove the food which requires a shorter cooking time and leave the food which requires a longer cooking time in the oven.

BREAD AUTO FUNCTION

For best results you should carefully follow the instructions, using the recipe for mixing 1000 g of dough: 600 g of flour, 360 g of water, 11 g of salt, 25 g of fresh yeast (or two packets of yeast powder).

For optimal rising, allow about 90 minutes at room temperature or 60 minutes in the oven using the "Proving" function.

Put the dough into the (cold) oven, pour 100 cc of cold drinking water on to the bottom of the oven and activate the "Bread Auto" function. After cooking, leave the dough to stand on a wire shelf until completely cooled.

PRODUCT FICHE

The product fiche with energy data of this appliance can be downloaded from the website docs.bauknecht.eu

HOW TO OBTAIN THE USE AND CARE GUIDE

> Download the Use and Care Guide from our website docs.bauknecht.eu (you can use this QR Code), specifying the product's commercial code.



> Alternatively, contact our Client After-sales Service

CONTACTING OUR AFTER-SALES SERVICE

You can find our contact details in the warranty manual. When contacting our Client After-sales Service, please state the codes provided on your product's identification plate.

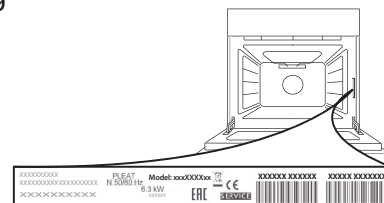

KURZANLEITUNG



**DANKE, DASS SIE SICH FÜR EIN
BAUKNECHT-PRODUKT ENTSCIEDEN HABEN**
Für eine umfassende Hilfe und Unterstützung,
registrieren Sie bitte Ihr Gerät unter
www.bauknecht.eu/register



Die Sicherheitshinweise und
Gebrauchsanleitung können auf unserer
Internetseite docs.bauknecht.eu
runtergeladen werden, bitte die Anweisungen
auf der Rückseite des Heftes befolgen.



Lesen Sie vor Inbetriebnahme des Geräts sorgfältig die Sicherheitshinweise.

PRODUKTBESCHREIBUNG

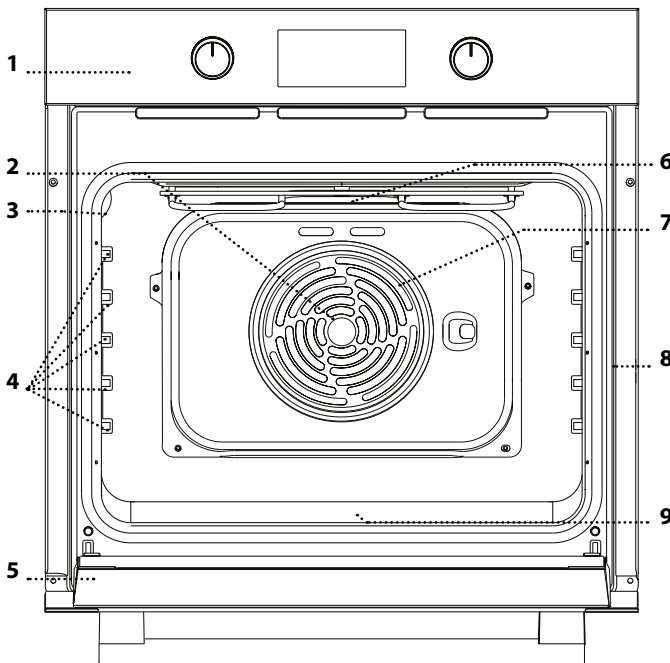

1. Bedienfeld
2. Gebläse
3. Lampe
4. Seitengitter
(die Einschubebene wird auf der
Wand des Garraums angezeigt)
5. Tür
6. Oberes Heizelement/Grill
7. Ringheizelement
(nicht sichtbar)
8. Typenschild
(nicht entfernen)
9. Unteres Heizelement
(nicht sichtbar)

BEDIENTAFEL

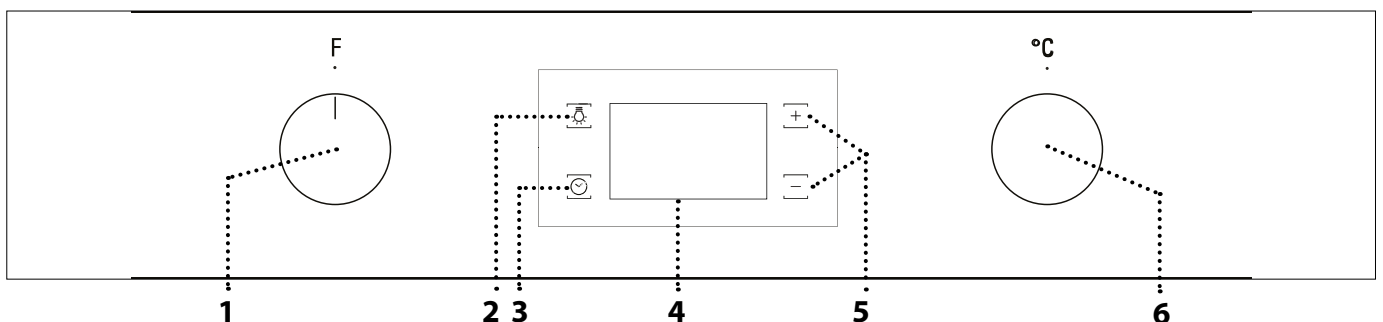

1. AUSWAHLKNOPF

Zum Einschalten des Ofens durch
Funktionsauswahl.
Auf 0 drehen, um den Ofen
auszuschalten.

2. LAMPEN

Bei eingeschaltetem Ofen drücken,
um die Lampe im Garraum ein- oder
auszuschalten.

3. EINSTELLUNG DER UHRZEIT

Für den Zugang zu Garzeiteinstellungen,
Startverzögerung und Timer. Zur
Anzeige der Zeit, wenn der Ofen
ausgeschaltet ist.

4. DISPLAY

5. EINSTELLTASTEN

Zum Ändern der Garzeiteinstellungen.

6. THERMOSTATREGLER

Drehen, um die gewünschte
Temperatur bei Aktivierung
der manuellen Funktionen
auszuwählen. Verwendung der
Automatikfunktionen 0.

Bitte beachten: Alle Knöpfe sind
Druckknöpfe. Den Knopf bis zur Mitte
runter drücken, um ihn aus seinem Sitz zu
lösen.

ROST

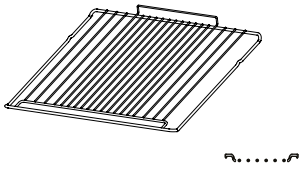

FETTPFANNE

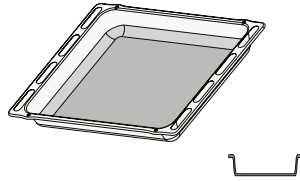

BACKBLECH

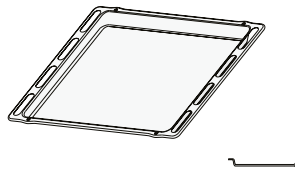

Die Anzahl der Zubehörteile kann je nach gekauftem Modell variieren. Weitere Zubehörteile sind separat über den Kundenservice erhältlich.

DEN ROST UND ANDERE ZUBEHÖRTEILE EINSETZEN

• Den Rost auf die gewünschte Ebene einschieben, ihn dabei leicht nach oben gekippt halten und die angehobene hintere Seite (nach oben zeigend) zuerst nach unten legen. Dann horizontal entlang des Seitengitters so weit wie möglich schieben.

• Die anderen Zubehörteile, wie die Fettpfanne und das Backblech, werden horizontal eingesetzt, indem sie entlang der Seitengitter eingeschoben werden.
• Die Seitengitter können zum Reinigen des Ofens vollständig ausgehängt werden : ziehen, um die Seitengitter aus ihren Sitzen zu entfernen.

FUNKTIONEN

OBER/UNTERHITZE
Zum Garen aller Arten von Gerichten auf nur einer Einschubebene.

HEISSLUFT
Zum Garen verschiedener Speisen, welche die gleiche Gartemperatur auf verschiedenen Einschubebenen (maximal drei) zur gleichen Zeit benötigen. Die Funktion erlaubt das Garen ohne Geschmacksübertragung von einer Speise auf die anderen.

MAXI GAREN
Zum Garen von großen Fleischstücken (über 2,5 kg). Es wird empfohlen, das Fleisch während dem Garvorgang zu wenden, um sicherzustellen, dass beide Seiten gleichmäßig gebräunt werden. Es wird außerdem empfohlen, das Fleischstück gelegentlich zu begießen, um ein übermäßiges Austrocknen zu vermeiden.

PIZZA
Zum Backen verschiedener Sorten und Formen von Brot und Pizza. Es wird empfohlen, die Position der Backbleche nach der Hälfte der Garzeit zu wechseln.

GRILL
Zum Grillen von Steaks, Grillspießen und Bratwürsten, zum Überbacken von Gemüse oder Rösten von Brot. Beim Grillen von Fleisch wird die Verwendung einer Fettpfanne zum Aufsammeln der Garflüssigkeiten empfohlen: Die Fettpfanne unter eine beliebige Einschubebene unter den Rost stellen und 200 ml Trinkwasser zufügen.

GRILL + HEISSLUFT
Zum Garen großer Fleischstücke (Keulen, Roastbeef, Hähnchen). Es wird die Verwendung einer Fettpfanne zum Aufsammeln der Garflüssigkeiten empfohlen: Die Fettpfanne unter eine beliebige Einschubebene unter den Rost stellen und 200 ml Trinkwasser zufügen.

AUFGEHEN LASSEN
Für ein effektives Gären von süßen und salzigen Teigen. Damit die Qualität beim Gehen lassen gesichert ist, die Funktion keinesfalls aktivieren, wenn der Backofen nach einem Garzyklus noch heiß ist.

AUFTAUEN
Zum schnelleren Auftauen von Speisen. Zum Aktivieren der Auftaufunktion drehen Sie den Auswahlknopf auf das Symbol , dann drehen Sie den Thermostatregler im Uhrzeigersinn auf eine beliebige Temperatur. Bei dieser Funktion wird nicht aufgeheizt, so dass jede Temperatur verwendet werden kann. Wenn der Auftauvorgang abgeschlossen ist, drehen Sie die beiden Regler auf die Positionen F und °C.



ECO HEISSLUFT
Zum Garen von Braten und gefüllten Bratenstücken auf einer Einschubebene. Durch eine sanfte, zeitweilige Luftzirkulation wird ein übermäßiges Austrocknen der Speise vermieden. Bei der Verwendung dieser ECO-Funktion bleibt die Beleuchtung während des Garvorgangs ausgeschaltet, aber sie kann durch Drücken der Taste wieder eingeschaltet werden.

BROT AUTO
Diese Funktion wählt automatisch die ideale Temperatur und Backzeit für Brot. Für beste Ergebnisse, das Rezept gut befolgen. Aktivieren Sie die Funktion, wenn der Backofen kalt ist.







GEBÄCK AUTO
Diese Funktion wählt automatisch die ideale Temperatur und Backzeit für Kuchen. Aktivieren Sie die Funktion, wenn der Backofen kalt ist.

ERSTE INBETRIEBNAHME DES GERÄTS

1. EINSTELLUNG DER UHRZEIT

Wenn den Ofen zum ersten Mal eingeschaltet wird, muss die Zeit eingestellt werden:  drücken, bis das Symbol  erscheint und die beiden Ziffern für die Stunden auf dem Display zu blinken beginnen.



Mit  oder  die Stunde einstellen und  zur Bestätigung drücken. Die beiden Ziffern für die Minuten beginnen zu blinken. Mit  oder  die Minuten einstellen und  zur Bestätigung drücken.

Bitte beachten: Wenn das Symbol  blinkt, zum Beispiel nach längerem Stromausfall, müssen Sie die Zeit zurückstellen.

2. AUFWÄRMEN DES OFENS

Ein neuer Ofen kann Gerüche freisetzen, die bei der Herstellung zurückgeblieben sind: Das ist ganz normal.

Vor dem Garen von Speisen wird daher empfohlen, den Ofen in leerem Zustand aufzuheizen, um mögliche Gerüche zu entfernen.

Schutzkarton und Klarsichtfolie aus dem Ofen entfernen und die Zubehörteile entnehmen.

Den Ofen für ungefähr eine Stunde auf 250 °C bevorzugt mit der „Maxi Garen“-Funktion aufheizen. Der Ofen muss während dieser Zeit leer sein. Die Anweisungen zur korrekten Einstellung der Funktion befolgen.

Anmerkungen: Es ist empfehlenswert, den Raum nach dem ersten Gebrauch des Geräts zu lüften.

TÄGLICHER GEBRAUCH

1. AUSWÄHLEN EINER FUNKTION

Um eine Funktion auszuwählen, den *Auswahlknopf* auf das Symbol für die gewünschte Funktion drehen: die Anzeige leuchtet auf und ein Signalton ertönt.



2. EINE FUNKTION AKTIVIEREN

MANUELL

Um die Funktion zu aktivieren, müssen Sie den *Thermostatregler* auf die gewünschte Temperatur drehen.

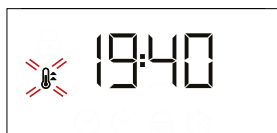

Bitte beachten: Während dem Garen können Sie die Funktion ändern, indem Sie den *Auswahlknopf* drehen oder die Temperatur durch Drehen des *Thermostatreglers* anpassen.

Die Funktion startet nicht, wenn der Thermostatregler auf  steht. Sie können die Garzeit, das Garzeitende (nur wenn eine Garzeit ausgewählt wurde) und einen Timer einstellen.

AUTOMATIK

Um die gewählte Automatikfunktion („Brot“ oder „Backwaren/Torten“) zu starten, den *Thermostatregler* auf den Automatikfunktionen lassen ().

Um das Garen zu beenden, den *Auswahlknopf* auf 0 drehen.

Anmerkungen: Sie können die Garzeit, das Garzeitende und einen Timer einstellen.

AUFGEHEN LASSEN

Zum Aktivieren der Funktion „Aufgehen lassen“, den *Thermostatregler* auf das entsprechende Symbol drehen; Wenn der Ofen auf eine andere Temperatur eingestellt ist, startet die Funktion nicht.

Bitte beachten: Sie können die Garzeit, das Garzeitende (nur wenn eine Garzeit ausgewählt wurde) und einen Timer einstellen.

3. VORHEIZEN

Sobald die Funktion aktiviert ist, geben ein Signalton und ein blinkendes Symbol  auf der Anzeige an, dass das Vorheizen aktiviert wurde.

Nach dieser Phase, ertönt ein akustisches Signal und das feststehende Symbol  auf dem Display zeigen an, dass der Backofen die eingestellte Temperatur erreicht hat: An diesem Punkt die Speise in den Ofen stellen und den Garvorgang fortsetzen.

Anmerkungen: Wird die Speise in den Ofen gestellt, bevor das Vorheizen beendet ist, kann dies negative Auswirkungen auf das endgültige Garergebnis haben.



. PROGRAMMIERTES GAREN

Vor dem Start des programmierten Garen müssen Sie eine Funktion auswählen.



DAUER

 solange drücken, bis das Symbol  und „00:00“ auf der Anzeige blinkt.





 oder  zum Einstellen der gewünschten Garzeit verwenden, anschließend  zur Bestätigung drücken.

Die Funktion durch Drehen des *Thermostatreglers* auf die gewünschte Temperatur aktivieren: Es ertönt ein akustisches Signal und das Display zeigt an, dass der Garvorgang beendet ist.



Hinweise: Um die eingestellte Garzeit zu ändern,  gedrückt halten, bis das Symbol  auf der Anzeige blinkt, dann mit  die Garzeit auf „00:00“ zurückstellen.

Diese Garzeit enthält eine Vorheizphase.

PROGRAMMIERUNG DES GARZEITENDES/ STARTVERZÖGERUNG

Nachdem die Garzeit eingestellt wurde, kann die Aktivierung der Funktion durch die Programmierung der Abschaltzeit verzögert werden:  drücken, bis das Symbol  und die aktuelle Zeit auf der Anzeige blinken.



oder  verwenden  zum Einstellen der Abschaltzeit und  zur Bestätigung drücken.

Die Funktion durch Drehen des *Thermostatreglers* auf die gewünschte Temperatur aktivieren: Die Funktion ist angehalten, bis sie automatisch nach der berechneten Zeit startet, damit der Garvorgang zur eingestellten Zeit endet.



Bitte beachten: Um die Einstellung abubrechen, den *Auswahlknopf* auf **0** drehen, um den Ofen auszuschalten.

Bitte beachten: Die Startvorwahl zum Starten der Funktion ist für Grill- und Turbo Grill-Funktionen nicht verfügbar.

ENDE DES GARVORGANGS

Es ertönt ein akustisches Signal und das Display zeigt an, dass die Funktion beendet ist.

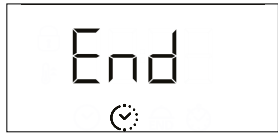



Den *Auswahlknopf* drehen, um eine andere Funktion auszuwählen, oder auf „**0**“ drehen, um den Ofen auszuschalten.



Bitte beachten: Wenn der Timer aktiviert ist, zeigt die Anzeige abwechseln „END“ und die verbleibende Zeit an.

.TIMER EINSTELLEN

Diese Option unterbricht oder programmiert nicht das Garen, aber ermöglicht es Ihnen die Anzeige als Timer zu verwenden, sowohl wenn eine Funktion aktiviert ist als auch bei ausgeschaltetem Ofen.

 solange drücken, bis das Symbol  und „00:00“ auf der Anzeige blinkt.



 oder  zum Einstellen der gewünschten Zeit verwenden und  zur Bestätigung drücken.

Es ertönt ein akustisches Signal, sobald der Timer das Rückzählen der ausgewählten Zeit beendet hat.

Hinweise: Um den Timer abubrechen,  gedrückt halten, bis das Symbol  zu blinken beginnt, dann mit  die Zeit auf „00:00“ zurückstellen.

GARTABELLE

REZEPT	FUNKTION	VORHEIZEN	TEMPERATUR (°C)	DAUER (MIN)	EINSCHUBELENE UND ZUBEHÖRTEILE
Hefekuchen		Ja	160-180	30-90	2/3
		Ja	160 - 180	30 - 90	4 1
Gefüllter Kuchen (Käsekuchen, Strudel, Apfelkuchen)		Ja	160-200	35-90	2
		Ja	160-200	40-90	4 2
Plätzchen (Kekse), Törtchen		Ja	160-180	20-45	3
		Ja	150 - 170	20 - 45	4 2
		Ja	150 - 170	20-45	5 3 1
Beignets		Ja	180 - 210	30-40	3
		Ja	180-200	35-45	4 2
		Ja	180-200	35-45	5 3 1
Baiser		Ja	90	150 - 200	3
		Ja	90	140 - 200	4 2
		Ja	90	140 - 200	5 3 1
Pizza/Brot		Ja	190-250	15-50	1 / 2
		Ja	190-250	20-50	4 2
herkömmliches Brot		-	-	60	2
Tiefkühlpizza		Ja	250	10 - 20	3
		Ja	230 - 250	10 -25	4 2
Herzhafte Kuchen (Gemüse Kuchen, Quiche Lorraine)		Ja	180-200	40-55	3
		Ja	180-200	45 - 60	4 2
		Ja	180-200	45 - 60	5 3 1
Blätterteigtörtchen/salziges Blätterteiggebäck		-	190-200	20-30	3
		-	180-190	20-40	4 2
		-	180-190	20-40	5 3 1

FUNKTIONEN								
	Ober/Unterhitze	Grill	Grill + Heißluft	Pizza	Heißluft	Maxi Garen	Brot Auto	Eco Heißluft
ZUBEHÖRTEILE								
	Rost	Garbehälter oder Backblech auf dem Rost	Fettpfanne / Backblech oder Rost	Fettpfanne	Fettpfanne mit 200 ml Wasser	Backblech		

REZEPT	FUNKTION	VORHEIZEN	TEMPERATUR (°C)	DAUER (MIN)	EINSCHUBEBENE UND ZUBEHÖRTEILE
Lasagne/überbackene Pasta/ Cannelloni /Aufläufe		Ja	190 - 200	45 - 65	2
Lamm/Kalb/ Rind/Schwein 1 kg		Ja	190 - 200	80 - 110	3
Schweinebraten mit Kruste 2 kg		Ja	180-190	110-150	2
Hähnchen/Kaninchen/Ente 1 kg		Ja	200 - 230	50 - 100	2
Puter/Gans 3 kg		-	190-200	100 - 160	2
Fisch ganz, gebacken (Filets, ganz)		Ja	170 - 190	30 - 45	2
Gefülltes Gemüse (Tomaten, Zucchini, Auberginen)		Ja	180-200	50 - 70	2
Getoastetes Brot		-	250	2 - 6	5
Fischfilets/Scheiben		-	230 - 250	20 - 30*	4 3
Bratwürste/Fleischspieße/ Rippchen/Hamburger		-	250	15 - 30*	5 4
Brathähnchen 1-1,3 kg		Ja	200 - 220	55 - 70**	2 1
Roastbeef englisch 1 kg		Ja	200 - 210	35 - 50**	3
Lammkeule, Haxe		Ja	200 - 210	60 - 90**	3
Bratkartoffeln		Ja	200 - 210	35 - 55**	3
Gemüsegratin		-	200 - 210	25 - 55	3
Fleisch und Kartoffeln		Ja	190-200	45 - 100***	4 1
Fisch und Gemüse		Ja	180	30 - 50***	4 1
Lasagne und Fleisch		Ja	200	50 - 100***	4 1
Komplette Mahlzeit: Obsttorte (Einschubebene 5)/ Lasagne (Einschubebene 3)/ Fleisch (Einschubebene 1)		Ja	180-190	40 - 120***	5 3 1
Braten/gefüllte Bratenstücke		-	170 - 180	100 - 150	2

Die angegebene Zeit beinhaltet keine Vorheizphase: es wird empfohlen die Speise erst in den Ofen zu geben und die Garzeit einzustellen, wenn die erforderliche Temperatur erreicht wurde.

* Das Gargut nach halber Garzeit wenden.

** Das Gargut nach zwei Dritteln der Garzeit wenden (bei Bedarf).

*** Voraussichtliche Zeitdauer: Je nach persönlichen Vorlieben können die Speisen zu verschiedenen Zeitpunkten aus dem Ofen genommen werden.

Die Gebrauchsanleitung mit der Tabelle der erprobten Rezepte, die für die Zertifizierungsstellen in Übereinstimmung mit der IEC-Norm 60350-1 zusammengestellt wurden, auf docs.bauknecht.eu runterladen.

FUNKTIONEN								
	Ober/Unterhitze	Grill	Grill + Heißluft	Pizza	Heißluft	Maxi Garen	Brot Auto	Eco Heißluft
ZUBEHÖRTEILE								
	Rost	Garbehälter oder Backblech auf dem Rost	Fettpfanne / Backblech oder Rost	Fettpfanne	Fettpfanne mit 200 ml Wasser	Backblech		

WARTUNG UND REINIGUNG



Für weitere Informationen die Gebrauchsanleitung auf docs.bauknecht.eu runterladen

Verwenden Sie keinen Dampfreiniger.

Bei allen Vorgängen Schutzhandschuhe tragen.

Die gewünschten Vorgänge bei kaltem Ofen durchführen.

Trennen Sie das Gerät von der Stromversorgung.

Keine Stahlwolle, Scheuermittel oder aggressive/ätzende Reinigungsmittel verwenden, da diese die Flächen des Gerätes beschädigen können.

AUSSENFLÄCHEN

- Reinigen Sie die Flächen mit einem feuchten Mikrofasertuch. Sollten sie stark verschmutzt sein, einige Tropfen von pH-neutralen Reinigungsmittel verwenden. Reiben Sie mit einem trockenen Tuch nach.
- Keine aggressiven Reinigungs- oder Scheuermittel verwenden. Falls ein solches Mittel versehentlich mit den Flächen des Geräts in Kontakt kommt, dieses sofort mit einem feuchten Mikrofasertuch reinigen.

INNENFLÄCHEN

- Den Ofen nach jedem Gebrauch abkühlen lassen und anschließend reinigen, vorzugsweise wenn er noch warm ist, um durch Speisereste entstandene Ablagerungen und Flecken zu entfernen. Um die beim Garen von Speisen mit hohem Wassergehalt entstandene Kondensation zu trocknen, den Ofen vollständig abkühlen lassen und anschließend mit einem Tuch oder Schwamm auswaschen.

- Die Tür kann einfach entfernt und wieder angebracht werden für eine einfache Reinigung des Glas. www
- Das Glas der Backofentür mit einem geeigneten Flüssigreinerer reinigen.
- Das obere Heizelement des Grills kann zur Reinigung der oberen Ofenplatte gesenkt werden: Das Heizelement aus seinem Sitz nehmen, dann senken. Um das Heizelement wieder in seine Position zu legen, es anheben, leicht zu sich ziehen und sicherstellen, dass die Halterung sich in ihrem Sitz befindet.

ZUBEHÖRTEILE

Die Zubehörteile nach dem Gebrauch in Geschirrspülmittellauge einweichen, Backofenhandschuhe verwenden, solange die Zubehörteile noch heiß sind. Speiserückstände können dann mit einer Spülbürste oder einem Schwamm entfernt werden.

AUSBAU UND ERNEUTES ANBRINGEN DER TÜR

1. Zur Entfernung der Tür, diese vollständig öffnen und die Haken senken, bis sie sich in entriegelter Position befinden.

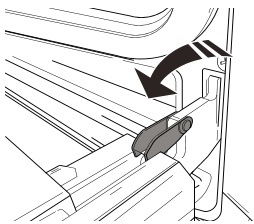

2. Die Tür so weit wie möglich schließen. Die Tür mit beiden Hände festhalten – diese nicht am Griff festhalten. Die Tür einfach entfernen, indem sie weiter geschlossen und gleichzeitig nach oben (a) gezogen wird, bis sie sich aus ihrem Sitz löst (b).

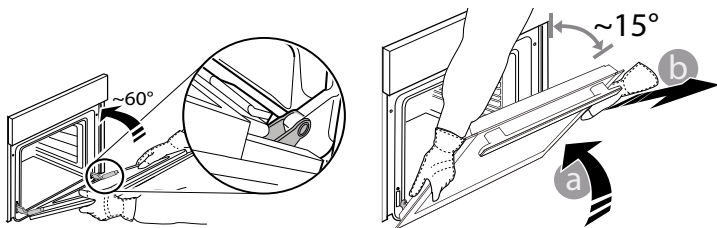

Die Tür seitlich abstellen und auf eine weiche Oberfläche legen.

3. Die Tür erneut anbringen, indem sie zum Ofen geschoben wird und die Haken der Scharniere auf ihre Sitze ausgerichtet werden, den oberen Teil auf seinem Sitz sichern.

4. Die Tür senken und anschließend vollständig öffnen. Die Haken in ihre Ausgangsposition senken: Sicherstellen, dass die Haken vollständig gesenkt werden.

5. Versuchen, die Tür zu schließen und sicherstellen, dass sie auf das Bedienfeld ausgerichtet ist. Ist dies nicht der Fall, die oben aufgeführten Schritte wiederholen.

ZUM REINIGEN AUF - GLASREINIGUNG KLICKEN

1. Nach dem Ausbau der Tür diese auf einer weichen Fläche mit dem Griff nach unten abgelegt, gleichzeitig die zwei Halteklammern drücken und die obere Kante der Tür zu sich ziehen und entfernen.

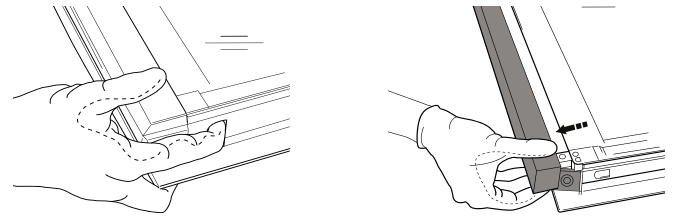

2. Das Innenglas mit beiden Händen anheben und fest halten, es entfernen und auf eine weiche Fläche legen, um es daraufhin zu reinigen.

3. Um das Innenglas wieder richtig einzusetzen, sicherstellen, dass das „R“ in der linken Ecke sichtbar ist und die klare (nicht aufgedruckte) Oberfläche nach oben zeigt. Zuerst die lange Seite des Glas, die mit einem „R“ gekennzeichnet ist in die Halterungen einsetzen, dann in die Position absenken.

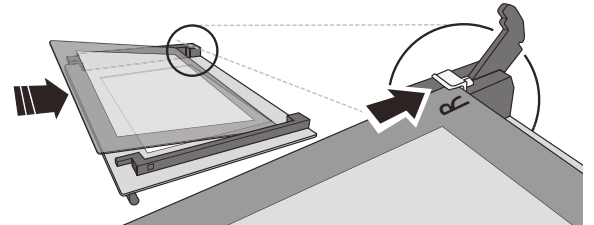

4. Die obere Ecke wieder anbringen: ein Klick bestätigt die richtige Positionierung. Sicherstellen, dass die Dichtung vor Wiedereinbau der Tür befestigt wird.

Problem	Mögliche Ursache	Abhilfemaßnahme
Der Backofen funktioniert nicht	Stromausfall. Trennung von der Stromversorgung	Überprüfen, ob das Stromnetz Strom führt und der Backofen an das Netz angeschlossen ist. Den Backofen aus- und wieder einschalten, um festzustellen, ob die Störung erneut auftritt
Das Display zeigt ein „F“ gefolgt von einer Nummer an	Softwareproblem	Den nächsten Kundendienst kontaktieren und den Buchstaben oder die Nummer nach dem Buchstaben „F“ angeben

HILFREICHE TIPPS



Für weitere Informationen die Gebrauchsanleitung auf docs.bauknecht.eu runterladen

LESEN DER GARTABELLE

Die Tabelle listet die besten Funktionen, Zubehörteile und Einschubebenen auf, die für die verschiedenen Arten von Speisen zu verwenden sind. Die Garzeiten gelten ab dem Moment, in dem Sie das Gargut in den Ofen geben wird, die (eventuell erforderliche) Vorheizzeit zählt nicht dazu. Die Gartemperaturen und -zeiten sind nur Richtwerte und sind von der Menge des Garguts und von den verwendeten Zubehörteilen abhängig. Zunächst die niedrigeren Einstellungen verwenden und, falls das erzielte Garergebnis nicht den Wünschen entspricht, zu den höheren Einstellungen übergehen. Es wird empfohlen, die mitgelieferten Zubehörteile und vorzugsweise Kuchenformen und Backbleche aus dunklem Metall zu verwenden. Es können auch Töpfe und Zubehörteile aus feuerfestem Glas oder Keramik verwendet werden, aber es ist zu berücksichtigen, dass sich die Garzeiten dadurch etwas verlängern.

GLEICHZEITIGES GAREN VERSCHIEDENER SPEISEN

Bei der Verwendung der Funktion „Heißluft“ lassen sich verschiedene Speisen, welche die gleiche Gartemperatur erfordern (z. B.: Fisch und Gemüse) auf verschiedenen Einschubebenen gleichzeitig garen. Die Speise mit kürzerer Garzeit aus dem Ofen nehmen und die Speisen mit längerer Garzeit weiterhin im Ofen lassen.

TECHNISCHE DATEN

Die technischen Daten mit Angabe der Energiedaten für dieses Gerät können auf der Internetseite docs.bauknecht.eu runtergeladen werden

WIE IST DIE GEBRAUCHSANLEITUNG ERHÄLTICH

> Die Gebrauchsanleitung von unserer Internetseite docs.bauknecht.eu runterladen (es kann der QR-Code verwendet werden), dabei den Produkthandelscode angeben.



> Alternativ unseren Kundendienst kontaktieren

BROT AUTO FUNKTION

Für beste Ergebnisse, die Anweisungen genau befolgen und das Rezept zum Mischen von 1000 g Teig verwenden: 600 g Mehl, 360 g Wasser, 11 g Salz, 25 g Frischhefe (oder zwei Päckchen Trockenhefe).

Zum optimalen Aufgehen, 90 Minuten bei Raumtemperatur oder 60 Minuten im Ofen mit der Funktion „Gehen lassen“ stehen lassen.

Den Teig in den (kalten) Ofen geben, 100 cm³ kaltes Trinkwasser auf den Ofenboden geben und die „Brot Auto“-Funktion aktivieren. Nach dem Garen, den Teig auf dem Rost stehen lassen, bis er vollständig abgekühlt ist.

UNSEREN KUNDENDIENST KONTAKTIEREN

Unsere Kontaktdaten sind im Garantiehandbuch zu finden. Wird der Kundendienst kontaktiert, bitte die Codes auf dem Typenschild des Produkts angeben.

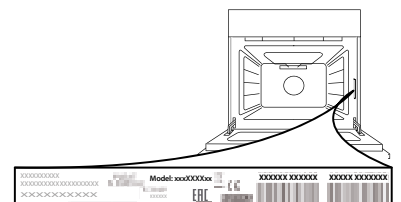

GUIDE D'UTILISATION QUOTIDIENNE



MERCI D'AVOIR ACHETÉ UN PRODUIT BAUKNECHT

Afin de recevoir un service et un support complet, merci d'enregistrer votre appareil sur www.bauknecht.eu/register



Vous pouvez télécharger les Consignes de sécurité et le Guide d'utilisation et d'entretien en visitant notre site Web docs.bauknecht.eu et en suivant les consignes au dos de ce livret.

! Lire attentivement les Consignes de santé et de sécurité avant d'utiliser l'appareil.

DESCRIPTION DU PRODUIT

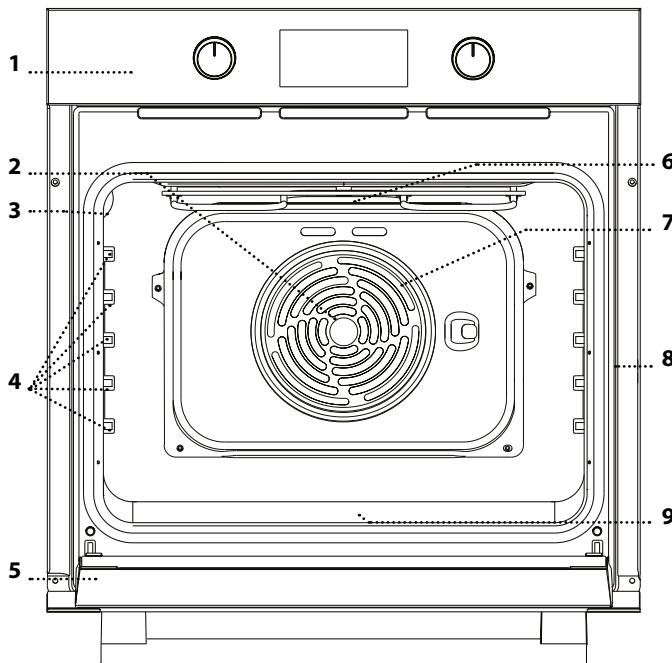

1. Bandeau de commande
2. Ventilateur
3. Lampe
4. Supports de grille
(Le niveau est indiqué à l'avant du four)
5. Porte
6. Élément chauffant supérieur/gril
7. Élément chauffant rond (invisible)
8. Plaque signalétique
(ne pas enlever)
9. Élément chauffant inférieur
(invisible)

PANNEAU DE COMMANDES

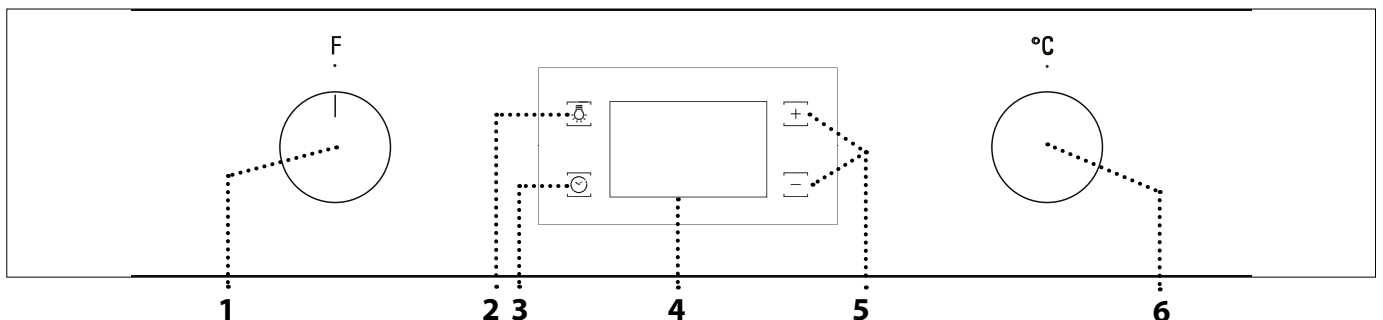

1. BOUTON DE SÉLECTION

Pour allumer le four en sélectionnant une fonction. Tournez à la position 0 pour éteindre le four.

2. ÉCLAIRAGE

Avec le four allumé, appuyez pour allumer ou éteindre l'ampoule du compartiment du four.

3. RÉGLAGE DE L'HEURE

Pour accéder les réglages pour le temps de cuisson, le départ différé, et la minuterie. Pour afficher l'heure lorsque le four est éteint.

4. ÉCRAN

5. BOUTONS DE RÉGLAGES

Pour changer les réglages du temps de cuisson.

6. BOUTON THERMOSTAT

Tournez pour sélectionner la température désirée lorsque vous utilisez les fonctions manuelles. Fonctions automatiques 0.

Veillez noter : Tous les boutons sont de type bouton-poussoir. Appuyez au centre du bouton pour le sortir de son logement.

GRILLE MÉTALLIQUE

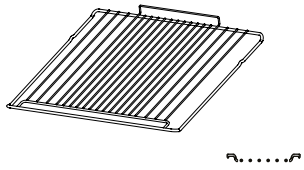

LÈCHEFRITE

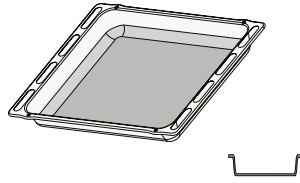

PLAQUE DE CUISSON

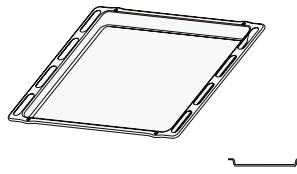

Le nombre d'accessoires peut varier en fonction du modèle acheté. Il est possible d'acheter séparément d'autres accessoires auprès du Service Après-Vente.

INSÉRER LA GRILLE MÉTALLIQUE ET LES AUTRES ACCESSOIRES

• Insérez la grille métallique au niveau désiré en la tenant légèrement inclinée vers le haut et en déposant la partie surélevée arrière (pointant vers le haut) en premier. Glissez-la ensuite horizontalement sur le support de grille aussi loin que possible.

• Les autres accessoires, comme la lèchefrite et la plaque de cuisson, sont introduits horizontalement en les glissant le long des supports de grille.
• Les supports de grille peuvent être enlevés pour faciliter le nettoyage du four : tirez pour les enlever de leurs appuis.

FONCTIONS

CONVECTION NATURELLE
Pour cuire tout type de plat sur une seule grille.

CHALEUR PULSÉE
Pour cuire différents aliments demandant la même température de cuisson sur plusieurs grilles (maximum de trois) en même temps. Cette fonction permet de cuire différents aliments sans transmettre les odeurs d'un aliment à l'autre.

CUISSON GROSSE PIÈCE
Pour cuire de gros morceaux de viande (supérieurs à 2,5 kg). Nous vous conseillons de retourner la viande durant la cuisson pour s'assurer que les deux côtés brunissent de façon égale. Nous vous conseillons d'arroser le rôti de temps en temps pour éviter qu'il ne s'assèche.

PIZZA
Pour cuire différents types et tailles de pain et de pizza. Nous vous conseillons d'échanger la position des plaques de cuisson à la mi-cuisson.

GRIL
Pour cuire des biftecks, des brochettes, et des saucisses, faire gratiner des légumes et griller du pain. Pour la cuisson de la viande, nous vous conseillons d'utiliser une lèchefrite pour recueillir les jus de cuisson : Placez la lèchefrite, contenant 200 ml d'eau, sur n'importe quel niveau sous la grille métallique.

TURBO GRIL
Pour griller de gros morceaux de viande (gigots, rôti, poulets). Nous vous conseillons d'utiliser une lèchefrite pour recueillir les jus de cuisson : Placez la lèchefrite, contenant 200 ml d'eau, sur n'importe quel niveau sous la grille métallique.

LEVAGE DE LA PÂTE
Pour obtenir une meilleure fermentation des pâtes sucrées ou salées. Pour assurer la qualité de levage, n'activez pas la fonction si le four est encore chaud après un cycle de cuisson.

DÉCONGÉLATION
Pour décongeler les aliments plus rapidement. Pour activer la fonction de décongélation, tournez le bouton de sélection sur l'icône puis tournez le bouton du thermostat dans le sens des aiguilles d'une montre jusqu'à n'importe quelle température. Cette fonction ne chauffe pas, de sorte que n'importe quelle température peut être utilisée. Lorsque la décongélation est terminée, tournez les deux commandes sur les positions F et °C.



ÉCO CHALEUR PULSÉE
Pour cuire les rôtis farcis et les rôtis sur une seule grille. Les aliments ne s'assèchent pas trop grâce à une légère circulation d'air intermittente. Lorsque vous utilisez la fonction ÉCO, le voyant reste éteint durant la cuisson, mais peut être rallumé temporairement en appuyant sur .

A PAIN AUTO
Cette fonction sélectionne automatiquement la meilleure température et le meilleur temps de cuisson pour le pain. Pour les meilleurs résultats, suivez minutieusement la recette. Activez la fonction lorsque le four est froid.







A PÂTISSERIES AUTO
Cette fonction sélectionne automatiquement la meilleure température et le meilleur temps de cuisson pour les gâteaux. Activez la fonction lorsque le four est froid.

UTILISER L'APPAREIL POUR LA PREMIÈRE FOIS

1. RÉGLAGE DE L'HEURE

Vous devez régler l'heure lorsque vous allumez l'appareil pour la première fois : Appuyez sur  jusqu'à ce que le voyant  et les deux chiffres indiquant l'heure clignotent à l'écran.



Utilisez  ou  pour régler l'heure et appuyez sur  pour confirmer. Les deux chiffres des minutes clignotent. Utilisez  ou  pour régler les minutes et appuyez sur  pour confirmer.

Veillez noter: Lorsque le voyant  clignote (par exemple après des pannes de courant prolongées), vous devrez régler l'heure de nouveau.

2. RÉCHAUFFER LE FOUR

Un nouveau four peut dégager des odeurs provenant de la fabrication : ceci est parfaitement normal. Avant de cuire des aliments, nous vous conseillons de chauffer le four à vide pour éliminer les odeurs.

Enlevez les cartons de protection ou les pellicules transparentes du four, et enlevez les accessoires qui se trouvent à l'intérieur.

Chauffez le four à 250 °C pour environ une heure en utilisant la fonction « Cuisson Grosse pièce ». Le four doit être vide durant cette opération. Suivez les directives pour régler correctement la fonction.

Veillez noter: Nous vous conseillons d'aérer la pièce après avoir utilisé l'appareil pour la première fois.

UTILISATION QUOTIDIENNE

1. SÉLECTIONNER UNE FONCTION

Pour sélectionner une fonction, tournez le *bouton de sélection* sur le symbole de la fonction désirée : l'écran s'illumine et un signal sonore se fait entendre.



2. ACTIVER UNE FONCTION

MANUEL

Pour lancer la fonction que vous avez sélectionnée, tournez le *bouton du thermostat* pour régler la température requise.

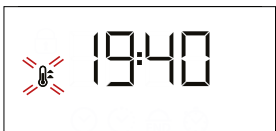

Veillez noter : Lors de la cuisson, vous pouvez changer la fonction en tournant le *bouton de sélection* ou ajuster la température en tournant le *bouton du thermostat*.

La fonction ne démarre pas tant que le bouton du thermostat est sur . Vous pouvez régler le temps de cuisson, le temps de fin de cuisson (seulement si vous réglez le temps de cuisson) et la minuterie.

AUTOMATIQUE

Pour lancer la fonction automatique que vous avez sélectionnée (« Pain » ou « Gâteaux »), gardez le *bouton du thermostat* à la position pour les fonctions automatiques ().

Pour terminer la cuisson, tournez le *bouton de sélection* à la position 0.

Veillez noter : Vous pouvez régler le temps de fin de cuisson et la minuterie.

LEVAGE DE LA PÂTE

Pour lancer la fonction « Levage de la pâte », tournez le *bouton thermostat* au symbole correspondant; si le four est réglé à une température différente, la fonction de démarrera pas.

Veillez noter : Vous pouvez régler le temps de cuisson, le temps de fin de cuisson (seulement si vous réglez le temps de cuisson) et la minuterie.

3. PRÉCHAUFFAGE

Une fois que la fonction est lancée, un signal sonore et un voyant  qui clignote à l'écran confirmant que la phase de préchauffage est activée.



À la fin de cette phase, un signal sonore et un voyant stable  indique que le four a atteint la température désirée : vous pouvez maintenant placer les aliments à l'intérieur et débiter la cuisson.

Veillez noter: Placer les aliments dans le four avant que le préchauffage soit terminé peut affecter la cuisson.



. PROGRAMMER LA CUISSON

Vous devez sélectionner une fonction avant de pouvoir lancer un programme de cuisson.



DURÉE

Appuyez sur la touche  jusqu'à ce que le voyant  et « 00:00 » clignotent à l'écran.



Utilisez  ou  pour régler la durée de cuisson et appuyez sur  pour confirmer.



Lancez la fonction en tournant le *bouton du thermostat* à la température désirée : un signal sonore se fait entendre et l'écran s'illumine lorsque la cuisson est terminée.

Remarques : Pour annuler le temps de cuisson, appuyez sur  jusqu'à ce que le voyant  clignote sur l'écran, utilisez ensuite  pour remettre le temps de cuisson à « 00:00 ».



».

Le temps de cuisson inclut la phase de préchauffage.

PROGRAMMER L'HEURE DE FIN DE CUISSON/ DÉPART DIFFÉRÉ

Après avoir réglé le temps de cuisson, vous pouvez retarder le début de la fonction en programmant le temps de fin de cuisson : appuyez sur  jusqu'à ce que l'icône  et l'heure actuelle clignotent à l'écran.



Utilisez  ou  pour régler la durée de cuisson et appuyez sur  pour confirmer.

Lancez la fonction en tournant le *bouton du thermostat* à la température désirée : la fonction reste en veille et démarre automatiquement après la période d'attente calculée pour que la cuisson se termine à l'heure désirée.



Veuillez noter : Pour annuler le réglage, éteindre le four en tournant le *bouton de sélection* à la position « 0 ».

Remarques : Le démarrage différé de la fonctionnalité n'est pas disponible pour les fonctions Grill et Turbo-grill.

FIN DE CUISSON

Un signal sonore se fait entendre et l'écran s'illumine pour indiquer que la fonction est terminée.

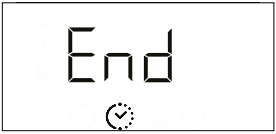



Tournez le *bouton de sélection* pour sélectionner une différente fonction ou le placer à la position « 0 » pour éteindre le four.



Veuillez noter: Si la minuterie fonctionne, l'écran affiche « END » en alternance avec le temps restant.

. RÉGLER LA MINUTERIE

Cette option n'interrompt pas ou ne programme pas la cuisson, mais permet d'utiliser l'écran comme minuterie, durant le fonctionnement d'une fonction ou quand le four est éteint.

Appuyez sur la touche  jusqu'à ce que le voyant  et « 00:00 » clignotent à l'écran.



Utilisez  ou  pour régler l'heure désirée et appuyez sur  pour confirmer.

Un signal sonore se fait entendre lorsque la minuterie a terminé le compte à rebours.

Remarques : Pour annuler la minuterie, appuyez sur  jusqu'à ce que le voyant  clignote, utilisez ensuite  pour remettre le temps à « 00:00 ».

TABLEAU DE CUISSON

RECETTE	FONCTION	PRECHAUFFER	TEMPÉRATURE (°C)	DURÉE (MIN)	NIVEAU ET ACCESSOIRES
Gâteaux à pâte levée		Oui	160-180	30-90	2/3
		Oui	160 - 180	30 - 90	4 1
Gâteau fourré (gâteau au fromage, strudel, tarte aux fruits)		Oui	160 - 200	35-90	2
		Oui	160 - 200	40 - 90	4 2
Biscuits/tartelettes		Oui	160-180	20-45	3
		Oui	150 - 170	20 - 45	4 2
		Oui	150 - 170	20-45	5 3 1
Choux ronds		Oui	180 - 210	30-40	3
		Oui	180-200	35-45	4 2
		Oui	180-200	35-45	5 3 1
Meringues		Oui	90	150 - 200	3
		Oui	90	140 - 200	4 2
		Oui	90	140 - 200	5 3 1
Pizza/pain		Oui	190-250	15-50	1 / 2
		Oui	190-250	20-50	4 2
Pain		-	-	60	2
Pizza congelée		Oui	250	10 - 20	3
		Oui	230 - 250	10 -25	4 2
Pâtisseries salées (tarte aux légumes, quiche)		Oui	180-200	40-55	3
		Oui	180-200	45 - 60	4 2
		Oui	180-200	45 - 60	5 3 1
Vol-au-vent/biscuits à pâte feuilletée		-	190-200	20 - 30	3
		-	180-190	20-40	4 2
		-	180-190	20-40	5 3 1

FONCTIONS								
	Convection naturelle	Gril	Turbo Gril	Pizza	Chaleur pulsée	Cuisson grosse pièce	Pain Auto	Éco Chaleur pulsée
ACCESSOIRES								
	Grille métallique	Casserole ou plaque de cuisson sur la grille	Lèche-frite/plaque de cuisson sur grille métallique	LÈCHEFRITE	Lèche-frite contenant 200 ml d'eau	Plaque de cuisson		

RECETTE	FONCTION	PRECHAUFFER	TEMPÉRATURE (°C)	DURÉE (MIN)	NIVEAU ET ACCESSOIRES
Lasagnes / Pâtes cuites / Cannelloni / Tartes		Oui	190 - 200	45 - 65	2
Agneau/veau/ bœuf/porc 1 kg		Oui	190 - 200	80 - 110	3
Rôti de porc avec grattons 2 kg		Oui	180-190	110-150	2
Poulet/lapin/canard 1 kg		Oui	200 - 230	50 - 100	2
Dinde/oie 3 kg		-	190-200	100 - 160	2
Poisson au four (darne, entier)		Oui	170 - 190	30 - 45	2
Légumes farcis (tomates, courgettes, aubergines)		Oui	180-200	50 - 70	2
Pain grillé		-	250	2 - 6	5
Filets/tranches de poisson		-	230 - 250	20 - 30*	4 3
Saucisses/brochettes/côtes levées/ hamburgers		-	250	15 - 30*	5 4
Poulet rôti 1 - 1,3 kg		Oui	200 - 220	55 - 70**	2 1
Rosbif saignant 1 kg		Oui	200 - 210	35 - 50**	3
Gigot d'agneau/jarret		Oui	200 - 210	60 - 90**	3
Pom. terre rôties		Oui	200 - 210	35 - 55**	3
Gratin de légumes		-	200 - 210	25 - 55	3
Viande et pommes de terre		Oui	190-200	45 - 100***	4 1
Poisson et légumes		Oui	180	30 - 50***	4 1
Lasagnes & viande		Oui	200	50 - 100***	4 1
Repas complet : tarte aux fruits (niveau 5)/ lasagne (niveau 3)/ viande (niveau 1)		Oui	180-190	40 - 120***	5 3 1
Rôtis/rôtis farcis		-	170 - 180	100 - 150	2

La durée de cuisson ne comprend pas la phase de préchauffage : Nous vous conseillons de placer les aliments dans le four et régler le temps de cuisson seulement après avoir atteint la température désirée.

* Tourner les aliments à mi-cuisson.

** Au besoin, retournez les aliments aux deux tiers de la cuisson.

*** Temps approximatif : les plats peuvent être retirés en tout temps, selon vos préférences personnelles.

Téléchargez le Guide d'utilisation et entretien sur docs.bauknecht.eu pour le tableau de recettes éprouvées, compilé pour les autorités de certification, conformément aux normes CEI et CEI 60350-1.

FONCTIONS								
ACCESSOIRES								

NETTOYAGE ET ENTRETIEN



Pour plus d'information, téléchargez le Guide d'utilisation et d'entretien sur docs.bauknecht.eu

N'utilisez pas d'appareil de nettoyage à vapeur.

Utilisez des gants de protection lors des opérations.

Effectuez les opérations nécessaires lorsque le four est froid.

Débranchez l'appareil de l'alimentation électrique.

N'utilisez pas de laine d'acier, de tampons à récurer abrasifs, ou des détergents abrasifs ou corrosifs, ils pourraient endommager les surfaces de l'appareil.

SURFACES EXTÉRIEURES

- Nettoyez les surfaces à l'aide d'un chiffon en microfibre humide. Si elles sont très sales, ajoutez quelques gouttes de détergent à pH neutre. Essuyez avec un chiffon sec.
- N'utilisez pas de détergents corrosifs ou abrasifs. Si l'un de ces produits entre en contact avec des surfaces de l'appareil, nettoyez immédiatement à l'aide d'un chiffon en microfibre humide.

SURFACES INTÉRIEURES

- Après chaque utilisation, laissez le four refroidir et ensuite nettoyez-le, de préférence lorsqu'il est encore tiède, pour enlever les dépôts ou taches laissés par les résidus de nourriture. Pour essuyer la condensation qui s'est formée à la suite de la cuisson d'aliments à haute teneur en eau, laissez le four refroidir complètement, et essuyez-le ensuite avec un linge ou une éponge.

- La porte peut facilement être enlevée et remplacée pour faciliter le nettoyage de la vitre. 
- Nettoyez le verre dans la porte avec un détergent liquide approprié.
- L'élément chauffant supérieur du gril peut être baissé pour nettoyer la paroi supérieure du four : Retirez l'élément chauffant de son appui, ensuite abaissez-le. Pour replacer l'élément chauffant, soulevez-le, tirez légèrement vers l'avant, et assurez-vous que l'onglet de soutien est dans son appui.

ACCESSOIRES

Faites tremper les accessoires dans de l'eau contenant un détergent à vaisselle, utilisez des gants de cuisine s'ils sont encore chauds. Utilisez une brosse à vaisselle ou une éponge pour enlever les résidus d'aliments.

ENLEVER ET RÉINSTALLER LA PORTE

1. Pour enlever la porte, ouvrez-la complètement et abaissez les loquets jusqu'à ce qu'ils soient déverrouillés.

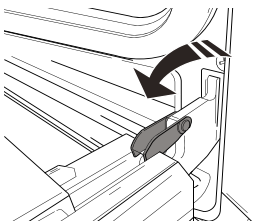

2. Fermez le plus possible la porte. Tenez la porte fermement avec les deux mains – ne la tenez pas par la poignée. Enlevez simplement la porte en continuant à la fermer tout en la tirant vers le haut (a) jusqu'à ce qu'elle soit dégagée de ses appuis (b).

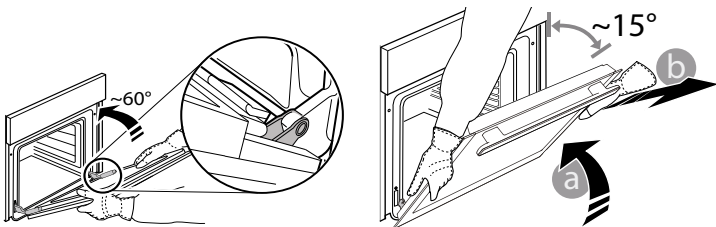

Placez la porte de côté, l'appuyant sur une surface souple.

3. Réinstallez la porte en la plaçant devant le four pour aligner les crochets des charnières avec leurs appuis, et insérez la partie supérieure sur son appui.

4. Abaissez la porte pour ensuite l'ouvrir complètement. Abaissez les loquets dans leur position originale : assurez-vous de les abaisser complètement.

5. Essayez de fermer la porte et assurez-vous qu'elle est alignée avec le panneau de commande. Sinon, répétez les étapes précédentes.

CLICK&CLEAN - NETTOYER LA VITRE

1. Après avoir enlevé la porte et l'avoir placée sur une surface matelassée, les poignées vers le bas, appuyez sur les deux fermetures en même temps et enlevez le bord supérieur de la porte en la tirant vers vous.

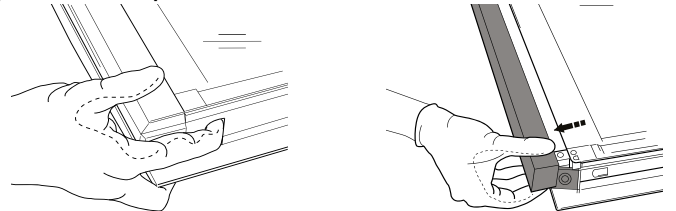

2. Soulevez et tenez fermement la vitre intérieure avec les deux mains, enlevez-la et placez-la sur une surface matelassée avant de la nettoyer.

3. Pour bien replacer la vitre intérieure, assurez-vous que le « R » est visible dans le coin gauche et que la surface claire (pas d'imprimée) est placée vers le haut. En premier, insérez la longue partie de la vitre marquée d'un « R » dans les appuis des guides, abaissez-la ensuite en place.

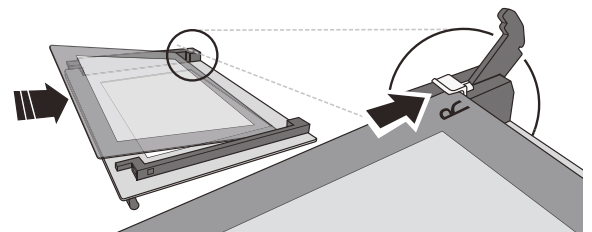

4. Remplacez le bord supérieur : un déclic indique le positionnement correct. Assurez-vous que le joint est bien placé avant de replacer la porte.

Problème	Cause probable	Solution
Le four ne fonctionne pas	Coupure de courant. Débranchez de l'alimentation principale	Assurez-vous qu'il n'y a pas de panne de courant et que le four est bien branché. Éteignez puis rallumez le four pour voir si le problème persiste
L'écran affiche la lettre « F » suivi d'un numéro	Problème de logiciel	Prenez en note la lettre ou le numéro qui suit la lettre « F » et contactez le Service Après-vente le plus près

CONSEILS UTILES



Pour plus d'information, téléchargez le Guide d'utilisation et d'entretien sur docs.bauknecht.eu

COMMENT LIRE LE TABLEAU DE CUISSON

Le tableau indique la meilleure fonction, les accessoires, et le niveau à utiliser pour la cuisson des différents types d'aliments. Les temps de cuisson commencent au moment de l'introduction du plat dans le four et ne tiennent pas compte du préchauffage (s'il est nécessaire). Les températures et temps de cuisson sont approximatifs et dépendent de la quantité d'aliments et du type d'accessoire. Pour commencer, utilisez les valeurs conseillées les plus basses, et si les aliments ne sont pas assez cuits, augmentez-les. Utilisez les accessoires fournis, et de préférence des moules à gâteau en métal foncés et des plats de cuisson. Vous pouvez aussi utiliser des plaques et accessoires en pyrex ou en céramique ; cependant, les temps de cuisson seront sensiblement plus longs.

FONCTION PAIN AUTO

Pour les meilleurs résultats, suivez minutieusement les consignes en utilisant la recette pour mélanger 1000 g de pâte : 600 g de farine, 360 g d'eau, 11 g de sel, 25 g de levure fraîche (ou deux paquets de levure en poudre).

Pour la meilleure fermentation, laissez environ 90 minutes à la température de la pièce ou 60 minutes dans le four en utilisant la fonction « Levage ».

Placez la pâte dans le four froid, versez 100 cc d'eau potable froide dans le fond du four et lancez la fonction « Pain Auto ». Après la cuisson, laissez la pâte sur la grille métallique jusqu'à ce qu'elle soit complètement refroidie.

CUIRE DES ALIMENTS DIFFÉRENTS EN MÊME TEMPS

La fonction « Chaleur pulsée » permet de cuire simultanément plusieurs aliments nécessitant la même température de cuisson (par exemple : poisson et légumes), sur différentes grilles. Enlevez les aliments qui demandent moins de cuisson et laissez dans le four les aliments qui ont besoin de plus de cuisson.

FICHE TECHNIQUE

La fiche technique de l'appareil, incluant les taux d'efficacité énergétique, peuvent être téléchargées sur notre site Web docs.bauknecht.eu

COMMENT OBTENIR LE GUIDE D'UTILISATION ET ENTRETIEN

> Téléchargez le Guide d'utilisation et d'entretien sur notre site Web docs.bauknecht.eu (vous pouvez utiliser ce code QR), en précisant le code commercial du produit.



> Une autre façon est de contacter notre Service Après-vente

CONTACTER LE SERVICE APRÈS-VENTE

Vous pouvez trouver comment nous contacter dans le livret de garantie. Lorsque vous contactez notre Service Après-vente, veuillez indiquer les codes disponibles sur la plaque signalétique de l'appareil.

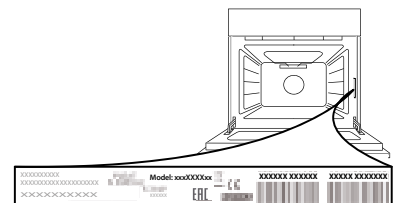

GUIDA RAPIDA



GRAZIE PER AVERE ACQUISTATO UN PRODOTTO BAUKNECHT

Per ricevere un'assistenza più completa, registrare il prodotto su www.bauknecht.eu/register



Scaricare le istruzioni per la sicurezza e le istruzioni per l'uso collegandosi al sito docs.bauknecht.eu e seguire la procedura indicata sul retro.



Leggere attentamente le istruzioni per la sicurezza prima di utilizzare il prodotto.

DESCRIZIONE PRODOTTO

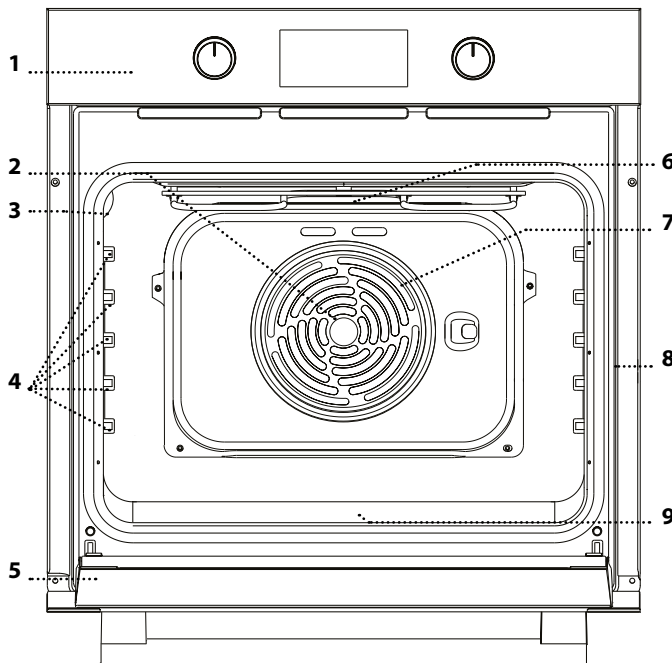

1. Pannello di controllo
2. Ventola
3. Lampada
4. Griglie laterali
(il livello è indicato sulla parete della cavità)
5. Porta
6. Resistenza superiore / grill
7. Resistenza circolare
(non visibile)
8. Targhetta matricola
(da non rimuovere)
9. Resistenza inferiore
(non visibile)

PANNELLO DI CONTROLLO

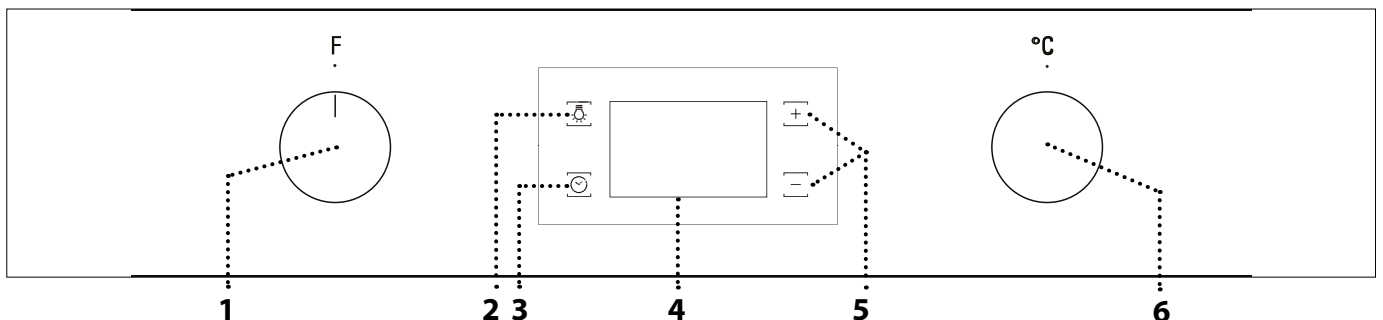

1. MANOPOLA DI SELEZIONE

Per accendere il forno selezionando una funzione. Per spegnere il forno, ruotare sulla posizione 0.

2. LUCE

A forno acceso, premere per accendere o spegnere la luce di cavità del forno.

3. IMPOSTAZIONE DEL TEMPO

Per accedere alle impostazioni della durata di cottura, dell'avvio ritardato e del timer. A forno spento, per visualizzare l'ora.

4. DISPLAY

5. TASTI DI REGOLAZIONE

Per modificare le impostazioni di durata.

6. MANOPOLA TERMOSTATO

Ruotare per selezionare la temperatura desiderata attivando le funzioni manuali. Uso delle funzioni automatiche **0**.

Note: le manopole sono a scomparsa; premere al centro delle stesse per estrarle dalla loro sede.

GRIGLIA

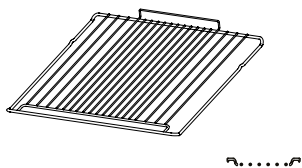

LECCARDA

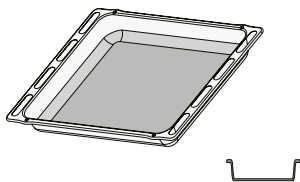

TEGLIA

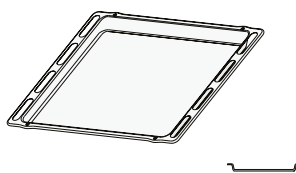

Il numero di accessori può variare a seconda del modello acquistato. È possibile acquistare separatamente altri accessori presso il Servizio Assistenza Clienti.

INSERIMENTO DELLA GRIGLIA E DEGLI ALTRI ACCESSORI

• Inserire la griglia tenendola leggermente inclinata verso l'alto, appoggiando dapprima il lato posteriore rialzato - orientato verso l'alto - sul livello desiderato. Quindi, farla scivolare orizzontalmente sulla griglia laterale fino a fine corsa.

• Gli altri accessori, come leccarda o piastra dolci, si inseriscono orizzontalmente facendoli scivolare sulle griglie laterali.
• Per facilitare la pulizia del forno è possibile rimuovere le guide laterali, tirandole in modo da estrarle dalle sedi.

FUNZIONI

STATICO

Per cuocere qualsiasi tipo di pietanza su un solo ripiano.

TERMOVENTILATO

Per cuocere contemporaneamente su più ripiani (massimo tre) alimenti, anche diversi, che richiedono medesima temperatura di cottura. La funzione permette di cuocere senza trasmissione di odori da un alimento all'altro.

MAXI COOKING

Per cuocere carni di grosse dimensioni (superiori ai 2,5 kg). Si raccomanda di girare la carne durante la cottura per farla rosolare su tutti i lati. Si consiglia inoltre di irrorare la carne di tanto in tanto per evitare che asciughi eccessivamente.

PIZZA

Per cuocere diversi tipi e formati di pizza e focaccia. Si consiglia di invertire la posizione delle teglie a metà cottura.

GRILL

Per grigliare costate, spiedini e salsicce, gratinare verdure o dorare il pane. Per la grigliatura delle carni, si consiglia di utilizzare una leccarda per raccogliere il liquido di cottura: posizionarla un livello sotto la griglia e aggiungere 200 ml di acqua potabile.

TURBO GRILL

Per arrostiti grossi pezzi di carne (cosciotti, roast beef, polli). Si consiglia di utilizzare una leccarda per raccogliere il liquido di cottura: posizionarla un livello sotto la griglia e aggiungere 200 ml di acqua potabile.

LIEVITAZIONE

Per ottenere una lievitazione ottimale di impasti dolci o salati. Per preservare la qualità della lievitazione, non attivare la funzione se il forno è ancora caldo dopo un ciclo di cottura.

SCONGELAMENTO

Per velocizzare lo scongelamento degli alimenti. Per attivare la funzione di scongelamento, ruotare la manopola di selezione sull'icona , quindi ruotare la manopola del termostato in senso orario su qualsiasi temperatura. Questa funzione non riscalda, quindi può essere utilizzata qualsiasi temperatura. Quando lo scongelamento è terminato, ruotare i due comandi nelle posizioni F e °C.

ECO TERMOVENTILATO

Per cuocere arrostiti e arrostiti ripieni su uno stesso ripiano. La circolazione intermittente dell'aria impedisce un'eccessiva asciugatura degli alimenti. In questa funzione ECO la luce rimane spenta durante la cottura e può essere riaccesa premendo .

^A PANE AUTO



Questa funzione seleziona automaticamente temperatura e tempo ideali per la cottura del pane. Per ottenere i migliori risultati seguire attentamente la ricetta. Attivare la funzione a forno freddo.

^A DOLCI AUTO







Questa funzione seleziona automaticamente temperatura e tempo ideali per la cottura dei dolci. Attivare la funzione a forno freddo.

PRIMO UTILIZZO

1. IMPOSTARE L'ORA

Alla prima accensione, è necessario impostare l'ora: premere  fino a che sul display non lampeggiano l'icona  e le due cifre relative all'ora.



Utilizzare  o  per impostare l'ora e premere  per confermare. Sul display lampeggiano le due cifre relative ai minuti: utilizzare  o  per impostare l'ora e premere  per confermare.

Note: quando l'icona  lampeggia, ad esempio dopo una prolungata interruzione di corrente, è necessario impostare l'ora.

2. RISCALDARE IL FORNO

Un nuovo forno può rilasciare degli odori dovuti alla lavorazione di fabbrica: questo è normale. Prima di cucinare gli alimenti è dunque raccomandato di riscaldare a vuoto il forno per rimuovere ogni odore.

Rimuovere protezioni di cartone o pellicole trasparenti e togliere gli accessori dal forno.

Scaldare il forno a 250 °C per circa un'ora, utilizzando preferibilmente la funzione "Maxi cooking". Durante questa procedura il forno deve essere vuoto. Seguire le istruzioni a seguire per impostare correttamente la funzione.

Note: è opportuno ventilare la stanza durante e dopo il primo utilizzo.

USO QUOTIDIANO

1. SELEZIONARE UNA FUNZIONE

Per selezionare una funzione, ruotare la *manopola di selezione* in corrispondenza del simbolo della funzione desiderata: il display si accende e il forno emette un segnale acustico.



2. AVVIARE UNA FUNZIONE

MANUALE

Per avviare la funzione selezionata, ruotare la *manopola termostato* per impostare la temperatura desiderata.



Note: durante la cottura sarà possibile modificare la funzione ruotando la *manopola di selezione* o regolare la temperatura ruotando la *manopola termostato*.

La funzione non si avvia se la manopola del termostato è impostata su . Sarà possibile impostare durata, ora di fine cottura (solo se è impostata una durata) e timer.

AUTOMATICA

Per avviare la funzione automatica selezionata ("Pane" o "Torte dolci"), mantenere la *manopola del termostato* sulla posizione dedicata alle funzioni automatiche ().

Per terminare la cottura, ruotare la *manopola di selezione* in corrispondenza della posizione 0.

Note: sarà possibile impostare ora di fine cottura e timer.

LIEVITAZIONE

Per avviare la funzione "Lievitazione", ruotare la *manopola termostato* in corrispondenza del simbolo della funzione; se in corrispondenza di temperature differenti, la funzione non si avvierà.

Note: sarà possibile impostare durata, ora di fine cottura (solo se è impostata una durata) e timer.

3. PRERISCALDAMENTO

Una volta avviata la funzione, un segnale acustico e l'icona  lampeggiante sul display segnalano che si è attivata la fase di preriscaldamento.



Al termine di questa fase, un segnale acustico e l'icona  fissa sul display indicheranno che il forno ha raggiunto la temperatura impostata: a questo punto, inserire gli alimenti e procedere alla cottura.

Note: inserire gli alimenti nel forno prima della fine del preriscaldamento può compromettere i risultati di cottura.



. PROGRAMMARE LA COTTURA

Per programmare la cottura è necessario aver selezionato precedentemente una funzione.



DURATA

Premere  tante volte fino a che sul display lampeggiano l'icona  e "00:00".





Utilizzare  o  per impostare la durata desiderata, quindi premere  per confermare.

Attivare la funzione ruotando la *manopola termostato* in corrispondenza della temperatura desiderata o necessaria: un segnale acustico e il display avviseranno del termine della cottura.



Note: per annullare la durata impostata, premere  tante volte fino a che sul display lampeggia l'icona ; quindi utilizzare  per riportare la durata a "00:00".

La durata impostata include la fase di preriscaldamento.

PROGRAMMARE L'ORA DI FINE COTTURA / AVVIO RITARDATO

Una volta impostata una durata sarà possibile posticipare l'avvio della funzione, programmandone l'ora di fine: premere  fino a che sul display non lampeggiano l'icona  e l'ora corrente.



Utilizzare  o  per impostare l'ora di fine cottura desiderata e premere  per confermare.

Attivare la funzione ruotando la *manopola termostato* in corrispondenza della temperatura desiderata o necessaria: la funzione resterà in pausa fino ad avviarsi automaticamente dopo un periodo di tempo calcolato per terminare la cottura all'orario impostato.

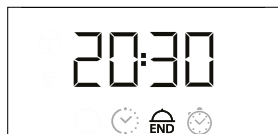

Note: per annullare l'impostazione, spegnere il forno ruotando la *manopola di selezione* sulla posizione "0".

Note: Il ritardo di avvio della funzionalità non è disponibile per le funzioni Grill e Turbo Grill.

FINE COTTURA

Un segnale acustico e il display avvisano del termine della funzione.





Ruotare la *manopola di selezione* per selezionare una funzione differente o sulla posizione "0" per spegnere il forno.



Note: se attivo il timer, il display mostrerà la scritta "END" in alternanza al tempo rimanente.

. IMPOSTARE IL TIMER

Questa opzione non interrompe né programma la cottura ma permette di utilizzare il display come contaminuti, sia durante una funzione attiva che quando il forno è spento.

Premere  tante volte fino a che sul display lampeggiano l'icona  e "00:00".



















































































Utilizzare  o  per impostare la durata desiderata e premere  per confermare.

Un segnale acustico avviserà del termine del conto alla rovescia.

Note: per disattivare il timer, premere  tante volte fino a che l'icona  lampeggia, quindi utilizzare  per riportare la durata a "00:00".

TABELLA DI COTTURA

RICETTA	FUNZIONE	PRERISC.	TEMPERATURA (°C)	DURATA (MIN)	LIVELLO E ACCESSORI
Torte a lievitazione		Sì	160 - 180	30 - 90	2/3 
		Sì	160 - 180	30 - 90	4  1 
Torte ripiene (cheese cake, strudel, torta di frutta)		Sì	160 - 200	35 - 90	2 
		Sì	160-200	40 - 90	4  2 
Biscotti/Tortine		Sì	160 - 180	20 - 45	3 
		Sì	150 - 170	20 - 45	4  2 
		Sì	150 - 170	20 - 45	5  3  1 
Bigné		Sì	180 - 210	30 - 40	3 
		Sì	180 - 200	35 - 45	4  2 
		Sì	180 - 200	35 - 45	5  3  1 
Meringhe		Sì	90	150 - 200	3 
		Sì	90	140 - 200	4  2 
		Sì	90	140 - 200	5  3  1 
Pizza / Focaccia		Sì	190 - 250	15 - 50	1 / 2 
		Sì	190 - 250	20 - 50	4  2 
Pane		-	-	60	2 
Pizza surgelata		Sì	250	10 - 20	3 
		Sì	230 - 250	10 - 25	4  2 
Torte salate (torta di verdura, quiche)		Sì	180 - 200	40 - 55	3 
		Sì	180 - 200	45 - 60	4  2 
		Sì	180 - 200	45 - 60	5  3  1 
Voulevant / Salatini di pasta sfoglia		-	190 - 200	20 - 30	3 
		-	180 - 190	20 - 40	4  2 
		-	180 - 190	20 - 40	5  3  1 

FUNZIONI								
	Statico	Grill	Turbo Grill	Pizza	Termoventilato	Maxi Cooking	Pane Auto	Eco Termoventilato
ACCESSORI								
	Griglia	Tortiera o teglia su griglia	Leccarda / Teglia su griglia	Leccarda	Leccarda con 200ml di acqua	TEGLIA		

RICETTA	FUNZIONE	PRERISC.	TEMPERATURA (°C)	DURATA (MIN)	LIVELLO E ACCESSORI
Lasagne / pasta al forno / cannelloni / sfornati		Sì	190 - 200	45 - 65	2
Agnello / Vitello / Manzo / Maiale 1 kg		Sì	190 - 200	80 - 110	3
Arrosto di maiale con cotenna 2kg		Sì	180 - 190	110 - 150	2
Pollo / Coniglio / Anatra 1 kg		Sì	200 - 230	50 - 100	2
Tacchino / Oca 3 kg		-	190 - 200	100 - 160	2
Pesce al forno / al cartoccio (filetto, intero)		Sì	170 - 190	30 - 45	2
Verdure ripiene (pomodori, zucchine, melanzane)		Sì	180 - 200	50 - 70	2
Pane tostato		-	250	2 - 6	5
Filetti / tranci di pesce		-	230 - 250	20 - 30*	4 3
Salsicce / Spiedini / Costine / Hamburger		-	250	15 - 30*	5 4
Pollo arrosto 1-1,3 kg		Sì	200 - 220	55 - 70**	2 1
Roast beef al sangue 1 kg		Sì	200 - 210	35 - 50**	3
Cosciotto di agnello / Stinchi		Sì	200 - 210	60 - 90**	3
Patate arrosto		Sì	200 - 210	35 - 55**	3
Verdure gratinate		-	200 - 210	25 - 55	3
Carne & Patate		Sì	190 - 200	45 - 100***	4 1
Pesce & Verdure		Sì	180	30 - 50***	4 1
Lasagna & Carne		Sì	200	50 - 100***	4 1
Pasto completo: Crostata (Liv. 5) / Lasagna (Liv. 3) / Carne (Liv. 1)		Sì	180 - 190	40 - 120***	5 3 1
Arrosti / Arrosti ripieni		-	170 - 180	100 - 150	2

La durata indicata non comprende la fase di preriscaldamento: si consiglia di inserire gli alimenti nel forno e di impostare la durata della cottura solo al raggiungimento della temperatura desiderata.

* Ruotare il cibo a metà cottura.

** Ruotare il cibo a due terzi di cottura se necessario.

*** La durata è approssimata: le pietanze possono essere tolte dal forno in tempi differenti secondo preferenza.

Scaricare le Istruzioni per l'uso da

docs.bauknecht.eu per consultare la tabella delle ricette testate, compilata per gli istituti di valutazione secondo la norma CEI 60350-1.

FUNZIONI								
	Statico	Grill	Turbo Grill	Pizza	Termoventilato	Maxi Cooking	Pane Auto	Eco
ACCESSORI								
	Griglia	Tortiera o teglia su griglia	Leccarda / Teglia su griglia	Leccarda	Leccarda con 200ml di acqua	TEGLIA		

PULIZIA E MANUTENZIONE



Per maggiori informazioni, scaricare le istruzioni per l'uso da docs.bauknecht.eu

Non usare pulitrici a getto di vapore.

Utilizzare guanti protettivi durante tutte le operazioni.

Eseguire le operazioni indicate a forno freddo.

Scollegare l'apparecchio dalla rete elettrica.

Non usare pagliette metalliche, panni abrasivi e detersivi abrasivi o corrosivi che possano danneggiare le superfici.

SUPERFICI ESTERNE

- Pulire le superfici con un panno in microfibra umido. Se molto sporche, aggiungere qualche goccia di detersivo neutro. Asciugare con un panno asciutto.
- Non usare detersivi corrosivi o abrasivi. Se inavvertitamente uno di questi prodotti dovesse venire a contatto con le superfici, pulire subito con un panno in microfibra umido.

SUPERFICI INTERNE

- Dopo ogni uso, lasciare raffreddare il forno e pulirlo preferibilmente quando è ancora tiepido per rimuovere incrostazioni e macchie dovute a residui di cibo; per asciugare la condensa dovuta alla cottura di alimenti con un elevato contenuto di acqua, usare a forno freddo un panno o una spugna.

- Per facilitare la pulizia dei vetri è possibile rimuovere e smontare facilmente la porta.
- Pulire i vetri della porta con detersivi liquidi specifici.
- La resistenza superiore del grill può essere abbassata per pulire la parete superiore del forno: estrarre la resistenza dalla sede e abbassarla. Per reinserire la resistenza in posizione, sollevarla, tirarla leggermente verso di sé e controllare che il supporto sia posizionato correttamente.

ACCESSORI

Mettere a bagno gli accessori con detersivo per piatti dopo l'uso, maneggiandoli con guanti da forno, se ancora caldi. I residui di cibo possono essere rimossi con una spazzola per piatti o con una spugna.

TOGLIERE E RIMONTARE LA PORTA

1. Per rimuovere la porta, aprirla completamente e abbassare i fermi fino alla posizione di sblocco.

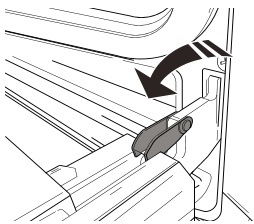

2. Chiudere la porta fino a quando è possibile. Prendere saldamente la porta con entrambe le mani, evitando di tenerla per la maniglia. Per estrarla facilmente, continuare a chiuderla e contemporaneamente tirarla verso l'alto (a) finché non esce dalle sedi (b).

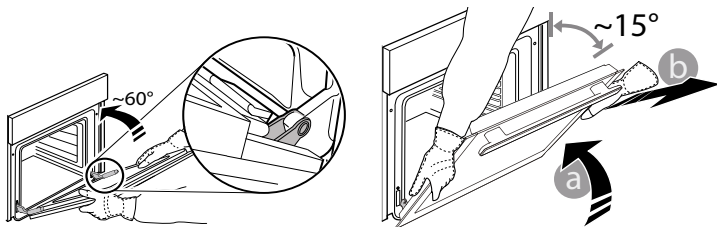

Togliere la porta e appoggiarla su un piano morbido.

3. Per rimontare la porta, avvicinarla al forno allineando i ganci delle cerniere alle proprie sedi e ancorare la parte superiore agli alloggiamenti.

4. Abbassare la porta e poi aprirla completamente. Abbassare i fermi nella posizione originale: fare attenzione che siano completamente abbassati.

5. Provare a chiudere la porta, verificando che sia allineata al pannello di controllo. Se non lo fosse, ripetere tutte le operazioni.

CLICK&CLEAN - PULIRE IL VETRO

1. Dopo aver smontato la porta e averla appoggiata su un ripiano morbido con la maniglia verso il basso, premere contemporaneamente le due clip di fissaggio ed estrarre il profilo superiore della porta tirandolo verso di sé

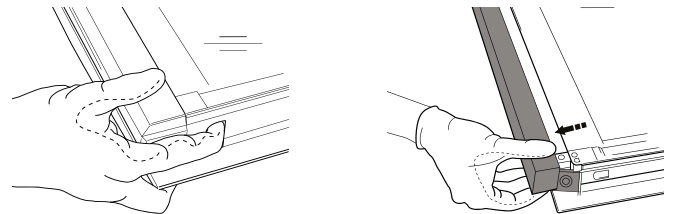

2. Sollevare e prendere saldamente il vetro interno con due mani, rimuoverlo e appoggiarlo su un piano morbido prima di eseguire la pulizia.

3. Per riposizionare correttamente il vetro interno, fare attenzione che la "R" sia leggibile nell'angolo destro e che la superficie lucida (non stampata) sia rivolta verso l'alto. Inserire dapprima il lato lungo del vetro indicato dalla "R" nelle sedi di sostegno, quindi abbassarlo in posizione.

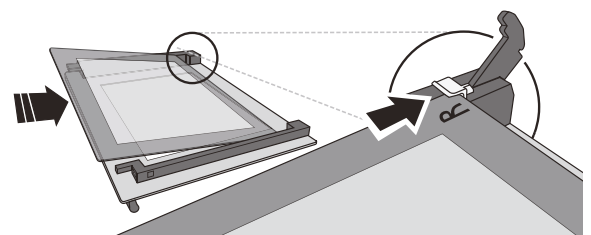

4. Rimontare il profilo superiore: un clic indica il corretto posizionamento. Verificare che la tenuta sia salda prima di rimontare la porta.

Problema	Possibile causa	Soluzione
Il forno non funziona	Interruzione di corrente elettrica. Disconnessione dalla rete principale	Verificare che ci sia tensione in rete e che il forno sia collegato all'alimentazione elettrica. Spegnere e riaccendere il forno e verificare se l'inconveniente persiste
Il display mostra la lettera "F" seguita da un numero	Problema software	Contattare il più vicino Servizio Assistenza Clienti e specificare il numero che segue la lettera "F"

CONSIGLI UTILI



Per maggiori informazioni, scaricare le istruzioni per l'uso da docs.bauknecht.eu

COME LEGGERE LA TABELLA DI COTTURA

La tabella indica la funzione, gli accessori e il livello migliore da utilizzare per cuocere svariati tipi di cibo. I tempi di cottura si riferiscono all'introduzione del cibo nel forno, escluso il preriscaldamento (dove richiesto). Le temperature e i tempi di cottura sono indicativi e dipendono dalla quantità di cibo e dal tipo di accessori. Utilizzare inizialmente i valori più bassi consigliati e, se il risultato della cottura non è quello desiderato, passare a quelli più alti. Si consiglia di utilizzare gli accessori in dotazione e tortiere o teglie possibilmente in metallo scuro. È possibile utilizzare anche pentole e accessori in pyrex o in ceramica, i tempi di cottura si allungheranno leggermente.

CUCINARE DIFFERENTI ALIMENTI CONTEMPORANEAMENTE

Utilizzando la funzione "Termoventilato", è possibile cuocere contemporaneamente cibi diversi (ad esempio: pesce e verdure), su Ripiani diversi. Estrarre i cibi che richiedono tempi di cottura inferiori e lasciare continuare la cottura per quelli con tempi più lunghi.

FUNZIONE PANE AUTO

Per ottenere i migliori risultati è opportuno seguire attentamente le indicazioni, rispettando la ricetta per 1000g d'impasto: 600g di farina, 360g di acqua, 11g di sale, 25g di lievito fresco (oppure 2 bustine di lievito in polvere).

Per una lievitazione ottimale, sono necessari circa 90 minuti a temperatura ambiente oppure 60 minuti all'interno del forno attivando la funzione "Lievitazione".

Infornare a forno freddo, versare 1 dl di acqua potabile fredda sul fondo del forno e avviare la funzione "Pane Auto". Al termine della cottura, lasciare riposare su una griglia fino a completo raffreddamento..

DATI TECNICI

La scheda tecnica del prodotto con i dati del consumo energetico è scaricabile dal sito web docs.bauknecht.eu

COME OTTENERE LE ISTRUZIONI PER L'USO

> Scaricare le Istruzioni per l'uso dal sito web docs.bauknecht.eu (è possibile utilizzare questo codice QR) specificando il codice prodotto.



> In alternativa, contattare il Servizio di Assistenza Clienti

CONTATTARE IL SERVIZIO ASSISTENZA CLIENTI

I contatti possono essere trovati sul manuale di garanzia. Prima di contattare il Servizio Assistenza, prepararsi a fornire i codici riportati sulla targhetta matricola del prodotto.

