

# VODIČ ZA SVAKODNEVNU UPOTREBU



## ZAHVALJUJEMO VAM NA KUPOVINI PROIZVODA HOTPOINT - ARISTON

Kako biste dobili potpuniju pomoć i podršku, svoj proizvod registrirajte na [www.hotpoint.eu/register](http://www.hotpoint.eu/register)



Sigurnosne upute i Vodič za upotrebu i održavanje možete preuzeti tako da posjetite naše web-mjesto [docs.hotpoint.eu](http://docs.hotpoint.eu) i slijedite upute na poledini ove knjižice.



**Prije upotrebe uređaja pažljivo pročitajte vodič za zdravlje i sigurnost.**

## OPIS PROIZVODA

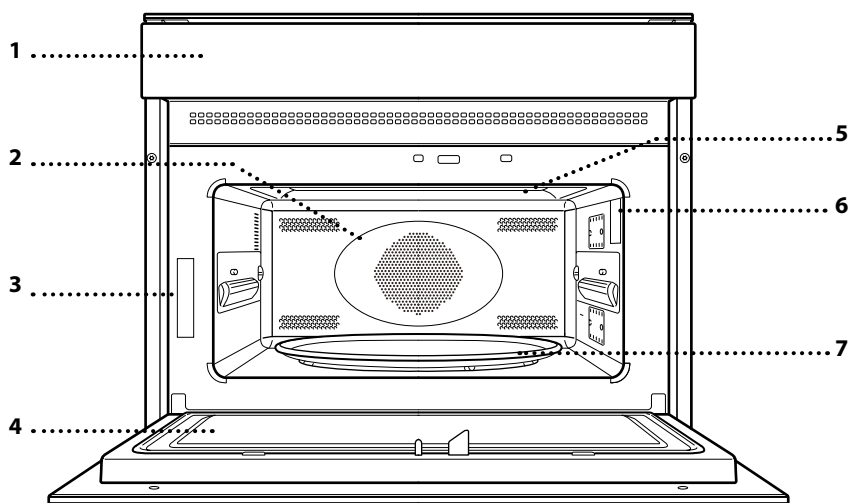

1. Upravljačka ploča
2. Kružni grijač (ne vidi se)
3. Identifikacijska pločica (ne skidati)
4. Vrata
5. Gornji grijač/roštilj
6. Svjetlo
7. Okretni tanjur

## KONTROLNA PLOČA

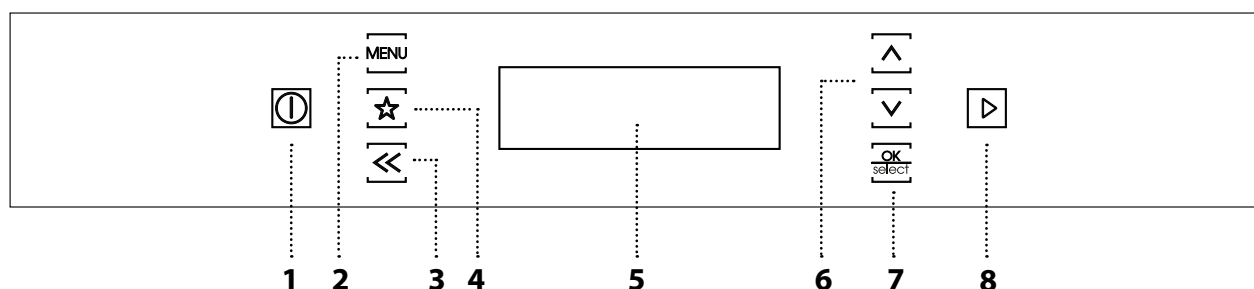

### 1. UKLJUČIVANJE/ ISKLJUČIVANJE

Za uključivanje i isključivanje pećnice ili zaustavljanje uključene funkcije.

### 2. IZBORNIK

Za pristup popisu funkcija.

### 3. NATRAG

Za povratak na prethodni izbornik.

### 4. FAVORITI

Za pristup popisu najčešće upotrebljivanih funkcija.

### 5. ZASLON

### 6. GUMBI ZA NAVIGACIJU

Za pregledavanje popisa funkcija, pomicanje pokazivača i promjenu postavki funkcije.

### 7. GUMB ZA POTVRĐIVANJE

Za potvrdu odabira funkcije ili postavljene vrijednosti.

### 8. POKRETANJE

Za trenutno pokretanje funkcije. Kada je pećnica isključena, on pokreće funkciju mikrovalne pećnice "Jet Start".

## OKRETNI TANJUR

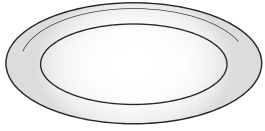

Postavljen na nosač okretni tanjur može se upotrebljavati u svim načinima kuhanja. Okretni tanjur uvijek se mora upotrebljavati kao postolje za sve ostale spremnike ili pribor, osim za pravokutni lim za pečenje.

## NOSAČ OKRETNOG TANJURA

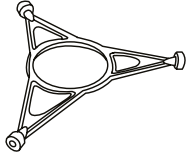

Nosač upotrebljavajte samo za okretni tanjur. Na nosač ne postavljajte ostali pribor.

## CRISP TANJUR

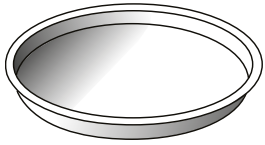

Upotrebljava se samo za posebnu funkciju "Dynamic Crisp". Crisp tanjur uvijek se mora postaviti u središte okretnog tanjura i može se zagrijati kada je prazan koristeći posebnu, tome namijenjenu, funkciju. Namirnice stavite izravno na Crisp tanjur.

## RUČICA CRISP TANJURA

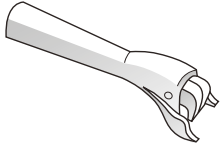

Korisna prilikom vađenja vrućeg Crisp tanjura iz pećnice.

## PRAVOKUTNI LIM ZA PEČENJE

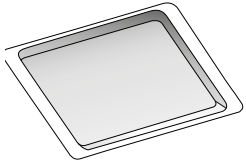

Lim za pečenje upotrebljavajte samo s funkcijama koje omogućuju konvekcijsko pečenje; Nikada se ne smije upotrebljavati u kombinaciji s mikro valovima. Lim umetnite vodoravno tako da je oslonjen na stalak u odjeljku za kuhanje.

Napomena: Ne morate vaditi okretni tanjur i njegov nosač kada upotrebljavate pravokutni lim za pečenje.

Napomena: Broj komada dodatnog pribora može varirati, ovisno o kupljenom modelu. Ostali dodatni pribor može se odvojeno kupiti u postprodajnom servisu.

## NISKA REŠETKA

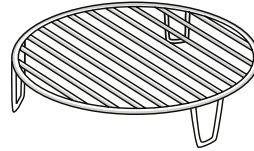

Ona omogućuje da se namirnice postave bliže roštilju kako bi se jelo savršeno zapeklo i postiglo optimalno kruženje vrućeg zraka. Rešetku postavite na okretni tanjur pazeći da ne dolazi u doticaj s drugim površinama.

## POSUDA ZA KUHANJE NA PARI

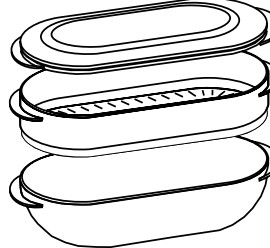

1 Za kuhanje na pari namirnica kao što je riba ili povrće, postavite ih u košare (2) i ulijte pitku vodu (100 ml) na dno posude za kuhanje na pari (3) kako bi se dobila prava količina pare.

Namirnice kao što su tjestenina, riža ili krumpiri kuhajte tako da ih stavite izravno na dno posude za kuhanje na pari (košara nije potrebna) i dodajte količinu pitke vode koja odgovara količini koju kuhate.

Za najbolje rezultate posudu za kuhanje na pari pokrijte isporučnim poklopcem (1). Posudu za kuhanje na pari uvijek postavljajte na okretni tanjur i upotrebljavajte je samo s odgovarajućim funkcijama kuhanja ili funkcijama mikrovalne pećnice.

## POKLOPAC

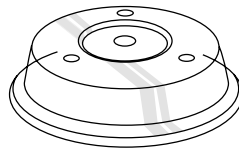

Koristan za pokrivanje jela dok se kuha ili grije u mikrovalnoj pećnici. Poklopac smanjuje prskanje, zadržava vlagu jela, a može se upotrebljavati i za stvaranje dvije razine za pečenje.

Nije prikladan za konvekcijsko pečenje ni za bilo koju funkciju roštilja (uključujući i "Dynamic Crisp").

**Na tržištu je raspoloživ brojni pribor. Prije kupovine provjerite jesu li prikladni za upotrebu u mikrovalnim pećnicama i otporni na temperature pećnice.**

**Metalni spremnici za jelo ili piće nikada se ne smiju upotrebljavati prilikom kuhanja u mikrovalnoj pećnici.**

**Uvijek provjerite da jelo i pribor ne dolaze u doticaj s unutarnjim stjenakama pećnice.**

**Uvijek osigurajte da se okretni tanjur slobodno okreće prije aktiviranja pećnice. Pazite da okretni tanjur ne sklizne s ležišta prilikom umetanja ili vađenja drugog pribora.**

**MANUAL (PRIRUČNIK)** **MICROWAVE (MIKROVALOVI)**

Za brzo kuhanje ili zagrijavanje jela ili napitaka.

SNAGA	PREPORUČENI NAČIN UPOTREBE
<b>900 W</b>	Brzo zagrijavanje napitaka ili drugih jela s visokim udjelom vode
<b>750 W</b>	Kuhanje povrća
<b>650 W</b>	Kuhanje mesa i ribe
<b>500 W</b>	Kuhanje mesnih umaka ili umaka koji sadrže sir ili jaje. Završavanje mesnih pita ili zapečene tjestenine
<b>350 W</b>	Sporo, lagano kuhanje. Savršeno za otapanje maslaca ili čokolade
<b>160 W</b>	Odležavanje zamrznutih jela ili omekšavanje maslaca i sira
<b>90 W</b>	Omekšavanje sladoleda

Preporučeni pribor: Poklopac

**DYNAMIC CRISP**

Za savršeno zapečena jela, s gornje i donje strane jela. Ova se funkcija mora upotrebljavati samo s posebnim Crisp tanjurom.

Potreban pribor: Crisp tanjur, ručica Crisp tanjura

**GRILL (ROŠTILJ)**

Za stvaranje korice, roštiljanje i gratinirana jela. Preporučujemo okretanje jela prilikom pečenja. Za najbolje rezultate roštilj zagrijavajte 3 – 5 minuta.

Preporučeni pribor: rešetka

**GRILL + MICROWAVE (ROŠTILJ + MIKROVALOVI)**

Za brzo kuhanje i gratiniranje jela uz kombinaciju funkcija mikrovalova i roštilja.

Preporučeni pribor: rešetka

**TURBO GRILL (TURBO ROŠTILJ)**

Za savršene rezultate uz kombinaciju funkcija roštilja i konvekcijskog pečenja. Preporučujemo okretanje jela prilikom pečenja.

Preporučeni pribor: rešetka

**TURBO GRILL + MICROWAVE (TURBO ROŠTILJ + MIKROVALOVI)**

Za brzo kuhanje i stvaranje zapečene korice jela uz kombinaciju funkcija mikrovalova, roštilja i konvekcijske pećnice.

Preporučeni pribor: rešetka

**FORCED AIR (PRISILNO KRUŽENJE ZRAKA)**

Za kuhanje jela na način kojim se postižu rezultati slični kao kod upotrebe klasične pećnice. Lim za pečenje ili drugo posuđe prikladno za pećnicu može se upotrebljavati za pripremu određenih namirnica.

Preporučeni pribor: Pravokutni lim za pečenje/rešetka

**FORCED AIR + MICROWAVES (PRISILNO KRUŽENJE ZRAKA + MIKROVALOVI)**

Za brzo pripremanje jela u pećnici.

Preporučeni pribor: rešetka

**QUICK HEAT (BRZO ZAGRIJAVANJE)**

Za brzo zagrijavanje pećnice prije ciklusa pečenja. Pričekajte da funkcija završi prije stavljanja hrane u pećnicu.

**SENSOR (SENZOR)**

Funkcije senzora neprestano se prilagođavaju tijekom pečenja omogućujući postizanje izvrsnih rezultata. Ukupno vrijeme ne uključuje pripremu ili faze grijanja.

**DYNAMIC REHEAT**

Za zagrijavanje gotove hrane koja je bila zamrznuta ili na sobnoj temperaturi. Pećnica automatski izračunava vrijednosti za postizanje najboljih mogućih rezultata u najkraćem vremenu. Stavite namirnice u zdjelu ili na tanjur, prikladne za mikrovalove i otporne na toplinu.

**DYNAMIC CRISP**

Za brzo zagrijavanje i kuhanje zamrznute hrane, za zlaćanu, hrskavu koricu. Za ovu funkciju upotrebljavajte isključivo s isporučenim Crisp tanjurom.

Potreban pribor: Crisp tanjur, ručica Crisp tanjura

**DYNAMIC STEAM**

Za kuhanje na pari namirnica kao što su povrće ili riba upotrebljavajući isporučenu posudu za kuhanje na pari.

Faza pripreme automatski stvara paru dovodeći do ključanja vode u posudi za kuhanje na pari. Trajanje te faze može varirati. Pećnica zatim nastavlja s kuhanjem namirnica na pari u skladu s postavljenim vremenom.

Neka od vremena kuhanja su sljedeća:

- svježe povrće (250 – 500 g): 4 – 6 minuta;
- zamrznuto povrće (250 – 500 g): 5 – 7 minuta;
- riblji fileti (250 – 500 g): 4 – 6 minuta.

Potreban pribor: Posuda za kuhanje na pari



## KEEP WARM (ODRŽAVANJE TOPLINE)

Za održavanje netom ispečene hrane toplom i hrskavom, uključujući meso, pržena jela ili torte.

## AUTO AUTOMATIC (AUTOMATSKI)

Pomoću ove automatske funkcije samo odaberite težinu ili količinu namirnica za postizanje najboljih mogućih rezultata.



### DYNAMIC DEFROST

Za brzo odmrzavanje mesa, peradi, ribe, povrća i kruha težine između 100 g i 3 kg. Namirnice treba postaviti izravno na okretni tanjur.



### CRISPY BREAD DEFROST (ODMRZAVANJE HRKAVOG KRUHA)

Za brzo odmrzavanje i zagrijavanje rolica, croissanta i bageta. Pećnica automatski izračunava vrijednosti za postizanje najboljih mogućih rezultata (vrijeme, snagu i način kuhanja).

Potrebni pribor: Crisp tanjur, ručica Crisp tanjura



### RECIPES (RECEPTI)

**AUTO** To vam omogućuje odabir iz cijelog niza automatskih recepata s unaprijed postavljenim vrijednostima za optimalno kuhanje. Za najbolje rezultate slijedite upute prikazane na zaslону.

Napomena: Za više informacija, recepta i korisnih savjeta pročitajte i preuzmite Vodič za upotrebu i održavanje na [docs.hotpoint.eu](http://docs.hotpoint.eu)



## SETTINGS (POSTAVKE)

Za promjenu postavki pećnice (jezik, vrijeme, glasnoća zvučnih signala, svjetlina, ekonomični način rada).

Napomena: Kada je uključen ekonomični način rada, svjetlina zaslona smanjit će se nakon nekoliko sekundi kako bi se uštedjela energija. Zaslón se ponovno automatski uključuje kada god se pritisne neki od gumba itd.

# PRVA UPOTREBA PEĆNICE

## 1. ODABERITE JEZIK

Morat ćete postaviti jezik i vrijeme kada prvi put uključujete uređaj. Na zaslónu će se prikazati popis raspoloživih jezika.

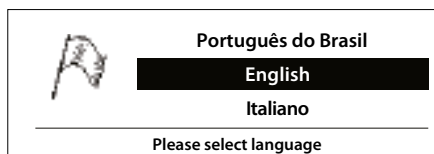

Upotrijebite **▲** ili **▼** za odabir željenog jezika i pritisnite **OK select** za potvrdu.

Napomena: Jezik se može i kasnije promijeniti u stavci izbornika "Postavke".

## 2. POSTAVITE VRIJEME

Nakon odabira jezika trebat će postaviti trenutno vrijeme: na zaslónu će treperiti 12:00.

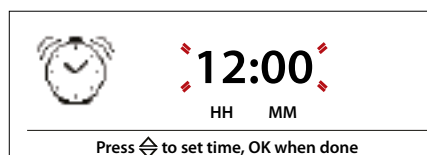

Upotrijebite **▲** ili **▼** za postavljanje vremena i pritisnite **OK select** za potvrdu.

Napomena: Vrijeme će možda trebati ponovno namjestiti nakon duljih nestanaka struje.

# SVAKODNEVNA UPORABA

## 1. ODABERITE FUNKCIJU

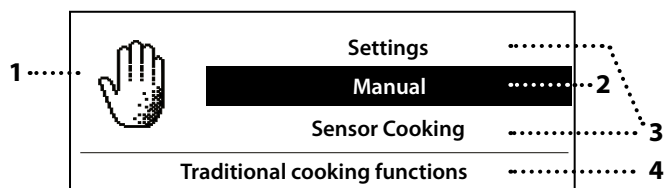

### UKLJUČITE PEĆNICU

Pritisnite : Na zaslonu će se prikazati glavni izbornik.

### PREGLEDAVANJE IZBORNIKA

Pritisnite ili za pregledavanje glavnog izbornika i označite funkciju koju želite odabrati.

1. Simbol odabrane funkcije
2. Odabrana funkcija
3. Ostale dostupne funkcije
4. Opis odabrane funkcije

### ODABIR STAVKE IZBORNIKA

Kada na zaslonu označite stavku koju želite odabrati pritisnite za potvrdu i idite na izbornik postavki (pogledajte u nastavku) ili na popis funkcija.

### ODABERITE FUNKCIJU

Pritisnite ili pregledajte dobiveni popis. Pritisnite za potvrdu i idite na izbornik postavki.

## 2. POSTAVLJANJE I UKLJUČIVANJE FUNKCIJE

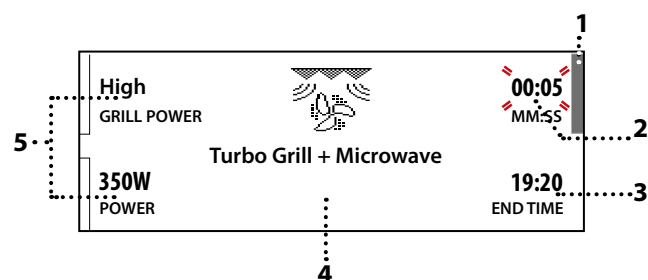

1. Pokazivač birača (označava odabranu postavku)
2. Trajanje
3. Vrijeme kada će funkcija završiti
4. Naziv funkcije
5. Postavke funkcije (snaga, temperatura, razina roštilja, težina ili kvaliteta, željena razina kuhanja itd.)

### PRIMIENITE POSTAVKE

Na početku mogu se postaviti vrijednosti odabrane funkcije na temelju sekvence prikazane na zaslonu. Kada vrijednost treperi, upotrijebite ili za postavljanje vremena i pritisnite za potvrdu.

Po potrebi upotrijebite ili za pomicanje pokazivača pored vrijednosti koju želite promijeniti i pritisnite . Vrijednost će treperiti.

Upotrijebite ili za promjenu vrijednosti i pritisnite za potvrdu.

### UKLJUČITE FUNKCIJU

Kada se prikažu tražene postavke pritisnite za uključivanje funkcije.

Napomena: Gdje je to moguće, neke se vrijednosti mogu promijeniti i tijekom kuhanja.

## . SIGURNOSNI UREĐAJ

Ta se funkcija automatski uključuje kako bi se spriječilo slučajno uključivanje pećnice.



Otvorite i zatvorite vrata pa zatim pritisnite za pokretanje odabrane funkcije.

## . PAUZA



Za pauziranje uključene funkcije, na primjer za miješanje ili okretanje jela, samo otvorite vrata. Za ponovno pokretanje zatvorite vrata i pritisnite .

## . JET START





Kada je pećnica isključena pritisnite za pokretanje kuhanja s funkcijom mikrovalova pune snage (900 W) u trajanju od 30 sekundi.

Svakim ponovnim pritiskom gumba vrijeme kuhanja povećava se za dodatni 30 sekundi.

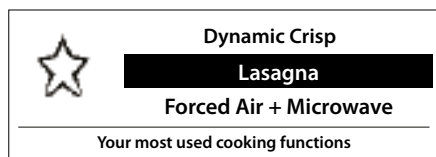
## . FAVORITI

Pećnica će automatski sastaviti popis funkcija koje najčešće upotrebljavate. Pritisnite  gumb za uključivanje pećnice, zatim pritisnite  za prikaz popisa najčešće upotrebljivanih funkcija.



Upotrijebite  ili  za odabir potrebne funkcije, pritisnite  za potvrdu i zatim izmijenite, ako je potrebno, postavke prema svojim potrebama (ponuđene su osnovne postavke). Po završetku pritisnite  za uključivanje funkcije.

## . PREOSTALA TOPLINA

U većini slučajeva, kada se jelo skuha, pećnica automatski pokreće postupak hlađenja koji se navodi na zaslону.

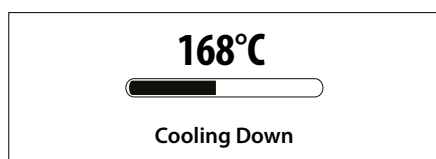





Za prikaz sata tijekom tog postupka pritisnite .

Napomena: Otvaranje vrata privremeno prekida postupak.

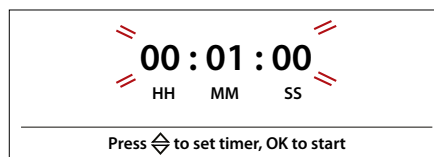
## . MJERAČ VREMENA

Kada je pećnica isključena zaslon se može upotrebljavati kao mjerač vremena. Za uključivanje funkcije pritisnite . Mjerač vremena treperit će na zaslonu.





Pritisnite  ili  za postavljanje vremena koje trebate i zatim pritisnite  za uključivanje mjerača vremena. Kada mjerač vremena završi s odbrojanjem odabranog trajanja oglasit će se zvučni signal.





























Napomena: Mjerač vremena ne uključuje niti jedan ciklus kuhanja.

Za isključivanje mjerača vremena u bilo kojem trenutku pritisnite .

## . ZAKLJUČAVANJE TIPKI

Za zaključavanje tipku istovremeno pritisnite i držite  i  najmanje pet sekundi. Isto ponovite za otključavanje tipki.

# TABLICA KUHANJA

JELO	FUNKCIJA	ZAGRIJAVANJE	TEMP. (°C)/ RAZINA ROŠTILJA	SNAGA (W)	TRAJANJE	DODATNI PRIBOR
<b>Biskvitna tijesta</b>		-	160 – 180	-	30 – 60	 
		-	160 – 180	90	25 – 50	 
<b>Nadjevne pite</b> (sirnica, savijača od jabuka, pita od jabuka)		Da	160 – 190	-	35 – 70	 
<b>Kolačići</b>		Da	170 – 180	-	10 – 20	
<b>Poljupci</b>		Da	100 – 120	-	40 – 50	
<b>Kruščići</b>		Da	210 – 220	-	10 – 12	
<b>Štruca kruha</b>		Da	180-200	-	30-35	
<b>Pizza / Pita</b>		Da	190-220	-	20-40	
<b>Pizza</b> (0,4 – 0,5 kg)		-	-	-	14-16	
<b>Sočne pite</b> (pita od povrća, quiche Lorraine)		Da	180 – 190	-	40 – 55	 
<b>Quiche Lorraine</b> (1 – 1,2 kg)		-	-	-	18-20	
<b>Lasagne / Zapečena tjestenina</b>			Srednja	350-500	15-40	 

JELO	FUNKCIJA	ZAGRIJAVANJE	TEMP. (°C)/ RAZINA ROŠTILJA	SNAGA (W)	TRAJANJE	DODATNI PRIBOR
<b>Pečena janjetina/teletina/ pečena govedina</b> (1,3 – 1,5 kg)		–	170 – 180	–	70–80*	
		–	160–180	160	50–70*	
<b>Pečena govedina – srednje pečena</b> (1,3 – 1,5 kg)		–	170–180	–	40–60*	
<b>Pečena piletina/kunić/patka</b> (cijelo 1 – 1,2 kg)		–	210 – 220	–	50–70*	
		–	210–220	350	45–60*	
<b>Pile / kunić/ patka</b> (fileti/komadi)		–	Srednje visoka	350 – 500	20–40*	
<b>Komadi piletine</b> (0,4 – 1 kg)		–	–	–	12–18	
<b>Pečena cijela riba</b> (cijela)		–	Visoka	160 – 350	20 – 40	
<b>Riblji fileti/komadi</b>		Da	Visoka	–	15–30*	
<b>Punjeno povrće</b> (rajčice, tikvice, patlidžani)		–	Srednja	500 – 650	25 – 50	
<b>Tost</b>		–	Visoka	–	3 – 6	
<b>Kobasice/ražnjići/rebarca/ pljeskavice</b>		–	Srednje visoka	–	20–40*	
<b>Kobasice/hamburgeri</b> (0,2 – 1 kg)		Da**	–	–	6–16	
<b>Pečeni krumpiri</b>		–	Srednja	350–500	20–40*	
<b>Pekarski krumpir</b> (0,3 – 0,8 kg)		–	–	–	10 – 20	
<b>Pečeno voće</b>		–	Srednja	160 – 350	15 – 25	
<b>Zapečeno povrće</b>		–	Jako – srednje	–	15 – 25	
<b>Prženo povrće</b> (0,3 – 0,8 kg)		Da**	–	–	8 – 18	

\* Okrenite hranu na polovici pečenja

\*\* Crisp tanjur zagrijavajte 3 – 5 minuta

[www](http://www.docs.hotpoint.eu) Za više informacija, recepata i korisnih savjeta pročitajte i preuzmite Vodič za upotrebu i održavanje na **docs.hotpoint.eu**

[www](http://www.docs.hotpoint.eu) Vodič za upotrebu i održavanje preuzmite na **docs.hotpoint.eu** kako biste dobili tablicu isprobanih recepata sastavljenu za ovlaštena tijela za certificiranje u skladu sa standardima IEC 60705 i IEC 60350.

FUNKCIJE	Crisp	Grill (Roštilj)	Grill + Microwave (Roštilj + Mikrovalovi)	Turbo Grill (Turbo roštilj)	Forced Air (Prisilno kruženje zraka)	Forced Air + Microwave (Prisilno kruženje zraka + Mikrovalovi)
DODATNI PRIBOR	Ploča otporna na toplinu/spremnik prikladan za upotrebu u mikrovalnoj pećnici 		Niska rešetka 	Tanjur Crisp 	Pravokutni lim za pečenje 	

# ČIŠĆENJE

Provjerite je li se uređaj ohladio prije obavljanja zahvata održavanja ili čišćenja.

Nemojte koristiti uređaje za čišćenje parim.

Ne upotrebljavajte čeličnu vunu, abrazivne žice ili abrazivna/korozivna sredstva za čišćenje jer bi to moglo oštetiti površinu uređaja.

## UNUTARNJE I VANJSKE POVRŠINE

- Očistite površine vlažnom krpom od mikrovlakana. Ako su jako prljave, dodajte vodi nekoliko kapi pH neutralnog deterdženta. Na kraju obrišite suhom krpom.
- Staklo vrata čistite odgovarajućim tekućim deterdžentom.
- U redovitim intervalima ili u slučaju prskanja, izvadite okretni tanjur i nosač kako biste očistili dno pećnice i uklonili sve ostatke hrane.
- Roštilj ne treba čistiti jer visoka temperatura sagorijeva prljavštinu. Tu funkciju redovito upotrebljavajte.

## DODATNI PRIBOR

- Sav pribor može se prati u perilici posuđa osim Crisp tanjura.
- Crisp tanjur treba prati vodom i blagim deterdžentom. Tvrdokornu prljavštinu lagano istrljajte krpom. Uvijek ostavite Crisp tanjur da se ohladi prije čišćenja.

## RJEŠAVANJE PROBLEMA



Za više informacija preuzmite Vodič za upotrebu i održavanje s web-mjesta [docs.hotpoint.eu](http://docs.hotpoint.eu)

Problem	Mogući uzrok	Rješenje
Pećnica ne radi.	Nestalo je struje. Došlo je do isključenja iz mreže.	Provjerite ima li struje u mreži i je li pećnica ukopčana u struju. Isključite i ponovno uključite pećnicu kako biste provjerili javlja li se kvar i dalje.
Pećnica stvara zvukove čak i kada je isključena.	Uključen ventilator za hlađenje.	Otvorite vrata ili pričekajte da završi postupak hlađenja.
Ako zaslom pokazuje slovo "F" iza kojeg slijedi broj.	Softverska pogreška.	Obratite se najbližem postprodajnom servisu za korisnike i navedite broj iza kojeg slijedi slovo "F".

## OBRAZAC PROIZVODA

Letak proizvoda s podacima o potrošnji energije može se preuzeti na web-mjestu [docs.hotpoint.eu](http://docs.hotpoint.eu)

## NAČIN DOBIVANJA VODIČA ZA UPOTREBU I ODRŽAVANJE

> Vodič za upotrebu i održavanje preuzmite s našeg web-mjesta

[docs.hotpoint.eu](http://docs.hotpoint.eu)

(možete upotrijebiti ovaj QR kod) navodeći prodajnu šifru proizvoda.



> Ili kontaktirajte naš postprodajni servis za korisnike.

## KONTAKTIRANJE NAŠEG PROSTPRODAJNOG SERVISA

Podatke za kontakt možete pronaći u priručniku jamstva. Kada se obraćate našem postprodajnom servisu za korisnika navedite kodove navedene na identifikacijskoj pločici proizvoda.

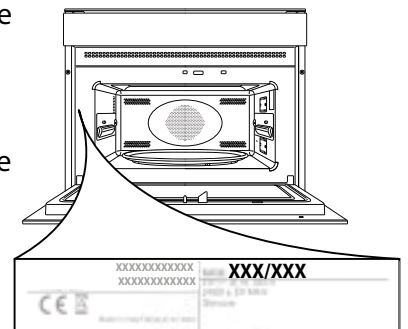



# NAVODILA ZA VSAKODNEVNO UPORABO



**HVALA, DA STE KUPILI IZDELEK ZNAMKE HOTPOINT – ARISTON**

Da vam bomo lahko nudili vsestransko pomoč in podporo, registrirajte svoj aparat na spletni strani [www.hotpoint.eu/register](http://www.hotpoint.eu/register).



Varnostna navodila in navodila za uporabo in vzdrževanje lahko prenesete z naše spletne strani [docs.hotpoint.eu](http://docs.hotpoint.eu), za kar upoštevajte navodila na zadnji strani te knjižice.



**Pred uporabo aparata pozorno preberite navodila za varovanje zdravja in varnost.**

## OPIS IZDELKA

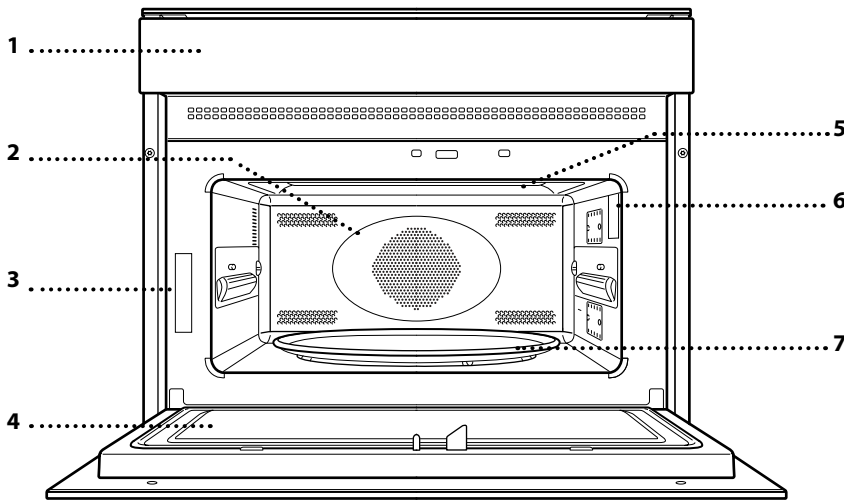

1. Nadzorna plošča
2. Okrogli grelnik (ni viden)
3. Identifikacijska ploščica (ostati mora nameščena)
4. Vrata
5. Zgornji grelnik/žar
6. Luč
7. Vrtljiva plošča

## UPRAVLJALNA PLOŠČA

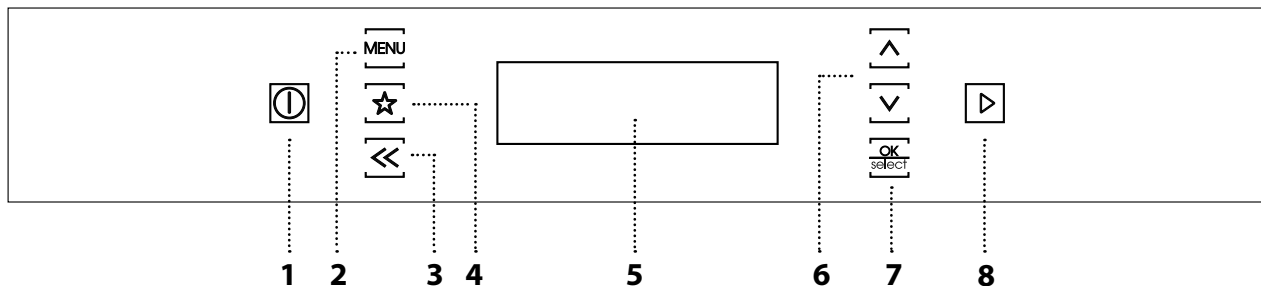

### 1. VKLOP/IZKLOP

Tipka za vklop in izklop pečice in za prekinitvev aktivne funkcije.

### 2. MENI

Za dostop do seznama funkcij.

### 3. NAZAJ

Tipka za vrnitev v predhodni meni.

### 4. PRILJUBLJENE

Za dostop do seznama najpogosteje uporabljanih funkcij.

### 5. ZASLON

### 6. NAVIGACIJSKI TIPKI

Za drsenje po seznamu funkcij, premikanje kazalca in spreminjanje nastavitvev funkcije.

### 7. GUMB ZA POTRDITEV

Za potrditev izbire funkcije ali nastavljenih vrednosti.

### 8. ZAGON

Za takojšen zagon funkcije. Ko je pečica izklopljena, se vklopi funkcija mikrovalovne pečice „**Jet Start**“.

# Hotpoint

ARISTON

## VRTLJIV KROŽNIK

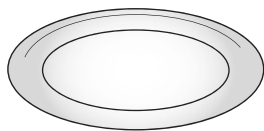

Steklen vrtljivi krožnik, nameščen na podstavku, se lahko uporablja pri vseh načinih priprave. Vrtljivi krožnik je treba vedno uporabiti kot podlago za druge posode in pribor, z izjemo

pravokotnega pekača.

## PODSTAVEK VRTLJIVEGA KROŽNIKA

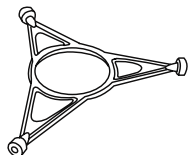

Uporabljajte le originalni podstavek za steklen vrtljivi krožnik. Na podstavek ne polagajte drugega pribora.

## KROŽNIK CRISP

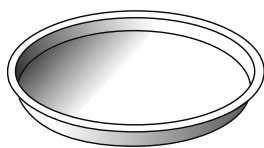

Uporabljajte le s posebno funkcijo "Dynamic Crisp". Krožnik Crisp je treba vedno postaviti na sredino steklenega vrtljivega krožnika. Lahko se predgreje prazen s posebno

funkcijo, ki je namenjena le za to uporabo. Položite hrano neposredno na krožnik Crisp.

## ROČAJ ZA KROŽNIK CRISP

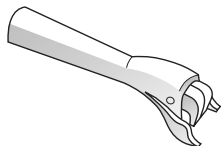

Uporabno za odstranjevanje vročega krožnika Crisp iz pečice.

## PRAVOKOTNI PEKAČ

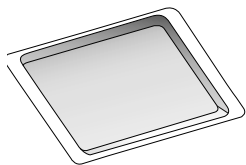

Uporabljajte le pekač s funkcijami, ki omogočajo konvekcijsko pečenje; nikoli ga ne uporabljajte v kombinaciji z mikrovalovi. Krožnik postavite vodoravno na vodilo v notranjosti pečice.

Opomba: Za uporabo pravokotnega pekača vam ni treba odstraniti vrtljivega krožnika in njegovega podstavka.

## NIZKA REŠETKA

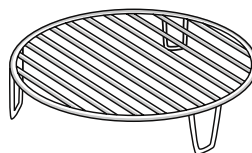

Omogoča, da hrano položite bližje žara, za popolno zapečene jedi in optimalno kroženje toplega zraka. Položite rešetko na vrtljivi krožnik in se prepričajte, da se med vrtenjem ne dotika

drugih površin.

## UPARJALNIK

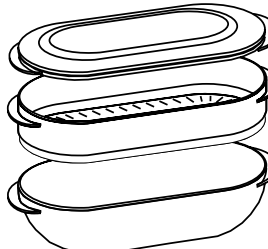

1 Za kuhanje na pari živila, kot so ribe ali zelenjava, položite v košarico (2) in natočite pitno vodo (100 ml) na dno parnega pekača (3), da se ustvari ustrezna količina pare.

Za kuhanje živil, kot so testenine, riž ali krompir, ta položite neposredno na dno parnega pekača (košarica ni potrebna) in dodajte ustrezno količino pitne vode glede na količino živil.

Za boljše rezultate parni pekač pokrijte s priloženim pokrovom (1).

Parni pekač vedno položite na stekleni vrtljivi krožnik in ga uporabljajte le z ustreznimi funkcijami pečice oziroma mikrovalovne pečice.

## POKROV

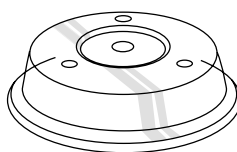

Uporabno za pokrivanje hrane med pripravo hrane ali pogrevanjem v mikrovalovni pečici.

Zaradi pokrova nastane manj madežev, hrana se ne izsuši,

možna pa je tudi priprava hrane na dveh ravneh. Ni primeren za konvekcijsko pečenje ali uporabo s katero koli funkcijo žara (vključno z "Dynamic Crisp").

Opomba: Število dodatkov se lahko razlikuje glede na kupljeni model. Druge kose pribora je mogoče naknadno kupiti pri servisni službi.

**Na tržišču je velik izbor raznega pribora. Pred nakupom pribora se prepričajte, da je ta primeren za uporabo v mikrovalovni pečici in odporen na temperature v pečici.**

**Pri uporabi mikrovalov se ne smejo nikoli uporabljati kovinske posode za hrano ali pijačo.**

**Vedno zagotovite, da hrana in pribor ne prideta v stik z notranjimi stenami pečice.**

**Pred zagonom pečice se vedno prepričajte, da se vrtljiva plošča ne vrti brez oviranja. Pazite, da pri vstavljanju ali odstranjevanju pribora ne premaknete vrtljivega krožnika z njegovega postavka.**

# FUNKCIJE



Prenesite Navodila za uporabo in vzdrževanje s spletne strani [docs.hotpoint.eu](http://docs.hotpoint.eu) za dodatne informacije.



## MANUAL (ROČNO)

### MICROWAVE (MIKROVALOVNA)

Za hitro pripravo in pogrevanje hrane in pijače.

MOČ	PRIPOROČENA UPORABA
900 W	Hitro pogrevanje pijač in jedl z veliko vsebnostjo vode
750 W	Kuhanje zelenjave
650 W	Priprava mesa in rib
500 W	Priprava mesnih omak in omak, ki vsebujejo jajca ali sir. Zaključna faza pečenja mesnih pit in lasanj
350 W	Počasna, nežna priprava. Popolno za topljenje masla ali čokolade
160 W	Odmrzovanje zamrznjenih jedi ali mehčanje masla ali sira
90 W	Mehčanje sladoleda

Priporočeni pribor: Pokrov



### DYNAMIC CRISP

Za popolno zapečene jedi, tako na vrhnji kot na spodnji strani. To funkcijo uporabljajte le s posebnim krožnikom Crisp.

Potreben pribor: Krožnik Crisp, ročaj za krožnik Crisp



### GRILL (ŽAR)

Za površinsko pečenje, peko na žaru in gratiniranje. Priporočamo, da hrano med pripravo obrnete. Za najboljše rezultate žar predgrevajte 3–5 minut.

Priporočeni pribor: rešetka



### GRILL + MICROWAVE (ŽAR + MIKROVALOVNA)

Za hitro pripravo hrane in gratiniranje jedi, kombinacijo funkcij mikrovalovne pečice in žara.

Priporočeni pribor: rešetka



### TURBO GRILL (HITRI ŽAR)

Za popolne rezultate s kombinacijo funkcij žara in konvekcijskega pečenja. Priporočamo, da živila med pripravo obrnete.

Priporočeni pribor: rešetka



### TURBO GRILL + MICROWAVE (HITRI ŽAR + MIKROVALOVNA)

Za hitro pripravo hrane in površinsko pečenje jedi, s kombinacijo funkcij mikrovalovne pečice, žara in konvekcijske pečice.

Priporočeni pribor: rešetka



### FORCED AIR (TERMOVENTILACIJSKA PRIPRAVA)

Za pripravo jedi s podobnim rezultatom kot v običajni pečici.

Za pripravo določenih jedi lahko uporabite pekač ali drugo posodo, ki je primerna za uporabo v pečici.

Priporočeni pribor: Pravokotni pekač/rešetka



### FORCED AIR + MICROWAVE (TERMOVENTILACIJSKA PRIPRAVA + MIKROVALOVNA)

Za hitro pripravo jedi v pečici.

Priporočeni pribor: rešetka



### QUICK HEAT (HITRO OGREVANJE)

Za hitro predgrevanje pečice pred začetkom priprave hrane.

Počakajte, da funkcija neha delovati, preden v pečico položite hrano.



### SENSOR (TIPALO)

Funkcije tipala se med pripravo hrane nenehno prilagajajo, kar omogoča doseganje izjemnih rezultatov.

Skupni čas ne vključuje faz priprave in predgrevanja.



### DYNAMIC REHEAT

Za pogrevanje že pripravljenih jedi, in sicer zamrznjenih ali sobne temperature.

Pečica samodejno izračuna vrednosti, ki so potrebne za doseganje najboljših rezultatov v najkrajšem času. Jed položite na toploto odporen krožnik ali posodo, primerno za mikrovalovno pečico



### DYNAMIC CRISP

Za hitro pogrevanje in pripravo zamrznjenih jedi, za zapečeno in hrustljivo skorjo. To funkcijo uporabljajte le s priloženim krožnikom Crisp.

Potreben pribor: Krožnik Crisp, ročaj za krožnik Crisp



### DYNAMIC STEAM

Za kuhanje živil, kot so ribe in zelenjava, na pari s priloženim parnim pekačem.

V fazi priprave se samodejno ustvari para in voda, natočena na dno parnega pekača, začne vreti. Ta faza lahko traja različno dolgo časa. Pečica nato nadaljuje s pripravo hrane na pari skladno z nastavljenim časom.

Nekaj okvirnih časov priprave hrane:

- sveža zelenjava (250–500 g): 4–6 minut;
- zamrznjena zelenjava (250–500 g): 5–7 minut;
- ribji fileji (250–500 g): 4–6 minut.

Potreben pribor: Uparjalnik



## KEEP WARM (OHRANJANJE JEDI TOPLIH)

Za ohranjanje pravkar pripravljene hrane vroče in hrustljave, vključno z mesom, ocvrto hrano in tortami).

## AUTO AUTOMATIC (SAMODEJNO)

Pri samodejnih funkcijah preprosto izberite težo ali količino živil za doseganje najboljših možnih rezultatov.



### DYNAMIC DEFROST

Za hitro odmrzovanje mesa, perutnine, rib, zelenjave in kruha, ki tehta med 100 g in 3 kg. Hrano položite neposredno na steklen vrtljiv krožnik.



### CRISPY BREAD DEFROST (ODMRZOVANJE HRUSTLJAVEGA KRUHA)

Za hitro odmrzovanje in pogrevanje štručk, rogljičev in baget. Pečica samodejno izračuna vrednosti, ki so potrebne za doseganje najboljših rezultatov (čas, moč in način priprave).

Potreben pribor: Krožnik Crisp, ročaj za krožnik Crisp



### RECIPES (RECEPTI)

Tako lahko izbirate med vrsto samodejnih receptov s prednastavljenimi vrednostmi za optimalno pripravo. Za najboljše rezultate upoštevajte navodila na zaslonu.

Opomba: za več informacij, receptov in koristnih nasvetov glede uporabe funkcije prenesite in preberite Navodila za uporabo in vzdrževanje, ki so vam na voljo na spletni strani [docs.hotpoint.eu](http://docs.hotpoint.eu).



## SETTINGS (NASTAVITVE)

Za spreminjanje nastavitev pečice (jezik, čas, glasnost zvočnih signalov, osvetlitev Eco).

Opomba: ko je način Eco vključen, se svetlost zaslona po nekaj sekundah zmanjša, da aparat tako varčuje z energijo. Zaslون se samodejno vključi vedno, ko pritisnete na katero koli tipko itd.

# PRED PRVO UPORABO PEČICE

## 1. IZBERITE JEZIK

Ko napravo prvič vključite, morate nastaviti jezik in čas. na zaslonu se prikaže seznam razpoložljivih jezikov.

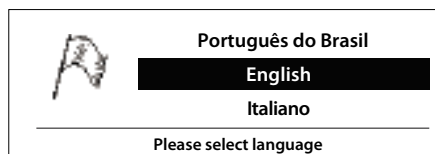

Pritisnite ali , da izberete zeleni jezik, in nato , da izbiro potrdite.

Opomba: jezik lahko v menijski točki "Nastavitve" spremenite tudi naknadno.

## 2. NASTAVITEV ČASA

Po izbiri jezika morate nastaviti še trenutni čas: na zaslonu utripa 12:00.

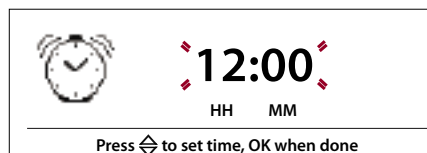

Za nastavitve časa pritisnite ali in za potrditev .

Opomba: po daljšem izpadu električnega toka boste morali čas mogoče znova nastaviti.

# VSAKODNEVNA UPORABA

## 1. IZBIRA FUNKCIJE

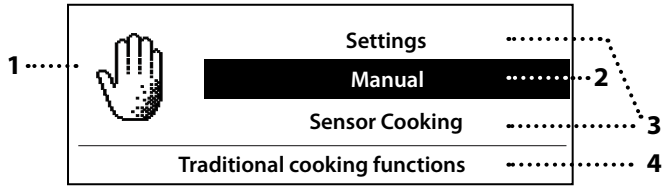

1. Simbol za izbrano funkcijo
2. Izbrana funkcija
3. Druge razpoložljive funkcije
4. Opis izbrane funkcije

### VKLOP PEČICE

Pritisnite : na zaslonu se pojavi glavni meni.

### POMIKANJE PO MENIJU

Pritisnite ali za pomikanje po meniju in označite element, ki ga želite izbrati.

### IZBIRA MENIJSKE TOČKE

Ko na zaslonu označite želeni element, za potrditev pritisnite in se pomaknite v meni za nastavitve (glej spodaj) oz. seznam funkcij.

### IZBIRA FUNKCIJE

Za pomikanje po danem seznamu pritisnite ali . Za potrditev in pomik v meni z nastavitvami pritisnite .

## 2. NASTAVITEV IN VKLOP FUNKCIJE

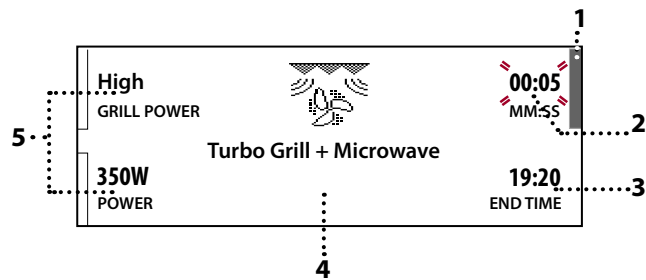

1. Izberite kazalec (označi izbrano nastavitev)
2. Trajanje
3. Čas konca funkcije
4. Poimenovanje funkcije
5. Nastavitve funkcije (moč, temperatura, stopnja žara, teža ali količina, zelena stopnja pečenosti itd.)

### UPORABA NASTAVITEV

Na začetku je mogoče nastaviti vrednosti izbrane funkcije s števkami na zaslonu. Ko vrednost utripa, za nastavitve vrednosti uporabite ali in pritisnite za potrditev.

Po potrebi uporabite ali , da se s kazalcem premaknete na naslednjo vrednost, ki jo želite spremeniti, in pritisnite . Vrednost bo utripala.

Za spremembo vrednosti uporabite ali in za potrditev pritisnite .

### VKLOP FUNKCIJE

Ko se na zaslonu prikažejo zelene nastavitve, pritisnite , da vklopite funkcijo.

Opomba: V nekaterih primerih je nekatere vrednosti mogoče spreminjati tudi med pripravo hrane.

## . VARNOSTNI ZAKLEP

Ta funkcija se samodejno vklopi, da pečice ni mogoče nehote vključiti.



Odprite in zaprite vrata ter nato pritisnite za začetek izvajanja izbrane funkcije.

## . PREMOR

Za premor aktivne funkcije, na primer, da pomešate ali obrnete jed, preprosto odprite vrata.



Za vnovičen zagon funkcije zaprite vrata in pritisnite .

## . JET START





Ko je pečica izklopljena, pritisnite za vklop priprave hrane s funkcijo mikrovalov pri polni moči (900 W) za 30 sekund.

Z vsakim vnovičnim pritiskom tipke se čas priprave podaljša za 30 sekund.

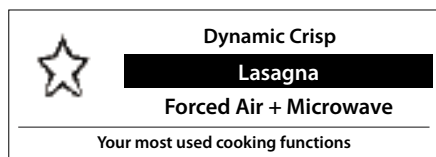
## . PRILJUBLJENE

Aparat samodejno sestavi seznam najpogosteje uporabljenih funkcij. Pritisnite tipko , da vključite pečico. Nato pritisnite , da prikličete seznam najpogosteje uporabljenih funkcij.



Za izbiro zelene funkcije izberite  ali , za potrditev pritisnite  in nato po potrebi spremenite nastavitve glede na svoje potrebe (predlagane nastavitve so splošne). Pritisnite , da vključite funkcijo.

## . PREOSTALA TOPLOTA

V mnogih primerih po tem, ko je hrana že pripravljena, pečica samodejno sproži postopek hlajenja, kar je označeno tudi na zaslonu.

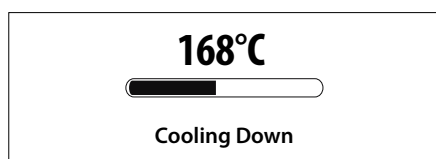





Za pogled na uro med tem postopkom pritisnite .

Opomba: Z odpiranjem vrat se postopek začasno prekine.

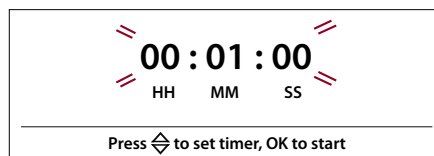
## . MERILEC ČASA

Ko je pečica izključena, lahko zaslon uporabite kot časovnik. Za vklop funkcije pritisnite . Na zaslonu se prikaže časovnik.





Pritisnite  ali  za nastavev želenega časa trajanja in nato pritisnite  za vklop časovnika. Ko se nastavljen čas izteče, se zasliši zvočni signal.











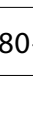

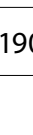







Opomba: Časovnik ne aktivira nobenega postopka priprave hrane.

Za zaustavitev časovnika v katerem koli trenutku pritisnite .

## . ZAKLEP TIPK

Za zaklep tipk vsaj pet sekund istočasno držite  in . Za vklop tipk postopek ponovite.

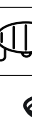
# PREGLEDNICA ZA PRIPRAVO HRANE

JED	FUNKCIJA	PREDGREVANJE	TEMP. (°C)/ STOPNJA ŽARA	MOČ (W)	TRAJANJE	PRIBOR
<b>Biskvitne torte</b>		-	160-180	-	30-60	
		-	160-180	90	25-50	
<b>Pite z nadevom</b> (skutna pita, jabolčni zavitek, jabolčna pita)		Da	160-190	-	35-70	
<b>Piškoti</b>		Da	170-180	-	10-20	
<b>Beljakovi poljubčki</b>		Da	100-120	-	40-50	
<b>Štručke</b>		Da	210-220	-	10-12	
<b>Štruca kruha</b>		Da	180-200	-	30-35	
<b>Pica/pita</b>		Da	190-220	-	20-40	
<b>Pica</b> (0,4-0,5 kg)		-	-	-	14-16	
<b>Slane pite</b> (zelenjavna pita, lotarinška pita)		Da	180-190	-	40-55	
<b>Lotarinška pita</b> (1-1,2 kg)		-	-	-	18-20	

JED	FUNKCIJA	PREDGREVANJE	TEMP. (°C)/ STOPNJA ŽARA	MOČ (W)	TRAJANJE	PRIBOR
<b>Lazanja/pečene testenine</b>			Srednje kuhana	350-500	15-40	
<b>Jagnječja/telečja/goveja pečenka</b> (1,3–1,5 kg)		-	170-180	-	70–80*	
		-	160–180	160	50–70*	
<b>Goveja pečenka – srednje pečena</b> (1,3–1,5 kg)		-	170–180	-	40–60*	
<b>Pečen piščanec/kunec/raca</b> (cel, 1–1,2 kg)		-	210-220	-	50–70*	
		-	210–220	350	45–60*	
<b>Piščanec/kunec/raca</b> (fileji/koščki)		-	Srednje visoko	350–500	20–40*	
<b>Kosi piščanca</b> (0,4–1 kg)		-	-	-	12–18	
<b>Cela pečena riba</b> (cela)		-	Visoka	160-350	20-40	
<b>Ribji fileji/kosi</b>		Da	Visoka	-	15–30*	
<b>Polnjena zelenjava</b> (paradižnik, bučke, jajčevci)		-	Srednje kuhana	500–650	25-50	
<b>Toast</b>		-	Visoka	-	3-6	
<b>Klobase/kebab/rebrca/hamburgerji</b>		-	Srednje visoko	-	20–40*	
<b>Klobase/burgerji</b> (0,2–1 kg)		Da**	-	-	6–16	
<b>Pečen krompir</b>		-	Srednje kuhana	350–500	20–40*	
<b>Krompir v krhljih</b> (0,3–0,8 kg)		-	-	-	10-20	
<b>Pečeno sadje</b>		-	Srednje kuhana	160-350	15-25	
<b>Gratinirana zelenjava</b>		-	Srednje visoko	-	15–25	
<b>Ocvrta zelenjava</b> (0,3–0,8 kg)		Da**	-	-	8–18	

\* Na polovici priprave hrano obrnite

\*\* Predgrejte krožnik Crisp 3–5 minut

[www](http://www.docs.hotpoint.eu) Za več informacij, receptov in koristnih nasvetov glede uporabe samodejnih funkcij prenesite in preberite Navodila za uporabo in vzdrževanje, ki so vam na voljo na spletni strani **docs.hotpoint.eu**

[www](http://www.docs.hotpoint.eu) Za preglednico preizkušenih receptov, ki je bila sestavljena za certifikacijske organe v skladu s standardoma IEC 60705 in IEC 60350, prenesite Navodila za uporabo in vzdrževanje s spletne strani **docs.hotpoint.eu**

FUNKCIJE	Crisp	Grill (Žar)	Grill + Microwave (Žar + Mikrovalovna)	Turbo Grill (Hitri žar)	Forced Air (Termoventilacijska priprava)	Forced Air + Microwave (Termoventilacijska priprava + Mikrovalovna)
PRIBOR	Krožnik, odporen na vročino / posoda, primerna za mikrovalovno pečico 	Nizka rešetka 		Krožnik Crisp 		Pravokotni pekač 

# ČIŠČENJE

**Pred vzdrževanjem ali čiščenjem se prepričajte, da se je aparat ohladil.**

**Ne uporabljajte parnih čistilnikov.**

**Ne uporabljajte jeklenih gob, abrazivnih čistilnih gob ali abrazivnih/korozivnih čistilnih sredstev, saj bi ti lahko poškodovali površine aparata.**

## NOTRANJE IN ZUNANJE POVRŠINE

- Površine čistite z vlažno krpo iz mikrovlaknen. Če so površine zelo umazane, dodajte v vodo nekaj kapljic pH nevtralnega sredstva za pomivanje posode. Na koncu površine obrišite s suho krpo.
- Steklo na vratih očistite z ustreznim tekočim čistilnim sredstvom.
- V rednih časovnih intervalih ali, če pride do razlivanja, odstranite vrtljiv krožnik in podstavek ter očistite dno pečice ter odstranite vse ostanke hrane.
- Žara ni treba čistiti, saj umazanija zgori od vročine. To funkcijo redno uporabljajte.

## PRIBOR

- Ves pribor je primeren za pomivanje v pomivalnem stroju, razen krožnika Crisp..
- Krožnik Crisp je treba očistiti z vodo in blagim sredstvom za pomivanje. Trdovratno umazanijo nežno podrgnite s krpo. Pred čiščenjem vedno počakajte, da se krožnik Crisp ohladi.

## ODPRAVLJANJE TEŽAV



Prenesite Navodila za uporabo in vzdrževanje s spletne strani **docs.hotpoint.eu** za dodatne informacije.

Motnja	Možen vzrok	Rešitev
Pečica ne deluje.	Izpad električne energije. Prekinitev napajanja.	Preverite, ali je v vtičnici električni tok in ali je pečica priklopljena na električno napajanje. Z izklopom in ponovnim vklopom pečice preverite, ali je napaka še vedno prisotna.
Ta pečica spušča zvoke, celo ko je izključena.	Ventilator za ohlajanje deluje.	Odprite vrata ali počakajte, da se postopek hlajenja zaključi.
Na zaslonu je prikazana črka "F", ki ji sledi številka.	Napaka programske opreme.	Obrnite se na najbližjo servisno službo in navedite številko, ki sledi črki "F".

## PODATKOVNA KARTICA IZDELKA

Podatkovno kartico izdelka skupaj s podatki o energiji za ta aparat lahko prenesete s spletne strani **docs.hotpoint.eu**.

## KAKO DO NAVODIL ZA UPORABO IN VZDRŽEVANJE

> Z naše spletne strani **docs.hotpoint.eu** prenesite Navodila za uporabo in vzdrževanje (uporabite lahko to kodo QR), pri čemer vnesite prodajno kodo izdelka.

> Lahko se obrnete tudi na našo servisno službo.



## KADAR SE OBRNETE NA NAŠO SERVISNO SLUŽBO ...

Naši kontaktni podatki so v garancijski knjižici. Ko stopite v stik z našo servisno službo, navedite kodo, ki so zapisane na identifikacijski ploščici izdelka.

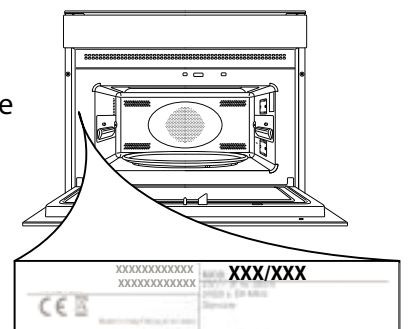



# VODIČ ZA SVAKODNEVNU UPOTREBU



## HVALA NA KUPOVINI HOTPOINT - ARISTON PROIZVODA

Da biste dobili sveobuhvatnu pomoć i podršku, molimo vas da registrujete svoj proizvod na web stranici [www.hotpoint.eu/register](http://www.hotpoint.eu/register)



Bezbednosna uputstva, kao i uputstvo za upotrebu i održavanje možete preuzeti na našoj web lokaciji [docs.hotpoint.eu](http://docs.hotpoint.eu) prateći uputstva sa poleđine ove brošure.



**Pre upotrebe uređaja, pažljivo pročitajte bezbednosna uputstva.**

## OPIS PROIZVODA

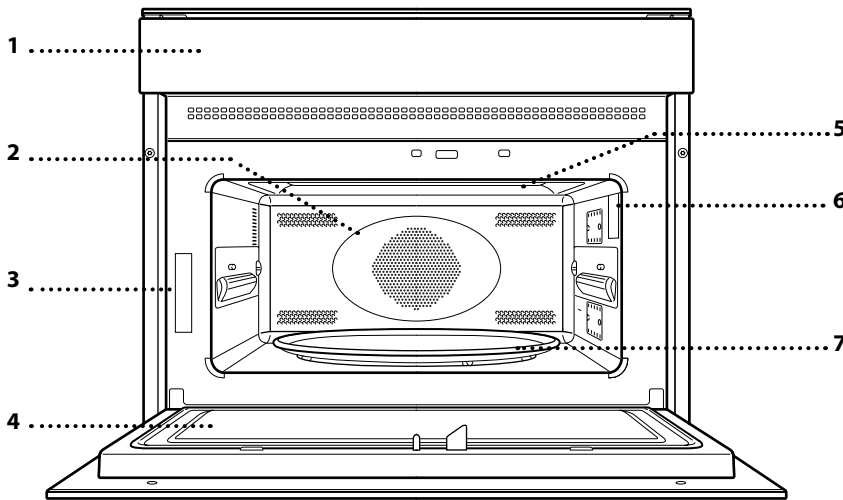

1. Komandna tabla
2. Kružni grejač (nije vidljiv)
3. Pločica za identifikaciju (nemojte je uklanjati)
4. Vrata
5. Gornji grejač/roštilj
6. Svetlo
7. Obrtna ploča

## KONTROLNA TABLA

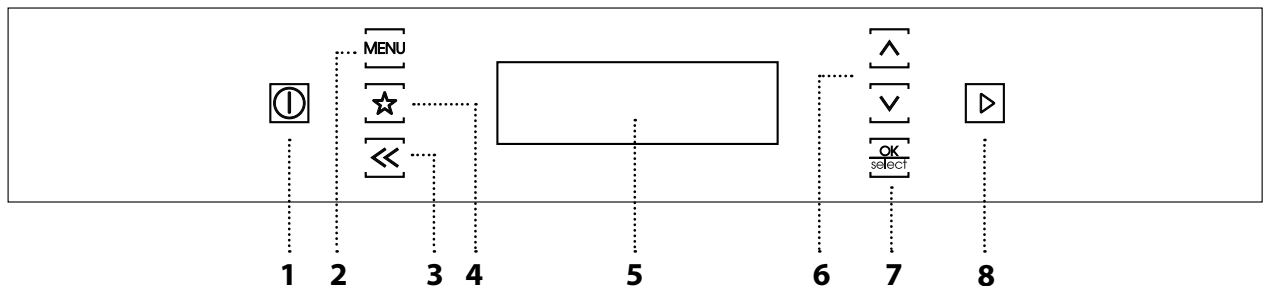

### 1. UKLJUČIVANJE I ISKLJUČIVANJE

Za uključivanje i isključivanje rerne ili za pauziranje ili prekid rada.

### 2. MENI

Za pristupanje listi funkcija.

### 3. NAZAD

Za povratak na prethodni meni.

### 4. OMILJENO

Za pristupanje listi funkcija koje se najviše koriste.

### 5. DISPLEJ

6. TASTERI ZA NAVIGACIJU  
Za pomeranje kroz listu funkcija, pomeranje kursora i promenu podešavanja funkcije.

### 7. TASTER ZA POTVRDU

Za potvrdu odabira funkcije ili postavljene vrednosti.

### 8. START

Za trenutno pokretanje funkcije. Kada je pećnica isključena, aktivira se funkcija „**Jet Start**“ mikrotalasne pećnice.

## OBRTNA PLOČA

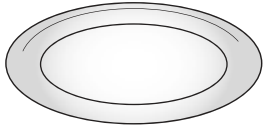

Kada je postavljena na svoje postolje, staklena obrtna ploča se može koristiti za sve načine pripreme hrane.

Obrtna ploča se uvek mora koristiti kao podloga za sve

druge posude ili pribor, osim za pravougaoni pleh za pečenje.

## NOSAČ OBRTNE PLOČE

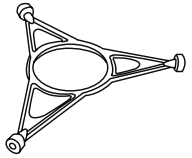

Nosač koristite samo za staklenu obrtnu ploču. Ne stavljajte drugi pribor na nosač.

## CRISP TANJIR

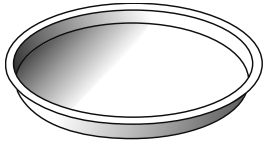

Koristite samo za posebnu funkciju „Dynamic Crisp”. Crisp tanjir se uvek mora postaviti na sredinu staklene obrtne ploče i može se prethodno zagrejati kada je

prazan, samo pomoću posebne funkcije za ovu svrhu. Stavite hranu direktno na tanjir za stvaranje hrskave korice.

## DRŠKA ZA CRISP TANJIR

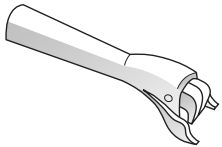

Korisna je pri uklanjanju crisp tanjira iz pećnice.

## PRAVOUGAONI PLEH ZA PEČENJE

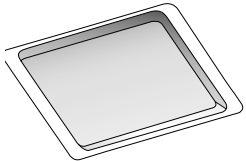

Pleh za pečenje koristite samo sa funkcijama koje dozvoljavaju konvekciono kuvanje; nikada se ne sme koristiti u kombinaciji sa mikrotalasima. Tanjir ubacite horizontalno, stavljajući ga na

rešetku u delu za pečenje.

Molimo vas obratite pažnju na sledeće: Ne morate uklanjati obrtnu ploču i nosač pri korišćenju pravougaonog pleha za pečenje.

Molimo vas obratite pažnju na sledeće: Broj komada pribora može da se razlikuje u zavisnosti od kupljenog modela. Ostali pribor može odvojeno da se nabavi kod službe za korisnike.

**Na tržištu je dostupan razni pribor. Pre nego što kupite neki, uverite se da je pogodan za upotrebu u mikrotalasnoj pećnici i otporan na temperaturu rerne.**

**Metalne posude za hranu ili piće ne treba nikada koristiti za kuvanje u mikrotalasnoj pećnici.**

## DONJA REŠETKA

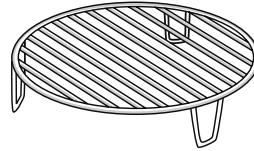

Omogućava vam da hranu stavite bliže roštilju, da savršeno zapečete hranu i optimalnu cirkulaciju vrelog vazduha. Postavite rešetku na obrtnu ploču, vodeći računa da ne dođe

u kontakt sa drugim površinama.

## POSUDA ZA KUVANJE NA PARI

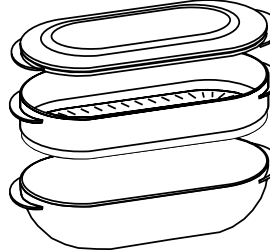

1 Za kuvanje na pari hrane kao što je riba ili povrće, stavite je u korpu (2) i sipajte vodu za piće (100 ml) na dno posude za kuvanje na pari (3) kako biste dobili potrebnu količinu pare.

Za barenje hrane kao što je pasta, pirinač ili krompir, stavite je na dno posude za kuvanje na pari (korpa nije neophodna) i dodajte vodu za piće u količini koja odgovara količini hrane koju kuvate.

Za najbolje rezultate, pokrijte posudu za kuvanje na pari dostavljenim poklopcem (1). Posudu za kuvanje na pari uvek stavljajte na staklenu obrtnu ploču i koristite je samo sa odgovarajućim funkcijama za pripremu hrane ili sa funkcijama mikrotalasa.

## POKLOPAC

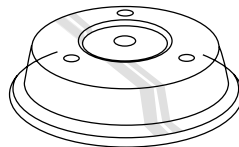

Koristan za pokrivanje hrane dok se kuva ili zagreva u mikrotalasnoj pećnici.

Poklopac smanjuje prskanje, održava vlažnost hrane, a takođe se može koristiti i za stvaranje dva

nivoa kuvanja.

Nije podesan za korišćenje pri tradicionalnom kuvanju ili uz bilo koju od funkcija roštilja (uključujući „Dynamic Crisp”).

**MANUAL (PRIRUČNIK)****MICROWAVE (MIKROTALASNA PEĆNICA)**

Za brzo kuvanje ili zagrevanje hrane ili pića.

SNAGA	PREDLOŽENA UPOTREBA
<b>900 W</b>	Brzo zagrevanje pića ili hrane sa visokim sadržajem vode
<b>750 W</b>	Kuvanje povrća
<b>650 W</b>	Pripremanje mesa i ribe
<b>500 W</b>	Kuvanje soseva za meso ili soseva sa sirom ili jajima. Da se zapeku pite sa mesom ili pasta
<b>350 W</b>	Sporo, lagano kuvanje. Idealno za otapanje putera ili čokolade
<b>160 W</b>	Odmrzavanje zaleđene hrane ili omekšavanje putera ili sira
<b>90 W</b>	Omekšavanje sladoleda

Preporučeni pribor: Poklopite

**DYNAMIC CRISP**

Da se hrana savršeno zapeče i sa donje i sa gornje strane. Ova funkcija se može koristiti samo uz poseban crisp tanjir.

Potreban pribor: Crisp tanjir, drška za crisp tanjir

**GRILL (ROŠTILJ)**

Da se hrana zapeče, pripremi na roštilju ili gratinira. Preporučujemo da hranu okrenete tokom kuvanja. Za najbolje rezultate, prethodno zagrejte roštilj 3-5 minuta.

Preporučeni pribor: rešetka

**GRILL + MICROWAVE (ROŠTILJ + MIKROTALASI)**

Za brzo kuvanje i gratiniranje hrane, uz kombinaciju funkcija roštilja i mikrotalasa.

Preporučeni pribor: rešetka

**TURBO GRILL (TURBO ROŠTILJ)**

Za svršene rezultate, uz kombinaciju funkcija roštilja i konvektionog kuvanja. Preporučujemo da hranu okrenete tokom kuvanja.

Preporučeni pribor: rešetka

**TURBO GRILL + MICROWAVE (TURBO ROŠTILJ + MIKROTALASI)**

Da brzo skuvate ili zapečete hranu, uz kombinaciju funkcija mikrotalasa, roštilja i konvektionog kuvanja.

Preporučeni pribor: rešetka

**FORCED AIR (VRELI VAZDUH)**

Za pečenje obroka na način kojim se postižu slični rezultati kao i prilikom korišćenja klasične rerne.

Pleh za pečenje ili drugo posuđe podesno za upotrebu u rerni može da se koristi za pečenje određene hrane.

Preporučeni pribor: Pravougaoni pleh za pečenje/rešetka

**FORCED AIR + MICROWAVE (VRELI VAZDUH + MIKROTALASI)**

Za pripremanje hrane u rerni za kratko vreme.

Preporučeni pribor: rešetka

**QUICK HEAT (BRZO ZAGREVANJE)**

Za brzo zagrevanje rerne pre procesa kuvanja. Sačekajte da se ova funkcija završi pre nego što stavite hranu u rernu.

**SENSOR (SENZOR)**

Funkcije senzora se kontinuirano prilagođavaju tokom kuvanja, što vam omogućava da postignete odlične rezultate. Ukupno vreme ne uključuje faze pripreme ili predzagrevanja.

**DYNAMIC REHEAT**

Za podgrevanje gotove hrane koja je ili zaleđena ili na sobnoj temperaturi.

Pećnica automatski izračunava vrednosti potrebne za postizanje najboljih mogućih rezultata za najkraće vreme. Stavite hranu na tanjir ili posudu bezbednu za mikrotalasnu upotrebu i otpornu na toplotu.

**DYNAMIC CRISP**

Za brzo podgrevanje i kuvanje zaleđene hrane, za postizanje zlatne boje i hrskavosti. Uz ovu funkciju upotrebljavajte samo priloženi crisp tanjir.

Potreban pribor: Crisp tanjir, drška za crisp tanjir

**DYNAMIC STEAM**

Za kuvanje hrane na pari, kao što je povrće ili riba, koristite dostavljenu posudu za kuvanje na pari. Faza pripreme automatski generiše paru, tako što vodu na dnu posude za kuvanje na pari dovodi do ključanja. Vreme pripreme u ovoj fazi može da varira. Pećnica zatim nastavlja da priprema hranu na pari u skladu sa podešenim vremenom.

Preporučeno vreme kuvanja nekih namirnica je sledeće:

- sveže povrće (250 - 500 g): 4 - 6 minuta;
- zamrznuto povrće (250 - 500 g): 5 - 7 minuta;
- fileti ribe (250 - 500 g): 4 - 6 minuta.

Potreban pribor: Posuda za kuvanje na pari



## KEEP WARM (ODRŽAVANJE TOPLOTE)

Koristi se za održavanje tek spremljene hrane toplom i svežom, uključujući meso, prženu hranu ili kolače.

## AUTO AUTOMATIC (AUTOMATSKI)

Uz automatske funkcije, jednostavno odaberite težinu ili količinu hrane za postizanje najboljih mogućih rezultata.



### DYNAMIC DEFROST

Za brzo odmrzavanje mesa, živine, ribe, povrća i hleba težine između 100 g i 3 kg. Hranu treba staviti direktno na staklenu obrtnu ploču.



### CRISPY BREAD DEFROST (ODMRZAVANJE HRŠKAVOG HLEBA)

Za brzo odmrzavanje i podgrevanje kifli, kroasana i bageta. Pećnica automatski izračunava vrednosti potrebne za postizanje najboljih mogućih rezultata (vreme, jačinu i način kuvanja).

Potrebni pribor: Crisp tanjir, drška za crisp tanjir



### RECIPES (RECEPTI)

**AUTO** Ovo vam omogućava da birate između različitih automatski recepata sa prethodno podešenim vrednostima za optimalno kuvanje. Za najbolje rezultate, sledite uputstva prikazana na displeju.

Obratite pažnju na sledeće: Za dodatne informacije, recepte i korisne savete za korišćenje ove funkcije, pročitajte i preuzmite Uputstvo za upotrebu i održavanje na [docs.hotpoint.eu](http://docs.hotpoint.eu)



## SETTINGS (PODEŠAVANJA)

Za promenu podešavanja pećnice (jezika, vremena, jačine zvučnog signala, osvetljenja, Eco režima).



Molimo Vas obratite pažnju na sledeće: Kada je aktiviran Eko režim, osvetljenost displeja će se smanjiti nakon nekoliko sekundi radi uštede energije. Displej se automatski ponovo aktivira kada se pritisnete bilo koji taster, itd.

# PRVA UPOTREBA UREĐAJA

## 1. MOLIMO ODABERITE JEZIK

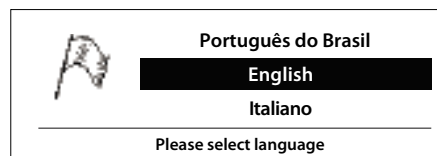
Treba da podesite jezik i vreme prilikom prvog uključivanja uređaja. Na ekranu će se prikazati lista dostupnih jezika.





Koristite  ili  da biste izabrali jezik koji želite i pritisnite  za potvrdu.

Molimo vas obratite pažnju na sledeće: Jezik se takođe može i kasnije menjati preko opcije „Podešavanja” na meniju.

## 2. PODESITE VREME

Nakon što ste izabrali jezik, treba da podesite trenutno vreme: 12:00 se pojavljuje na ekranu.



Koristite  ili  da podesite vreme i pritisnite  za potvrdu.

Molimo vas obratite pažnju na sledeće: Možda ćete morati ponovo da podesite vreme nakon dužih nestanaka struje.

# SVAKODNEVNA UPOTREBA

## 1. IZABERITE FUNKCIJU

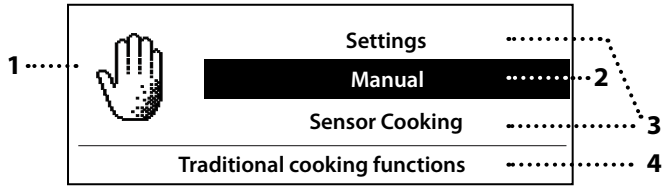

1. Simbol za izabranu funkciju
2. Izabrana funkcija
3. Ostale dostupne funkcije
4. Opis izabrane funkcije

### UKLJUČITE RERNU

Pritisnite : Na displeju će se prikazati glavni meni.

### PRETRAŽITE MENI

Pritisnite ili da biste pretražili glavni meni i obeležite stavku koju želite da odaberete.

### IZABERITE STAVKU IZ MENIJA

Kada je stavka koju želite da izaberete obeležena na displeju, pritisnite za potvrdu i pređite na meni za podešavanja (pogledajte u nastavku) ili na listu funkcija.

### IZABERITE FUNKCIJU

pritisnite ili da pretražite datu listu. Pritisnite za potvrdu i pređite na meni za podešavanja.

## 2. PODEŠAVANJE I AKTIVIRANJE FUNKCIJE

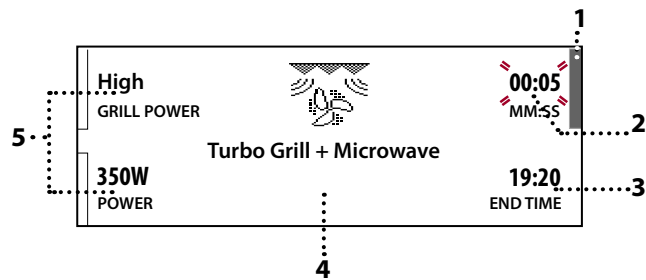

1. Kursor za biranje (obeležava odabranu funkciju)
2. Trajanje
3. Vreme u koje će se funkcija završiti
4. Naziv funkcije
5. Podešavanja za funkciju (jačina, temperatura, nivo roštilja, težina ili količina, željeni stepen kuvanja, i tako dalje)

### PRIMENI PODEŠAVANJA

Prvo, moguće je podesiti vrednosti izabrane funkcije na osnovu postupka prikazanog na displeju. Kada vreme zasvetli, koristite ili da podesite vrednost i pritisnite za potvrdu.

Ukoliko je potrebno, koristite ili da pomerite kursor na vrednost koju želite da promenite i pritisnite . Ta vrednost će zasvetleti.

Koristite ili da promenite vrednost i pritisnite za potvrdu.

### AKTIVIRANJE FUNKCIJE

Kada vaša željena podešavanja budu prikazana, pritisnite da biste aktivirali funkciju.

Molimo vas obratite pažnju na sledeće: Tamo gde je moguće, neke vrednosti se čak mogu promeniti tokom kuvanja.

## . SIGURNOSNO ZAKLJUČAVANJE

Ova funkcija se automatski aktivira kako bi se sprečilo slučajno uključivanje pećnice.



Otvorite i zatvorite vrata, a zatim pritisnite da pokrenete odabranu funkciju.

## . PAUZA

Da pauzirate aktivnu funkciju, na primer kako biste promešali ili okrenuli hranu, jednostavno otvorite vrata.

Za ponovo pokretanje, zatvorite vrata i pritisnite .

## . JET START

Kada je pećnica isključena, pritisnite da aktivirate pripremu hrane uz funkciju mikrotalasa koja je podešena na punu jačinu (900 W) za 30 sekundi.

Svaki put kada se taster ponovo pritisne, vreme pripreme hrane će se produžiti za dodatnih 30 sekundi.

## . OMILJENO

Rerna će automatski sastaviti listu funkcija koje najviše koristite. Pritisnite taster ⓘ da biste uključili rernu, a zatim pritisnite ☆ da bi se prikazala lista funkcija koje najčešće koristite.

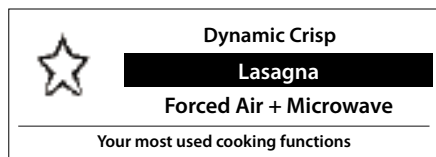

Koristite ▲ ili ▼ da izaberete željenu funkciju, pritisnite <sup>OK</sup>/<sub>select</sub> za potvrdu i zatim izmenite – ukoliko je potrebno – podešavanja u skladu sa svojim potrebama (preporučena su osnovna podešavanja). Kada bude gotovo, pritisnite ▶ za aktiviranje funkcije.

## . PREOSTALA TOPLOTA

U mnogo slučajeva, kada se kuva hrana, pećnica će aktivirati automatski proces hlađenja, što će biti prikazano na displeju.

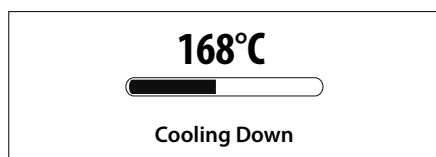

Da biste videli sat tokom ovog procesa, pritisnite <<.

Molimo vas obratite pažnju na sledeće: Otvaranje vrata privremeno prekida proces.

## . TAJMER

Kada je rerna isključena, displej se može koristiti kao tajmer. Da biste aktivirali funkciju, pritisnite <sup>OK</sup>/<sub>select</sub>. Tajmer će se prikazati na displeju.

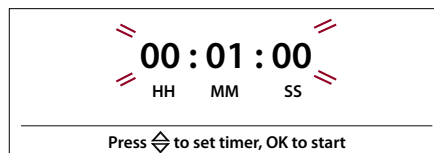

Pritisnite ▲ ili ▼ da podesite željeno trajanje, a zatim pritisnite <sup>OK</sup>/<sub>select</sub> da aktivirate tajmer. Oglasiće se zvučni signal kada tajmer završi sa odbrojanjem izabranog vremena.

Obratite pažnju na sledeće: Tajmer ne aktivira nijedan od procesa pripreme hrane. Da zaustavite tajmer u bilo kom trenutku, pritisnite ⓘ.

## . ZAKLJUČAVANJE TASTERA

Da biste zaključali tastaturu, istovremeno pritisnite i zadržite <sup>OK</sup>/<sub>select</sub> i << najmanje pet sekundi. Ovo ponovite da otključate tastaturu.

# TABELA PRIPREME JELA

HRANA	FUNKCIJA	PREDZAGREVANJE	TEMPERATURA (°C)/ NIVO ROŠTILJA	NAPAJANJE (W)	TRAJANJE	PRIBOR
Patišpanj		-	160-180	-	30-60	
		-	160-180	90	25-50	
Punjeni kolači (čizkejk, štrudla, pita sa jabukom)		Da	160-190	-	35-70	
Keks		Da	170-180	-	10-20	
Puslice		Da	100-120	-	40-50	
Zemičke		Da	210-220	-	10-12	
Vekna hleba		Da	180-200	-	30-35	
Pica / Pita		Da	190-220	-	20-40	
Pica (0,4-0,5 kg)		-	-	-	14-16	
Pikantne pite (pita od povrća, kiš-loren)		Da	180 - 190	-	40-55	
Kiš-loren (1-1,2 kg)		-	-	-	18-20	

HRANA	FUNKCIJA	PREDZAGREVANJE	TEMPERATURA (°C)/ NIVO ROŠTILJA	NAPAJANJE (W)	TRAJANJE	PRIBOR
<b>Lazanja/pečena testenina</b>			Srednja	350-500	15-40	
<b>Pečena jagnjetina/teletina/ pečena govedina</b> (1.3-1.5 kg)		-	170-180	-	70-80*	
		-	160-180	160	50-70*	
<b>Pečena govedina – srednje pečena</b> (1,3-1,5 kg)		-	170-180	-	40-60*	
<b>Pečeno pile/zec/patka</b> (cela 1-1.2 kg)		-	210-220	-	50-70*	
		-	210-220	350	45-60*	
<b>Piletina / Zečetina / Pačetina</b> (fileti / komadi)		-	Srednja–visoka	350-500	20-40*	
<b>Komadi piletine</b> (0,4 - 1 kg)		-	-	-	12-18	
<b>Pečena cela riba</b> (cela)		-	Visoka	160-350	20-40	
<b>Ribljí fileti/komadi</b>		Da	Visok	-	15-30*	
<b>Punjeno povrće</b> (paradajz, tikvice, plavi patlidžan)		-	Srednja	500-650	25-50	
<b>Tost</b>		-	Visok	-	3-6	
<b>Kobasice/ražnjići/ svinjska rebra/pljeskavice</b>		-	Srednja–visoka	-	20-40*	
<b>Kobasice/pljeskavice</b> (0,2 - 1 kg)		Da**	-	-	6-16	
<b>PEČENI KROMPIR</b>		-	Srednja	350-500	20-40*	
<b>Pečeni krompir u komadima</b> (0,3 - 0,8 kg)		-	-	-	10-20	
<b>Pečeno voće</b>		-	Srednja	160-350	15-25	
<b>Gratinirano povrće</b>		-	Visoka - srednja	-	15-25	
<b>Prženo povrće</b> (0,3-0,8 kg)		Da**	-	-	8-18	

\* Okrenite hranu na polovini pečenja

\*\* Prethodno zagrejte crisp tanjir 3 - 5 minuta

[www](http://www.docs.hotpoint.eu) Za dodatne informacije, recepte i korisne savete za korišćenje ove funkcije, pročitajte i preuzmite Uputstvo za upotrebu i održavanje na **docs.hotpoint.eu**

[www](http://www.docs.hotpoint.eu) Preuzmite Uputstvo za upotrebu i održavanje na web lokaciji **docs.hotpoint.eu** za listu isprobanih recepata, sastavljenih za nadležne organe za sertifikaciju u skladu sa standardima IEC 60705 i IEC 60350.

FUNKCIJE	Crisp (Crisp)	Grill (Roštilj)	Grill + Microwave (Roštilj + Mikrotalasi)	Turbo Grill (Turbogrill)	Forced Air (Vreli vazduh)	Forced Air + Microwave (Vreli vazduh + Mikrotalasi)
PRIBOR	Tanjir otporan na toplotu/posuda podesna za korišćenje u mikrotalasnim pećnicama		Donja rešetka	Crisp tanjir	Pravougaoni pleh za pečenje	

# ČIŠĆENJE

Obezbedite da se uređaj ohladio pre nego što započnete održavanje ili čišćenje.

Nemojte da koristite uređaje za čišćenje parom.

Ne koristite vunene žice, abrazivne sunde ili abrazivna/korozivna sredstva za čišćenje, jer oni mogu da oštete površinu uređaja.

## UNUTRAŠNJE I SPOLJAŠNJE POVRŠINE

- Površine čistite vlažnom krpom sa mikrovlaknima. Ukoliko su veoma prljave, dodajte nekoliko kapi pH-neutralnog deterdženta. Obrišite suvom krpom.
- Staklo na vratima čistite odgovarajućim tečnim deterdžentom.
- Redovno ili u slučaju prosipanja, uklonite obrtnu ploču i nosač kako biste očistili dno pećnice i uklonili sve ostatke hrane.
- Roštilj nije potrebno čistiti, jer intenzivna toplota sagoreva svu prljavštinu. Ovu funkciju redovno koristite.

## PRIBOR

- Sav pribor, osim crisp tanjira, je bezbedan za korišćenje u mašini za pranje sudova.
- Crisp tanjir treba čistiti u vodi sa blagim deterdžentom. Za upornu prljavštinu, nežno trljajte krpom. Uvek ostavite crisp tanjir da se ohladi pre čišćenja.

## OTKLANJANJE PROBLEMA



Za više informacija preuzmite uputstvo za upotrebu i održavanje sa veb stranice **docs.hotpoint.eu**

Problem	Mogući uzrok	Rešenje
Rerna ne radi.	Nestanak struje. Isključenje iz električne mreže.	Proverite da li postoji dovod električne energije i da li je pećnica priključena na električnu mrežu. Isključite pećnicu i ponovo je uključite kako biste proverili da li je kvar i dalje prisutan.
Pećnica proizvodi zvuk čak i kada je isključena.	Ventilator za hlađenje radi.	Otvorite vrata ili sačekajte da se završi proces hlađenja.
Na displeju se prikazuje slovo „F” uz broj.	Softverska greška.	Kontaktirajte najbliži Postprodajni servis za klijente i recite im broj koji se pojavljuje uz slovo „F”.

## DOKUMENTACIJA UREĐAJA

 Dokumentaciju proizvoda koja uključuje i podatke o energetske potrošnji možete preuzeti na veb stranici **docs.hotpoint.eu**

## KAKO DOĆI DO UPUTSTVA ZA UPOTREBU I ODRŽAVANJE

>  Uputstvo za upotrebu i održavanje možete preuzeti na našoj veb stranici **docs.hotpoint.eu**

(možete da koristite ovaj QR kôd), tako što ćete navesti komercijalnu šifru proizvoda.



> Takođe, možete kontaktirati naš Postprodajni servis za klijente.

## STUPANJE U KONTAKT SA SLUŽBOM ZA KORISNIKE

Naše kontakt detalje možete pronaći u garantnom listu. Prilikom kontaktiranja našeg Postprodajnog servisa, navedite kodove koji se nalaze na pločici za identifikaciju proizvoda.

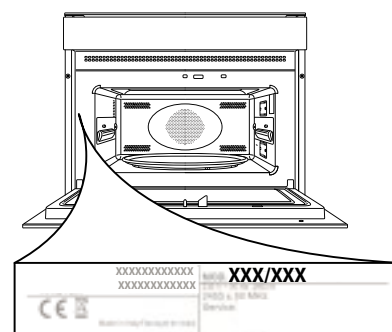



# DAILY REFERENCE GUIDE



**THANK YOU FOR PURCHASING A HOTPOINT - ARISTON PRODUCT**  
To receive more comprehensive help and support, please register your product at [www.hotpoint-ariston.com/register](http://www.hotpoint-ariston.com/register)



You can download the Safety Instruction and the Use and Care Guide by visiting our website [www.hotpoint.eu](http://www.hotpoint.eu) and following the instructions on the back of this booklet.



**Read the safety instructions carefully before using the product**

## PRODUCT DESCRIPTION

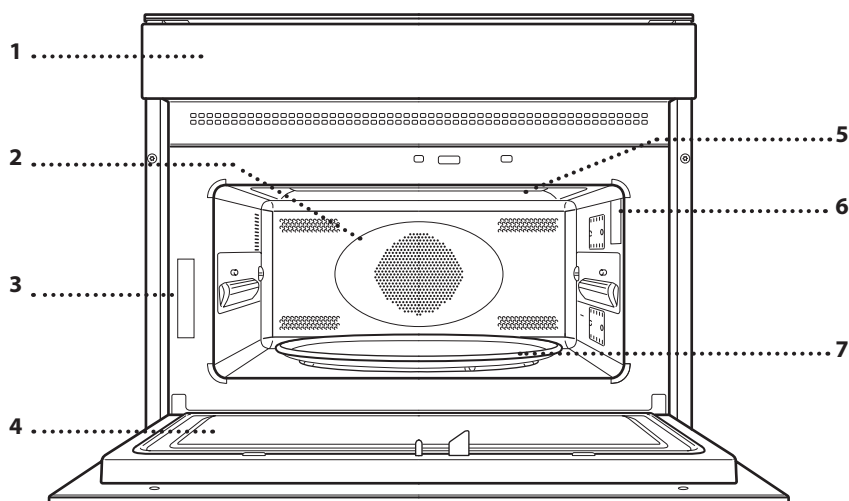

1. Control panel
2. Circular heating element (non-visible)
3. Identification plate (do not remove)
4. Door
5. Upper heating element/grill
6. Light
7. Turntable

## CONTROL PANEL

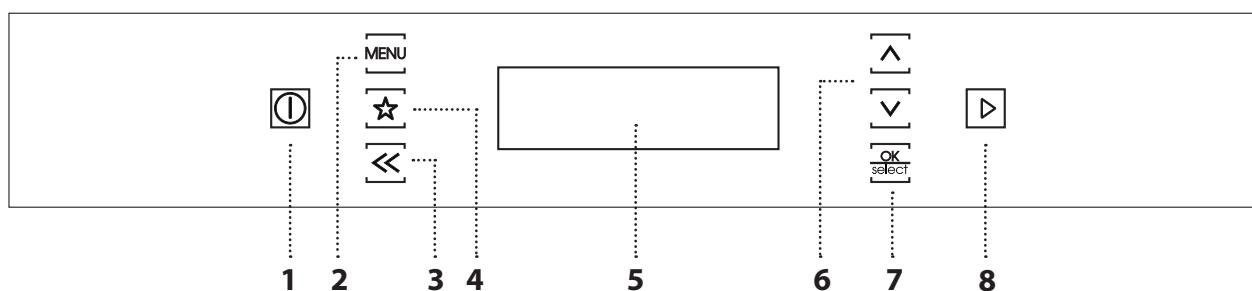

### 1. ON/OFF

For switching the oven on and off and for stopping an active function.

### 2. MENU

For accessing the list of functions.

### 3. BACK

For returning to the previous menu.

### 4. FAVOURITES

For accessing the list of most used functions.

### 5. DISPLAY

**6. NAVIGATION BUTTONS**  
For scrolling through the list of functions, moving the cursor, and changing the settings for a function.

### 7. CONFIRMATION BUTTON

For confirming a function selection or a set value.

### 8. START

For immediately starting a function. When the oven is switched off, it activates the "Jet Start" microwave function.

## TURNTABLE

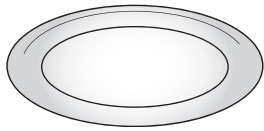

Placed on its support, the glass turntable can be used with all cooking methods. The turntable must always be used as a base for other containers or accessories, with the exception of the rectangular baking plate.

## TURNTABLE SUPPORT

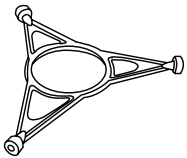

Only use the support for the glass turntable. Do not rest other accessories on the support.

## CRISP PLATE

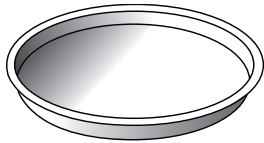

Only for use with the specific "Dynamic Crisp" function. The Crisp plate must always be placed in the centre of the glass turntable and can be pre-heated when empty, using the special function for this purpose only. Place the food directly on the Crisp plate.

## HANDLE FOR THE CRISP PLATE

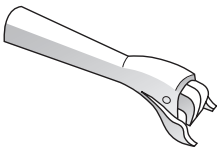

Useful for removing the hot Crisp plate from the oven.

## RECTANGULAR BAKING PLATE

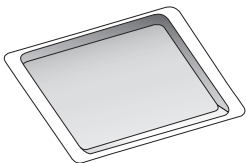

Only use the baking plate with functions that allow for convection cooking; it must never be used in combination with microwaves. Insert the plate horizontally, resting it on the rack in the cooking compartment.

Please note: You do not need to remove the turntable and its support when using the rectangular baking plate.

## LOW WIRE SHELF

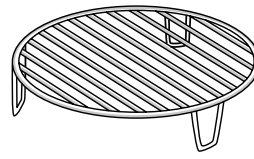

This allows you to place food closer to the grill, for perfectly browning your dish and for optimal hot air circulation. Place the wire shelf on the turntable, making sure that it does not come into contact with other surfaces.

## STEAMER

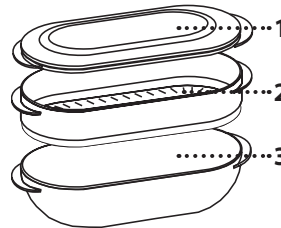

To steam foods such as fish or vegetables, place these in the basket (2) and pour drinking water (100 ml) into the bottom of the steamer (3) to achieve the right amount of steam.

To boil foods such as pasta, rice or potatoes, place these directly on the bottom of the steamer (the basket is not required) and add an appropriate amount of drinking water for the amount you are cooking.

For best results, cover the steamer with the cover (1) provided.

Always place the steamer on the glass turntable and only use it with the appropriate cooking functions, or with microwave functions.

## COVER

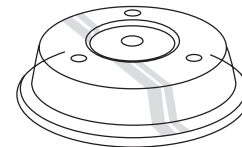

Useful for covering food while it is cooking or heating in the microwave.

The cover reduces splashes, keeps foods moist and can also be used to create two cooking levels.

It is not suitable for use in convection cooking or with any of the grill functions (including "Dynamic Crisp").

Please note: The number of accessories may vary depending on which model is purchased. Other accessories can be purchased separately from the After-sales Service.

**There are a number of accessories available on the market. Before you buy, ensure they are suitable for microwave use and resistant to oven temperatures.**

**Metallic containers for food or drink should never be used during microwave cooking.**

**Always ensure that foods and accessories do not come into contact with the inside walls of the oven.**

**Always ensure that the turntable is able to turn freely before starting the oven. Take care not to unseat the turntable whilst inserting or removing other accessories.**



## MANUAL



### MICROWAVE

For quickly cooking and reheating food or drinks.

POWER	SUGGESTED USE
900 W	Rapid heating of drinks or other foods with a high water content
750 W	Cooking vegetables
650 W	Cooking meat and fish
500 W	Cooking meat sauces, or sauces containing cheese or egg. Finishing off meat pies or pasta bakes
350 W	Slow, gently cooking. Perfect for melting butter or chocolate
160 W	Defrosting frozen foods or softening butter and cheese
90 W	Softening ice cream

Recommended accessories: **Cover**



### DYNAMIC CRISP

For perfectly browning a dish, both on the top and bottom of the food. This function must only be used with the special Crisp plate.

Required accessories: **Crisp plate, handle for the Crisp plate**



### GRILL

For browning, grilling and gratins. We recommend turning the food during cooking. For best results, preheat the grill for 3-5 minutes.

Recommended accessories: **wire shelf**



### GRILL + MW

For quickly cooking and gratinating dishes, combining the microwave and grill functions.

Recommended accessories: **wire shelf**



### TURBO GRILL

For perfect results, combining the grill and convection functions. We recommend turning the food during cooking.

Recommended accessories: **wire shelf**



### TURBO GRILL + MICROWAVE

For quickly cooking and browning your food, combining the microwave, grill and convection oven functions.

Recommended accessories: **wire shelf**



### CONVECTION BAKE

For cooking dishes in a way that achieves similar results to using a conventional oven. The baking plate or other cookware that is suitable for oven use can be used to cook certain foods.

Recommended accessories: **Rectangular baking plate/wire shelf**



### CONVECTION + MICROWAVE

To prepare oven dishes in a short time.

Recommended accessories: **wire shelf**



### QUICK HEAT

For quickly reheating the oven before a cooking cycle. Wait for the function to finish before placing food inside the oven.



## SENSOR

The sensor functions adapt continuously during cooking, allowing you to achieve brilliant results.

The total time does not include preparation or preheating phases.



### DYNAMIC REHEAT

For reheating ready-made food that is either frozen or at room temperature. The oven automatically calculates the values necessary to achieve the best results possible, in the shortest time. Place food onto a microwave safe and heatproof dinner plate or dish.



### DYNAMIC CRISP

For quickly reheating and cooking frozen foods, for a golden, crunchy top. Only use this function with the Crisp plate provided.

Required accessories: **Crisp plate, handle for the Crisp plate**



### DYNAMIC STEAM

For steam-cooking foods such as vegetables or fish, using the steamer provided.

The preparation phase automatically generates steam, bringing the water poured into the bottom of the steamer to the boil. Timings for this phase may vary. The oven then proceeds with steam-cooking the food, according to the time set.

Some indicative cooking times are as follows:

- fresh vegetables (250-500 g): 4-6 minutes;
- frozen vegetables (250-500 g): 5-7 minutes;
- fish fillets (250-500 g): 4-6 minutes.

Required accessories: **Steamer**



## KEEP WARM

For keeping just-cooked food hot and crisp, including meat, fried foods or cakes.

## AUTO AUTOMATIC

With the automatic functions, simply select the weight or quantity of food to achieve the best possible results.



### DYNAMIC DEFROST

For quickly defrosting meat, poultry, fish, vegetables and bread weighing between 100 g and 3 kg.

Food should be placed directly onto the glass turntable.



### CRISPY BREAD DEFROST

For quickly defrosting and reheating rolls, croissants and baguettes. The oven automatically calculates the values necessary to achieve the best results possible (time, power and cooking method).

Required accessories: Crisp plate, handle for the Crisp plate



### RECIPES

**AUTO** This allows you to choose from a range of automatic recipes with pre-set values for optimal cooking. For best results, follow the instructions provided on the display.

Please note: For more information, recipes and helpful advice on using this function, read and download the Use and Care Guide at [www.hotpoint.eu](http://www.hotpoint.eu)



## SETTINGS

For changing the oven settings (language, time, audible signal volume, brightness, Eco mode).

Please note: When Eco mode is active, the brightness of the display will be reduced after a few seconds to save energy. The display is reactivated automatically whenever any of the buttons are pressed, etc.

# USING THE APPLIANCE FOR THE FIRST TIME

## 1. PLEASE SELECT LANGUAGE

You will need to set the language and the time when you switch on the appliance for the first time. The display will show you a list of available languages.

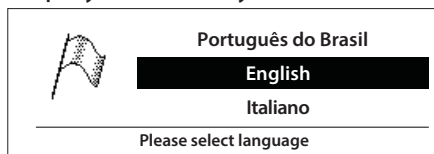

Use **▲** or **▼** to select the language you require and press **OK** select to confirm.

Please note: The language can also be changed later from the "Settings" menu item.

## 2. SET THE TIME

After selecting the language, you will need to set the current time: 12:00 will flash on the display.

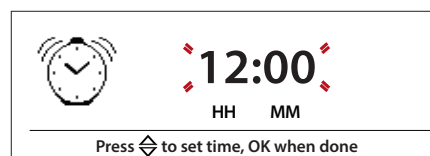

Use **▲** or **▼** to set the time and press **OK** select to confirm.

Please note: You may need to set the time again following lengthy power outages.

# DAILY USE

## 1. SELECT A FUNCTION

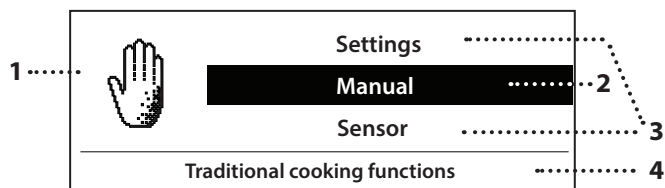

1. Symbol for the function selected
2. Function selected
3. Other available functions
4. Description of the function selected

### SWITCH ON THE OVEN

Press **⏻**: The display will show the main menu.

### NAVIGATE THE MENU

Press **▲** or **▼** to navigate through the main menu and highlight the item you would like to select.

### SELECT AN ITEM FROM THE MENU

Once the item you would like to select is highlighted on the display, press **OK select** to confirm the selection and go to the settings menu (see below) or to the list of functions.

### SELECT A FUNCTION

Press **▲** or **▼** to navigate through the list given. Press **OK select** to confirm and go to the settings menu.

## 2. SETTING AND ACTIVATING THE FUNCTION

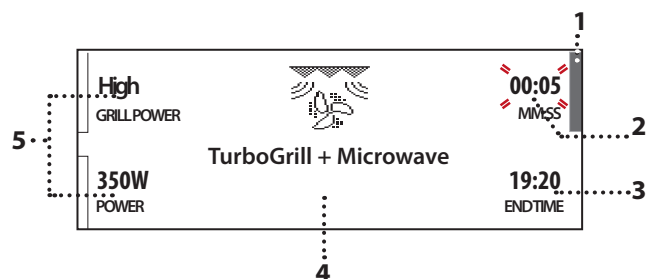

1. Selector cursor  
(highlights the setting selected)
2. Duration
3. Time at which the function will finish
4. Name of the function
5. Settings for the function  
(power, temperature, grill level, weight or quantity, desired degree of cooking, etc.)

### APPLY SETTINGS

Initially, it is possible to set the values of the chosen function based on the sequence given on the display. When the value is flashing, use **▲** or **▼** to set the value and press **OK select** to confirm.

If necessary, use **▲** or **▼** to move the cursor next to the value that you want to change, and press **OK select**. The value will flash.

Use **▲** or **▼** to change the value and press **OK select** to confirm.

### ACTIVATE THE FUNCTION

Once the settings displayed are those that you require, press **▶** to activate the function.

Please note: Where possible, some values can even be changed during cooking.

### . SAFETY LOCK

This function is automatically activated to prevent the oven from being switched on accidentally.



Open and close the door, and then press **▶** to start the function selected.

### . PAUSE

To pause an active function, for example to stir or turn the food, simply open the door. To start it up again, close the door and press **▶**

### . JET START

When the oven is switched off, press **▶** to activate cooking with the microwave function set at full power (900 W) for 30 seconds.

Every time the **▶** button is pressed again, the cooking time will be increased by a further 30 seconds.

## . FAVOURITES

The oven will automatically compile a list of the functions that you use the most. Press the **ⓘ** button to switch on the oven, then press **☆** to display the list of functions you use most frequently.

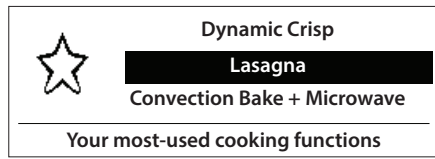

Use **▲** or **▼** to select the function you require, press **OK select** to confirm and then modify – if necessary – the settings according to your needs (those suggested are basic settings).  
Once finished, press **▶** to activate the function.

## . RESIDUAL HEAT

In many cases, when food has been cooked, the oven will activate an automatic cooling process, which will be indicated on the display.

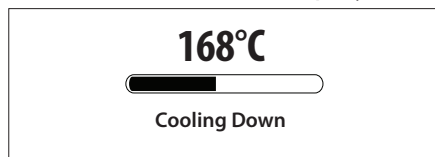

To view the clock during this process, press **◀◀**

Please note: Opening the door temporarily interrupts the process.

## . TIMER

When the oven is switched off, the display can be

used as a timer. To activate the function, press **OK select**. The timer will appear on the display.

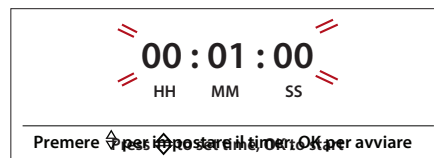

Press **▲** or **▼** to set the length of time you require and then press **OK select** to activate the timer. An audible signal will sound once the timer has finished counting down the selected time.

Please note: The timer does not activate any of the cooking cycles.

To stop the timer at any time, press **ⓘ**

## . KEY LOCK

To lock the keypad, press and hold **OK select** and **◀◀** at the same time for at least five seconds. Do this again to unlock the keypad.

# COOKING TABLE

FOOD	FUNCTION	PREHEAT	TEMP. (°C)/ GRILL LEVEL	POWER (W)	DURA- TION	ACCESSO- RIES
Sponge cakes		-	160-180	-	30-60	
		-	160-180	90	25-50	
Filled pies (cheesecake, strudel, apple tart)		Yes	160-190	-	35-70	
Cookies		Yes	170-180	-	10-20	
Meringues		Yes	100-120	-	40-50	
Rolls		Yes	210-220	-	10-12	
Bread Loaf		Yes	180-200	-	30-35	
Pizza/Pie		Yes	190-220	-	20-40	
Pizza (0.4-0.5 kg)		-	-	-	14-16	











FOOD	FUNCTIONS	PREHEAT	TEMP. (°C)/GRILL LEVEL	POWER (W)	TIME (MIN)	ACCESSORIES
Savoury pies (vegetable pie, quiche Lorraine)		Yes	180-190	-	40-55	 
Quiche Lorraine (1-1.2 kg)		-	-	-	18-20	
Lasagna/baked pasta		-	Medium	350-500	15-40	 
Roast lamb/Veal/Roast beef (1.3-1.5 kg)		-	170-180	-	70-80*	 
		-	160-180	160	50-70*	 
Roast beef – medium (1.3-1.5 kg)		-	170-180	-	40-60*	 
Roast Chicken/Rabbit/Duck (whole 1-1.2 kg)		-	210-220	-	50-70*	 
		-	210-220	350	45-60*	 
Chicken / Rabbit/ Duck (fillets/pieces)		-	Medium - High	350-500	20-40*	 
Chicken Pieces (0.4-1 kg)		-	-	-	12-18	
Baked Whole Fish (whole)		-	High	160-350	20-40	 
Fish fillets/slices		Yes	High	-	15-30*	 
Stuffed vegetables (tomatoes, zucchinis, eggplants)		-	Medium	500-650	25-50	 
Toast		-	High	-	3-6	
Sausages/Kebabs/Spare ribs/Hamburgers		-	Medium - High	-	20-40*	
Sausages/Burgers (0.2-1 kg)		Yes**	-	-	6-16	
Baked Potatoes		-	Medium	350-500	20-40*	 
Potato Wedges (0.3-0.8 kg)		-	-	-	10-20	
Baked fruit		-	Medium	160-350	15-25	 
Vegetable gratin		-	High - medium	-	15-25	 
Fried vegetables (0.3-0.8 kg)		Yes**	-	-	8-18	

\* Turn the food halfway through cooking

\*\* Preheat the Crisp plate for 3-5 minutes

 For more information, recipes and helpful advice on using the automatic functions, read and download the Use and Care Guide at [www.hotpoint.eu](http://www.hotpoint.eu)

 Download the Use and Care Guide from [www.hotpoint.eu](http://www.hotpoint.eu) for the table of tested recipes, compiled for the certification authorities in accordance with the standards IEC 60705 and IEC 60350

FUNCTIONS	Crisp	Grill	Grill + MW	Turbo Grill	Convection Bake	Convection Bake + Microwave
						
ACCESSORIES	Heatproof plate/container suitable for use in microwaves 		Low wire shelf 	Crisp plate 	Rectangular baking plate 	

# CLEANING

**Make sure that the appliance has cooled down before carrying out any maintenance or cleaning.**

**Do not use steam cleaners.**

**Do not use wire wool, abrasive scourers or abrasive/corrosive cleaning agents, as these could damage the surfaces of the appliance.**

## INTERIOR AND EXTERIOR SURFACES

- Clean the surfaces with a damp microfibre cloth. If they are very dirty, add a few drops of pH-neutral detergent. Finish off with a dry cloth.
- Clean the glass in the door with a suitable liquid detergent.
- At regular intervals, or in case of spills, remove the turntable and its support to clean the bottom of the oven, removing all food residue.
- The grill does not need to be cleaned as the intense heat burns away any dirt. Use this function on a regular basis.

## ACCESSORIES

All accessories are dishwasher safe with the exception of the Crisp plate. The Crisp plate should be cleaned using water and a mild detergent. For stubborn dirt, rub gently with a cloth. Always leave the Crisp plate to cool down before cleaning.

# TROUBLESHOOTING



Download the Use and Care Guide at [www.hotpoint.eu](http://www.hotpoint.eu) for more information

Problem	Possible cause	Solution
The oven is not working.	Power cut. Disconnection from the mains.	Check for the presence of mains electrical power and whether the oven is connected to the electricity supply. Turn off the oven and restart it to see if the fault persists
The oven makes noises, even when it is switched off.	Cooling fan active.	Open the door or wait until the cooling process has finished.
The display shows the letter "F" followed by a number.	Software fault.	Contact your nearest Client After-sales Service Centre and state the number following the letter "F".

## PRODUCT FICHE

[www](http://www.hotpoint.eu) A complete specification for the product, including energy efficiency ratings, can be downloaded from our website [www.hotpoint.eu](http://www.hotpoint.eu)

## HOW TO OBTAIN THE USE AND CARE GUIDE

> [www](http://www.hotpoint.eu) Download the Use and Care Guide from our website [www.hotpoint.eu](http://www.hotpoint.eu) (you can use this QR code), specifying the product's commercial code.



> Alternatively, contact our Client After-sales Service

## CONTACTING OUR AFTER-SALES SERVICE

You can find our contact details in the warranty manual. When contacting our Client After-sales Service, please state the codes provided on your product's identification plate.

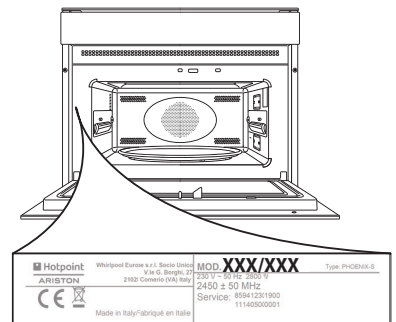



# GUÍA DE CONSULTA DIARIA



## GRACIAS POR HABER ADQUIRIDO UN PRODUCTO HOTPOINT - ARISTON

Si desea recibir asistencia y soporte adicionales, registre su producto en [www.hotpoint.eu/register](http://www.hotpoint.eu/register)



Puede descargarse las Instrucciones de seguridad y la Guía de uso y cuidado de nuestra página web [docs.hotpoint.eu](http://docs.hotpoint.eu) siguiendo las instrucciones que figuran al dorso de este documento.

**!** Antes de utilizar por primera vez el aparato lea detenidamente la guía de Higiene y seguridad y de Uso y cuidado.

## DESCRIPCIÓN DEL PRODUCTO

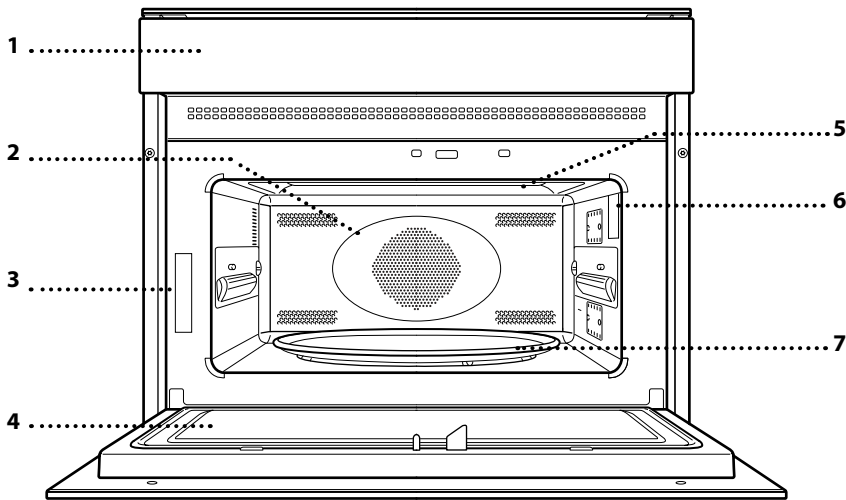

1. Panel de mandos
2. Resistencia circular (no visible)
3. Placa de características (no debe retirarse)
4. Puerta
5. Resistencia superior/grill
6. Ligera
7. Plato giratorio

## PANEL DE CONTROL

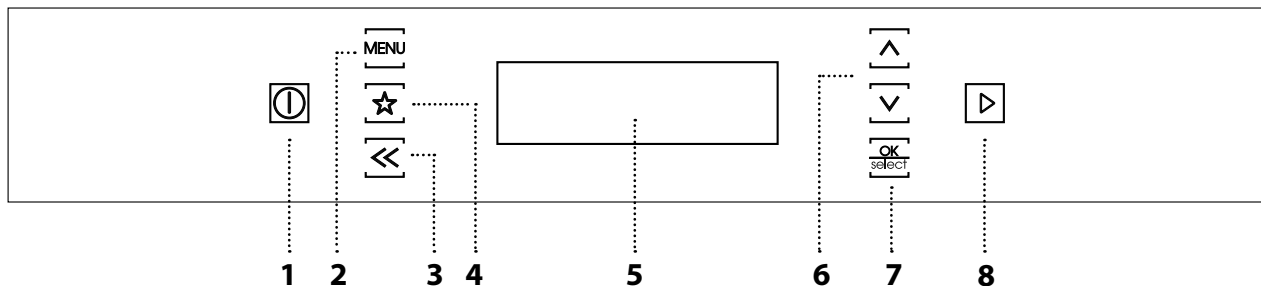

### 1. ACTIVADO/DESACTIVADO

Sirve para encender o apagar el horno, y para detener una función activa.

### 2. MENÚ

Para acceder a la lista de funciones.

### 3. ATRÁS

Sirve para volver al menú anterior.

### 4. FAVORITAS

Para acceder a la lista de funciones de métodos abreviados.

### 5. PANTALLA

### 6. BOTONES DE NAVEGACIÓN

Para desplazarse por la lista de funciones, mover el cursor y cambiar las configuraciones de una función.

### 7. BOTÓN DE CONFIRMACIÓN

Para confirmar la selección de una función o un valor definido.

### 8. INICIO

Para iniciar inmediatamente una función. Cuando el horno está apagado, activa la función de **JET START** del microondas.

# Hotpoint

ARISTON

## PLATO GIRATORIO

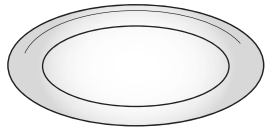

El plato giratorio debe estar colocado en su soporte y puede utilizarse en todos los métodos de cocción.

El plato giratorio siempre debe utilizarse como base para otros

contenedores o accesorios, excepto con el plato para hornear rectangular.

## SOPORTE DEL PLATO GIRATORIO

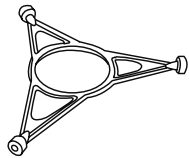

Utilice el soporte solamente para el plato giratorio de cristal. No coloque otros accesorios en el soporte.

## PLATO CRISP

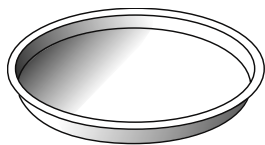

Debe utilizarse solamente con la función "Dynamic Crisp".

La bandeja Crisp debe colocarse siempre en el centro del plato giratorio y puede precalentarse vacía utilizando la función

especial para ello. Coloque la comida directamente en la bandeja Crisp.

## ASA DE LA BANDEJA CRISP

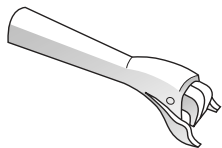

Muy práctica para sacar la bandeja Crisp caliente del horno.

## PLATO PARA HORNEAR RECTANGULAR

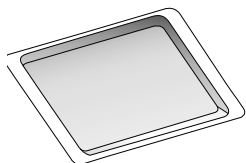

Utilice el plato para hornear rectangular exclusivamente con las funciones que permiten la cocción por convección; No lo utilice nunca en combinación con el microondas. Introduzca el

plato horizontalmente, apoyándolo en la rejilla del compartimento de cocción.

Nota: No es necesario que quite el plato giratorio ni su soporte cuando utilice el plato para hornear.

## PARRILLA INFERIOR

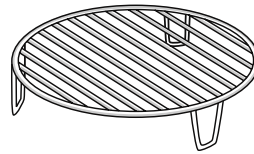

Con ella podrá colocar los alimentos más cerca del grill para obtener un dorado perfecto y una mejor circulación del aire. Coloque la rejilla en el plato giratorio, asegurándose de que

no entre en contacto con otras superficies.

## OLLA A VAPOR

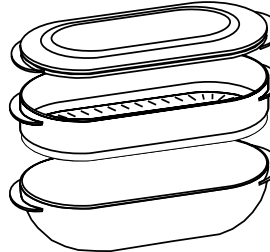

1 Para cocinar al vapor alimentos como pescados o verduras, colóquelos en el cesto (2) y ponga agua potable (100 ml) en el fondo de la olla a vapor (3) para crear la cantidad de vapor correcta.

Para hervir alimentos como pasta, arroz, patatas, colóquelos directamente en el fondo de la olla a vapor (no es necesario el cesto) y añada la cantidad de agua adecuada a la cantidad de alimentos que esté cocinando.

Para obtener los mejores resultados, cubra la olla a vapor con la tapa (1) suministrada. Coloque siempre la olla a vapor en el plato giratorio y utilícela solamente con las funciones de cocción adecuadas o con las funciones de microondas.

## TAPA

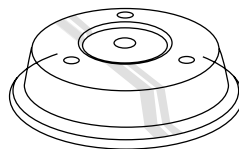

Es útil para cubrir los alimentos cuando se cocina o se calienta en el microondas.

La tapa reduce las salpicaduras, mantiene la humedad de los alimentos y también se puede

utilizar para crear dos niveles de cocción.

No es apta para utilizarla con las funciones de cocción por convección ni con las funciones de grill (incluyendo "Dynamic Crisp").

Nota: El número de accesorios puede variar de un modelo a otro. Se pueden adquirir otros accesorios por separado en el Servicio Postventa.

**Hay varios accesorios disponibles en el mercado. Antes de adquirirlos, asegúrese de que son aptos para el microondas y resistentes a las temperaturas del horno.**

**Los contenedores metálicos para alimentos o bebidas no deben utilizarse nunca para la cocción con el microondas.**

**Asegúrese siempre de que ni los alimentos ni los accesorios entren en contacto con las paredes internas del horno.**

**Compruebe siempre que el plato giratorio gira sin problemas antes de poner en marcha el horno. Tenga cuidado de no desencajar el plato giratorio cuando introduzca o saque otros accesorios.**

**MANUAL** **MICROONDAS**

Para cocinar y recalentar alimentos o bebidas con rapidez.

POTENCIA	USO RECOMENDADO
<b>900 W</b>	Calentamiento rápido de bebidas u otros alimentos con un alto contenido en agua
<b>750 W</b>	Cocción de verduras
<b>650 W</b>	Cocción de carne y pescado
<b>500 W</b>	Cocción de salchichas a base de carne o que contengan queso o huevo. Acabado de pasteles de carne o pasta al horno
<b>350 W</b>	Cocción lenta y suave. Perfecta para derretir mantequilla o chocolate
<b>160 W</b>	Descongelar alimentos o ablandar mantequilla o queso
<b>90 W</b>	Ablandar helados

Accesorios recomendados: **Tapa**

**DYNAMIC CRISP**

Para dorar perfectamente un alimento, tanto por arriba como por abajo. Con esta función es necesario utilizar siempre la bandeja crisp.

Accesorios necesarios: **Bandeja Crisp, asa de la bandeja Crisp**

**GRILL**

Para dorar y gratinar. Es recomendable girar los alimentos durante la cocción. Para obtener los mejores resultados, precaliente el grill durante 3-5 minutos.

Accesorios recomendados: **parrilla**

**GRILL + MICROONDAS**

Para cocinar y gratinar rápidamente, combinando las funciones de microondas y las de grill.

Accesorios recomendados: **parrilla**

**TURBO GRILL**

Para lograr un resultado perfecto, combinando las funciones de grill y convección. Es recomendable girar los alimentos durante la cocción.

Accesorios recomendados: **parrilla**

**TURBO GRILL + MICROONDAS**

Para cocinar y dorar rápidamente, combinando las funciones de microondas, grill y convección.

Accesorios recomendados: **parrilla**

**AIRE IMPULSADO**

Sirve para cocinar platos y obtener un resultado similar al de un horno convencional. Para cocinar ciertos alimentos, se puede emplear el plato para hornear u otros recipientes de cocción aptos para uso en el horno.

Accesorios recomendados: **Plato para hornear rectangular/parrilla**

**AIRE IMPULSADO + MICROONDAS**

Para preparar platos de horno en poco tiempo.

Accesorios recomendados: **parrilla**

**CALOR RÁPIDO**

Para calentar rápidamente el horno antes de un ciclo de cocción.

Espera a que termine la función antes de introducir los alimentos en el horno.

**SENSOR**

Las funciones de sensor se adaptan continuamente durante la cocción para asegurar un resultado excelente. El tiempo total no incluye las fases de preparación ni precalentamiento.

**DYNAMIC REHEAT**

Sirve para calentar alimentos precocinados que estén congelados o a temperatura ambiente. El horno calcula automáticamente los valores necesarios para lograr el mejor resultado en el menor tiempo posible. Coloque los alimentos en una bandeja o plato para microondas.

**DYNAMIC CRISP**

Para calentar y cocinar rápidamente alimentos congelados, con un acabado dorado y crujiente. Use esta función solamente con la bandeja Crisp.

Accesorios necesarios: **Bandeja Crisp, asa de la bandeja Crisp**

**DYNAMIC STEAM**

Para cocinar al vapor alimentos como verduras o pescado, utilizando la olla a vapor suministrada. La fase de preparación genera automáticamente el vapor, poniendo en ebullición el agua colocada en el fondo de la olla a vapor. Los tiempos necesarios para esta fase pueden variar. Después, el horno procede a cocinar los alimentos al vapor según el tiempo programado.

A continuación se indican algunos de tiempos de cocción orientativos:

- verduras frescas (250-500 g): 4-6 minutos;
- verduras congeladas (250-500 g): 5-7 minutos;
- filetes de pescado (250-500 g): 4-6 minutos.

Accesorios necesarios: **Olla a vapor**



## GUARDAR CALIENTE

Para mantener calientes y crujientes los alimentos recién cocinados, incluyendo carne, fritos o pasteles.

## AUTO AUTOMÁTICO

Con las funciones automáticas, solamente deberá seleccionar el peso o la cantidad de alimentos para lograr el mejor resultado.



### DYNAMIC DEFROST

Para descongelar rápidamente carne, aves, pescado, verduras y pan con un peso comprendido entre 100 g y 3 kg. Los alimentos deben colocarse directamente en el plato giratorio.



### DESCONGELAR PAN CRUJIENTE

Para descongelar rápidamente y recalentar bollos, croissants y barras de pan. El horno calcula automáticamente los valores necesarios para lograr el mejor resultado (tiempo, potencia y método de cocción).

Accesorios necesarios: Bandeja Crisp, asa de la bandeja Crisp



### RECETAS

**AUTO** Con esta función podrá elegir entre una amplia variedad de recetas automáticas con valores predefinidos para una cocción excelente. Para obtener los mejores resultados, siga las instrucciones de la pantalla.

Nota: si desea más información, recetas y consejos útiles para utilizar esta función, lea y descargue la Guía de uso y cuidado en [docs.hotpoint.eu](http://docs.hotpoint.eu)



## AJUSTES

Para cambiar las configuraciones del horno (idioma, hora, volumen de las señales sonoras, brillo, modo Eco).

Nota: Cuando el modo Eco está activado, al cabo de unos segundos se reduce el brillo de la pantalla para ahorrar energía. La pantalla se vuelve a activar automáticamente al pulsar cualquier botón, etc.

# PRIMER USO

## 1. SELECCIONE IDIOMA

La primera vez que encienda el aparato, tendrá que seleccionar el idioma y ajustar la hora. La pantalla mostrará una lista de idiomas disponibles.

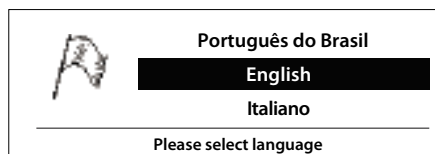

Utilice **▲** o **▼** para seleccionar el idioma deseado y pulse **OK select** para confirmar.

Nota: También puede cambiar el idioma más tarde desde la opción «Ajustes» del menú.

## 2. CÓMO CONFIGURAR LA HORA

Después de seleccionar el idioma, tendrá que configurar la hora actual: en la pantalla aparecerá «12:00».



Utilice **▲** o **▼** para establecer la hora y pulse **OK select** para confirmar.

Nota: Después de un corte de suministro prolongado, es posible que tenga que volver a configurar la hora.

# USO DIARIO

## 1. SELECCIONAR UNA FUNCIÓN

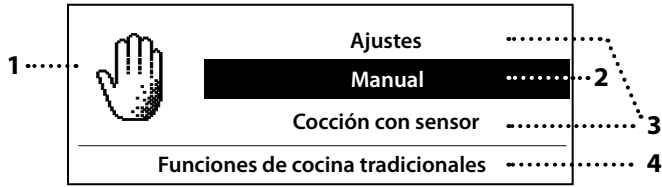

1. Símbolo para la función seleccionada
2. Función seleccionada
3. Otras funciones disponibles
4. Descripción de la función seleccionada

### ENCENDER EL HORNO

Pulse ①: en la pantalla aparecerá el menú principal.

### NAVEGAR POR EL MENÚ

Pulse  $\wedge$  o  $\vee$  para navegar por el menú principal y resaltar la opción que desea seleccionar.

### SELECCIONAR UNA OPCIÓN DEL MENÚ

Una vez que aparezca resaltada en la pantalla la opción que desea seleccionar, pulse  $\frac{OK}{select}$  para confirmar e ir al menú de configuración (véase abajo) o a la lista de funciones.

### SELECCIONAR UNA FUNCIÓN

Pulse  $\wedge$  o  $\vee$  para desplazarse por la lista. Pulse  $\frac{OK}{select}$  para confirmar e ir al menú de configuración.

## 2. CONFIGURAR Y ACTIVAR UNA FUNCIÓN

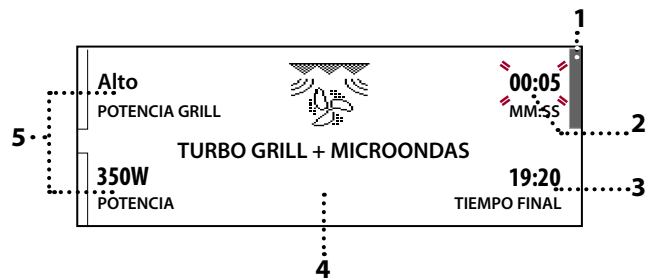

1. Selector del cursor (resalta la configuración seleccionada)
2. Duración
3. Hora a la que terminará la función
4. Nombre de la función
5. Ajustes para la función (potencia, temperatura, nivel de grill, peso o cantidad, grado de cocción, etc.)

### APLICAR LOS AJUSTES

Inicialmente, puede ajustar los valores de la función seleccionada basándose en la secuencia que aparece en la pantalla. Cuando el valor está parpadeando, utilice  $\wedge$  o  $\vee$  para establecer el valor y pulse  $\frac{OK}{select}$  para confirmar.

Si fuera necesario, utilice  $\wedge$  o  $\vee$  para desplazar el cursor cerca del valor que desee cambiar, y pulse  $\frac{OK}{select}$ . El valor parpadeará.

Utilice  $\wedge$  o  $\vee$  para cambiar el valor y pulse  $\frac{OK}{select}$  para confirmar.

### ACTIVAR LA FUNCIÓN

Una vez que los ajustes que aparecen en pantalla sean los deseados, pulse  $\blacktriangleright$  para activar la función.

Nota: Hay algunos valores programados que se pueden modificar durante la cocción.

### . BLOQUEO DE SEGURIDAD

Esta función se activa automáticamente para evitar la activación accidental del horno.

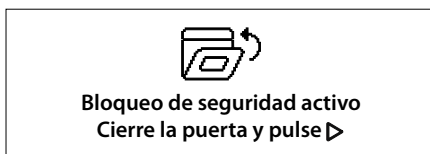

Abra y cierre la puerta, y luego pulse  $\blacktriangleright$  para iniciar la función seleccionada.

### . PAUSA



Para detener una función activa, por ejemplo para mover o girar la comida, solamente tendrá que abrir la puerta. Para reanudar la función, cierre la puerta y pulse  $\blacktriangleright$ .

### . JET START





Cuando el horno esté apagado, pulse  $\blacktriangleright$  para activar la cocción con la función microondas a la potencia máxima (900 W) durante 30 segundos.

Cada vez que pulse el botón  $\blacktriangleright$ , el tiempo de cocción se incrementará en otros 30 segundos.

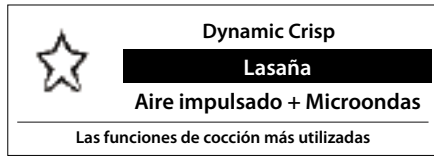
## . FAVORITAS

El horno elaborará automáticamente una lista con las funciones que más utiliza. Pulse el botón  para encender el horno y, a continuación, pulse  para que aparezca la lista de funciones que utiliza con más frecuencia.



Utilice  o  para seleccionar la función deseada, pulse  para confirmar y, a continuación, si es necesario, modifique los ajustes según sus necesidades (los valores recomendados son ajustes de base). Cuando haya terminado, pulse  para activar la función.

## . CALOR RESIDUAL

En muchos casos, después de haber cocinado alimentos, el horno activa automáticamente un proceso de refrigeración que se indicará en la pantalla.







Para ver el reloj durante este proceso, pulse .

Nota: Si abre la puerta, se interrumpirá momentáneamente el proceso.

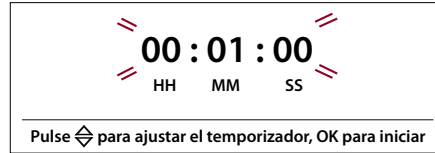
## . TEMPORIZADOR



Cuando el horno está apagado, la pantalla puede utilizarse como temporizador. Para activar la función, pulse . El temporizador aparecerá en la pantalla.

























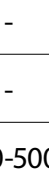



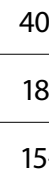

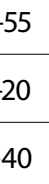
Pulse  o  para seleccionar el tiempo que necesita y pulse  para activar el temporizador. Una vez que haya finalizado la cuenta atrás sonará una señal acústica.

Nota: El temporizador no activa ninguno de los ciclos de cocción. Para detener el temporizador en cualquier momento, pulse .

## . CIERRE

Para bloquear las teclas, mantenga pulsado  y  al mismo tiempo durante al menos cinco segundos. Para desbloquearlo, siga el mismo proceso.

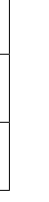
# TABLA DE COCCIÓN

ALIMENTO	FUNCIÓN	PRECALENTAR	TEMP. (°C)/ NIVEL GRILL	POTENCIA (W)	DURACIÓN	ACCESORIOS
Bizcochos esponjosos		-	160-180	-	30-60	 
		-	160-180	90	25-50	 
Tartas rellenas (tarta de queso, strudel, tarta de manzana)		Sí	160-190	-	35-70	 
Galletas		Sí	170-180	-	10-20	
Merengues		Sí	100-120	-	40-50	
Bollos		Sí	210-220	-	10-12	
Barra de pan		Sí	180-200	-	30-35	
Pizza/Tarta		Sí	190-220	-	20-40	
Pizza (0,4-0,5 kg)		-	-	-	14-16	
Tartas saladas (tarta de verduras, quiche Lorraine)		Sí	180-190	-	40-55	 
Quiche lorraine (1-1,2 kg)		-	-	-	18-20	
Lasaña/pasta al horno			Media	350-500	15-40	 

ALIMENTO	FUNCIÓN	PRECALENTAR	TEMP. (°C)/ NIVEL GRILL	POTENCIA (W)	DURACIÓN	ACCESORIOS
<b>Cordero asado / ternera / rosbif</b> (1,3-1,5 kg)		-	170-180	-	70-80*	
		-	160-180	160	50-70*	
<b>Rosbif: al punto</b> (1,3-1,5 kg)		-	170-180	-	40-60*	
<b>Pollo asado / Conejo / Pato</b> (entero 1-1,2 kg)		-	210-220	-	50-70*	
		-	210-220	350	45-60*	
<b>Pollo/Conejo/Pato</b> (filetes/piezas)		-	Medio-Alto	350-500	20-40*	
<b>Presas de pollo</b> (0,4-1 kg)		-	-	-	12-18	
<b>Pescado al horno</b> (entero)		-	Alta	160-350	20-40	
<b>Filetes/rodajas de pescado</b>		Sí	alta	-	15-30*	
<b>Verduras rellenas</b> (tomates, calabacines, berenjenas)		-	Media	500-650	25-50	
<b>Tostada</b>		-	alta	-	3-6	
<b>Salchichas / brochetas / costillas / hamburguesas</b>		-	Medio-Alto	-	20-40*	
<b>Salchichas/Hamburguesas</b> (0,2-1 kg)		Sí**	-	-	6-16	
<b>Patatas asadas</b>		-	Media	350-500	20-40*	
<b>Patatas fr. en cuñas</b> (0,3-0,8 kg)		-	-	-	10-20	
<b>Fruta asada</b>		-	Media	160-350	15-25	
<b>Verduras gratinadas</b>		-	Alto - medio	-	15-25	
<b>Verduras fritas</b> (0,3-0,8 kg)		Sí**	-	-	8-18	

\* Dar la vuelta al alimento a mitad de la cocción

\*\* Precaliente el plato crisp de 3 a 5 minutos

[www.docs.hotpoint.eu](http://www.docs.hotpoint.eu) Si desea más información, recetas y consejos útiles para sobre el uso de las funciones automáticas, lea y descargue la Guía de uso y cuidado en **docs.hotpoint.eu**

Descargue la Guía de uso y cuidado de **docs.hotpoint.eu** donde encontrará la tabla de las recetas probadas, cumplimentada por los órganos de certificación de conformidad con las normas IEC 60705 y IEC 60350.

FUNCIÓNES	Crisp	Grill	Grill + microondas	Turbo Grill	Aire impulsado	Aire impulsado + Microondas
ACCESORIOS	Plato resistente al calor/ contenedor apto para el microondas 		Parrilla inferior 	Bandeja crisp 		Plato para hornear rectangular 

# LIMPIEZA

**Asegúrese de que el aparato se haya enfriado antes de llevar a cabo las tareas de mantenimiento o limpieza.**

**No utilice aparatos de limpieza con vapor.**

**No utilice estropajos de acero, estropajos abrasivos ni productos de limpieza abrasivos/corrosivos, ya que podrían dañar las superficies del aparato.**

## SUPERFICIES INTERNAS Y EXTERNAS

- Limpie las superficies con un paño húmedo de microfibra. Si están muy sucias, añada unas gotas de detergente neutro al agua. Seque con un paño seco.
- Limpie el cristal de la puerta con un detergente líquido adecuado.
- Con regularidad, o en caso de salpicaduras, quite el plato giratorio de su soporte para limpiar la parte inferior del horno y eliminar todos los restos de comida.
- No es necesario limpiar el grill ya que la alta temperatura que genera quema toda la suciedad. Utilice esta función con regularidad.

## ACCESORIOS

- Todos los accesorios son aptos para el lavavajillas, excepto la bandeja Crisp.
- La bandeja Crisp debe limpiarse con agua y un detergente suave. Para la suciedad más resistente, frote suavemente con un paño. Deje enfriar siempre la bandeja Crisp antes de limpiarla.

# RESOLUCIÓN DE PROBLEMAS



Para más información, descargue la Guía de uso y cuidado de [docs.hotpoint.eu](http://docs.hotpoint.eu)

Problema	Posible causa	Solución
El horno no funciona.	Corte de suministro. Desconexión de la red eléctrica.	Compruebe que haya corriente eléctrica en la red y que el horno esté enchufado a la toma de electricidad. Apague el horno y vuelva a encenderlo para comprobar si se ha solucionado el problema.
El horno hace ruido, incluso cuando está apagado.	Ventilador de refrigeración activado.	Abra la puerta o espere a que finalice el proceso de enfriamiento.
En la pantalla aparecerá la letra «F» seguida de un número.	Fallo del software.	Póngase en contacto con el Servicio Postventa más cercano e indique el número que aparece detrás de la letra «F».

## TARJETA DE DATOS DEL PRODUCTO

La ficha del producto, que incluye los datos de energía de este aparato, se puede descargar en el sitio web [docs.hotpoint.eu](http://docs.hotpoint.eu)

## CÓMO OBTENER LA GUÍA DE USO Y CUIDADO

> Descárguese la Guía de uso y cuidado en el sitio web [docs.hotpoint.eu](http://docs.hotpoint.eu) (se puede usar este código QR) indicando el código del producto.



> También puede ponerse en contacto con nuestro Servicio Postventa.

## CÓMO PONERSE EN CONTACTO CON NUESTRO SERVICIO POSTVENTA

Encontrará nuestros datos de contacto en el manual de garantía. Cuando se ponga en contacto con nuestro Servicio Postventa, deberá indicar los códigos que figuran en la placa de características de su producto.

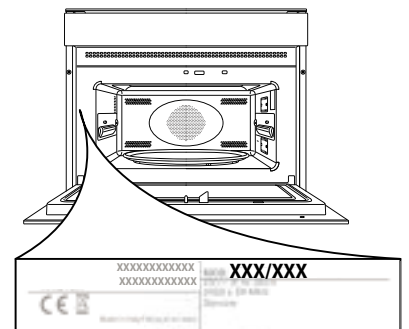



# GUIDA RAPIDA



## GRAZIE PER AVER ACQUISTATO UN PRODOTTO HOTPOINT - ARISTON

Per ricevere un'assistenza più completa, registrare il prodotto su [www.hotpoint.eu/register](http://www.hotpoint.eu/register)



Scaricare le istruzioni per la sicurezza e le istruzioni per l'uso collegandosi al sito [docs.hotpoint.eu](http://docs.hotpoint.eu) e seguire la procedura indicata sul retro.

**!** Leggere attentamente le istruzioni per la sicurezza prima di utilizzare il prodotto.

## DESCRIZIONE PRODOTTO

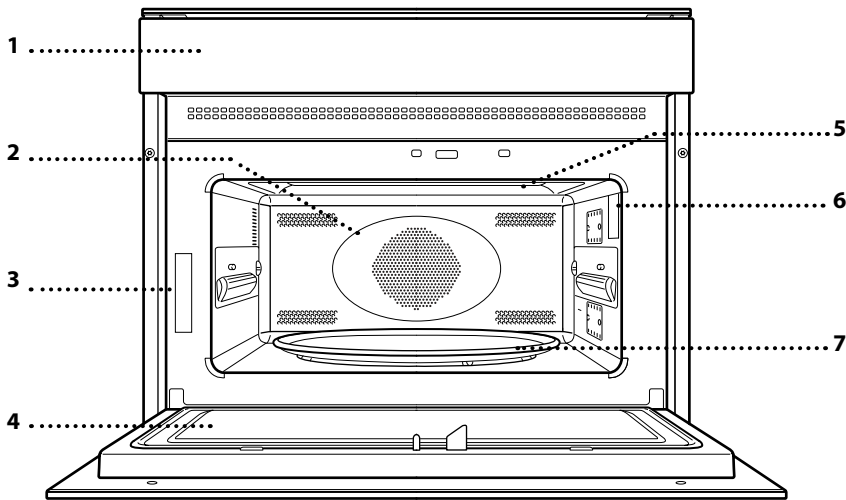

1. Pannello di controllo
2. Resistenza circolare (non visibile)
3. Targhetta matricola (da non rimuovere)
4. Porta
5. Resistenza superiore / grill
6. Luce
7. Piatto rotante

## PANNELLO DI CONTROLLO

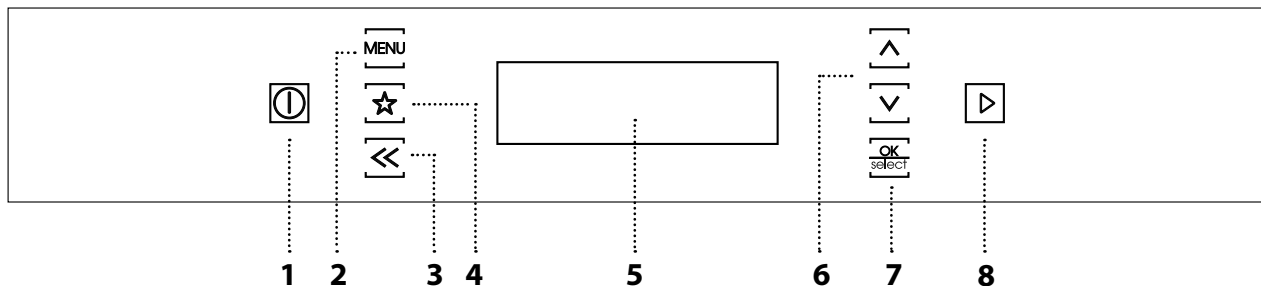

### 1. ON/OFF

Per accendere e spegnere il forno o arrestare un funzione attiva.

### 2. MENU

Per accedere alla lista delle funzioni.

### 3. INDIETRO

Per tornare alla schermata precedente.

### 4. PREFERITI

Per accedere alle lista delle funzioni più utilizzate.

### 5. DISPLAY

### 6. TASTI DI NAVIGAZIONE

Per scorrere la lista delle funzioni, muovere il cursore, modificare le impostazioni di una funzione.

### 7. TASTO DI CONFERMA

Per confermare la selezione di una funzione o un valore impostato.

### 8. AVVIO

Per avviare immediatamente una funzione. A forno spento, avvia la funzione microonde "Jet Start".

# Hotpoint

ARISTON

## PIATTO ROTANTE

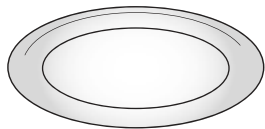

Appoggiato sull'apposito supporto, il piatto rotante in vetro può essere utilizzato in tutte le modalità di cottura. Il piatto rotante va sempre usato come base per altri contenitori o accessori ad eccezione della teglia rettangolare.

## SUPPORTO PIATTO ROTANTE

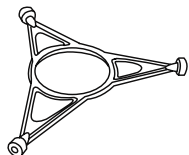

Il supporto va utilizzato solo per il piatto rotante di vetro, e non come appoggio per gli altri accessori.

## PIATTO CRISP

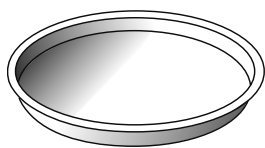

Da usarsi solo con l'apposita funzione "Dynamic Crisp". Il piatto Crisp deve essere sempre appoggiato al centro del piatto rotante in vetro e può essere preriscaldato a vuoto, utilizzando

solo la speciale funzione dedicata. Disporre gli alimenti direttamente sul piatto Crisp.

## MANIGLIA PER PIATTO CRISP

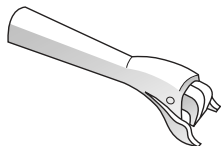

Utile per rimuovere il piatto Crisp caldo dal forno.

## TEGLIA RETTANGOLARE

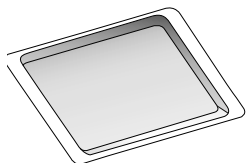

Usare la teglia da forno solo per le funzioni che prevedono la cottura ventilata; non usarla mai in combinazione con le microonde. Inserirla orizzontalmente, appoggiandola sopra l'apposita

guida nella cavità.

Nota: non è necessario togliere il piatto rotante e il suo supporto durante l'utilizzo della teglia rettangolare.

## GRIGLIA BASSA

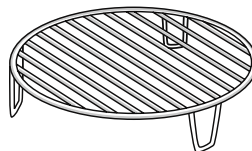

Permette di avvicinare il cibo al grill, assicurandone una piacevole doratura, e una ottimale circolazione dell'aria calda. Appoggiare la griglia sul piatto rotante, evitando che venga a

contatto con altre superfici.

## VAPORIERA

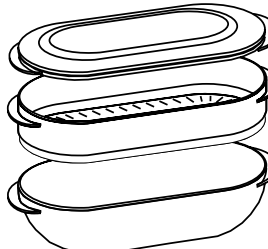

1 Per cuocere a vapore alimenti come pesce o verdure, appoggiarli sul cestello (2) e versare acqua potabile (100 ml) sul fondo della vaporiera (3) per ottenere una corretta quantità di vapore.

Per bollire alimenti come pasta, riso o patate, appoggiarli direttamente sul fondo della vaporiera (non è necessario il cestello), aggiugnendo acqua potabile a seconda della quantità degli alimenti.

Per garantire i migliori risultati di cottura, chiudere la vaporiera con l'apposito coperchio (1). Appoggiare sempre la vaporiera sul piatto rotante in vetro e usarla esclusivamente con le funzioni di cottura dedicate o quella a microonde.

## COPERCHIO

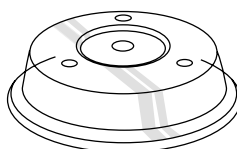

Utile per coprire i recipienti durante la cottura e il riscaldamento a microonde. Il coperchio permette di ridurre gli schizzi, trattenere l'umidità degli alimenti e può essere utilizzato

anche per creare due livelli di cottura. Non è adatto alle cotture ventilate o che attivano il grill (compreso "Dynamic Crisp").

Note: il numero degli accessori può variare in base al modello acquistato. Altri accessori possono essere acquistati separatamente presso il Servizio Assistenza Clienti.

**In commercio sono disponibili diversi accessori. Prima di acquistarli, accertarsi che siano idonei alla cottura a microonde e in forno.**

**Contenitori metallici per cibi o bevande non vanno mai usati durante una cottura a microonde.**

**Verificare che alimenti e accessori non tocchino le pareti interne del forno.**

**Prima di avviare il forno, assicurarsi sempre che il piatto rotante possa ruotare liberamente. Fare attenzione a non spostare il piatto rotante dalla sua sede mentre si inseriscono o rimuovono altri accessori.**

**MANUALE** **MICROONDE**

Per cuocere e riscaldare rapidamente alimenti o bevande.

POTENZA	USO CONSIGLIATO
<b>900 W</b>	Riscaldamento rapido di bevande o altri alimenti ad alto contenuto di acqua
<b>750 W</b>	Cottura di vegetali
<b>650 W</b>	Cottura di carne e pesce
<b>500 W</b>	Cottura di sughi di carne, salse con formaggio o uova. Finitura di sfornati di carne o paste al forno
<b>350 W</b>	Cotture lente e delicate. Per fondere burro o cioccolato
<b>160 W</b>	Scongelare alimenti surgelati o ammorbidire burro e formaggi
<b>90 W</b>	Ammorbidire il gelato

Accessorio suggerito: **coperchio**

 **DYNAMIC CRISP**

Per ottenere una doratura perfetta sia sulla superficie superiore che su quella inferiore del cibo. Questa funzione richiede esclusivamente l'utilizzo dello speciale piatto Crisp.

Accessori necessari: **piatto crisp, maniglia per piatto crisp**

 **GRILL**

Per dorare, grigliare o gratinare le pietanze. Si consiglia di girare gli alimenti durante la cottura. Si raccomanda di preriscaldare il grill per 3-5 minuti.

Accessorio suggerito: **griglia**

 **GRILL + MICROONDE**

Per cuocere e gratinare rapidamente le pietanze combinando le microonde con il grill.

Accessorio suggerito: **griglia**

 **TURBO GRILL**

Per ottenere risultati ottimali nella cottura combinando l'azione del grill alla funzione ventilato. Si consiglia di girare gli alimenti durante la cottura.

Accessorio suggerito: **griglia**

 **TURBO GRILL + MICROONDE**

Per cuocere e dorare velocemente il cibo combinando l'azione delle microonde, del grill e del forno ventilato.

Accessorio suggerito: **griglia**

**VENTILATO**

Per cuocere le pietanze con risultati analoghi a quelli di un forno tradizionale. Per la cottura di alcuni alimenti è possibile usare la teglia o utilizzare recipienti adatti alla cottura in forno.

Accessorio suggerito: **teglia rettangolare / griglia**

**VENTILATO + MICROONDE**

Per preparare piatti al forno in minor tempo.

Accessorio suggerito: **griglia**

**RISCALDAMENTO RAPIDO**

Per riscaldare rapidamente il forno prima di un ciclo di cottura.

Attendere il termine della funzione prima di inserire gli alimenti nel forno.

**SENSOR**

Le funzioni sensor permettono di ottenere risultati ottimali adattandosi continuamente alla cottura in corso. La durata totale non include le fasi di rilevazione o preriscaldamento.

**DYNAMIC REHEAT**

Per riscaldare cibi pronti, sia surgelati che a temperatura ambiente.

Il forno calcolerà automaticamente i valori necessari per ottenere i migliori risultati possibili nel minor tempo. Disporre il cibo su un piatto da portata resistente al calore e alle microonde.

**DYNAMIC CRISP**

Per riscaldare e cuocere rapidamente alimenti surgelati, creando una superficie dorata e croccante. Usare la funzione solo in combinazione con il piatto Crisp in dotazione.

Accessorio necessario: **piatto crisp, maniglia per piatto crisp**

**DYNAMIC STEAM**

Per cuocere al vapore cibi come verdure o pesce, utilizzando la vaporiera in dotazione.

La fase di preparazione genera automaticamente il vapore portando a ebollizione l'acqua versata sul fondo della vaporiera. Questa fase può avere una durata variabile. In seguito, il forno procede alla cottura a vapore degli alimenti in base al tempo impostato.

I tempi di cottura indicativi sono:

- per vegetali freschi (250-500 g): 4-6 minuti;
- per vegetali surgelati (250-500 g): 5-7 minuti;
- per filetti di pesce (250-500 g): 4-6 minuti.

Accessorio necessario: **vaporiera**



## MANTENERE IN CALDO

Per mantenere caldi e croccanti cibi appena cotti, come carne, frittura o torte.

## AUTO AUTOMATICO

Con le funzioni automatiche è sufficiente specificare il peso o la quantità degli alimenti per ottenerne un risultato ottimale.



### DYNAMIC DEFROST

Per scongelare rapidamente carne, pollame, pesce, verdure e pane con un peso compreso tra 100g e 3 kg.

Si consiglia di disporre gli alimenti direttamente sul piatto rotante in vetro.



### SCONG. PANE CROCCANTE

Per scongelare e riscaldare velocemente panini, croissants e baguettes. Il forno calcolerà automaticamente i valori necessari per ottenere i migliori risultati possibili (tempo, potenza e metodo di cottura).

Accessorio necessario: piatto crisp, maniglia per piatto crisp



### RICETTE

**AUTO** Permette di scegliere tra diverse ricette automatiche con valori preimpostati per una cottura ottimale. Seguire le istruzioni fornite dal display per ottenere migliori risultati.

Nota: per ulteriori indicazioni, ricette e consigli utili per l'utilizzo di questa funzione, consultare e scaricare le istruzioni per l'uso da [docs.hotpoint.eu](http://docs.hotpoint.eu)



## IMPOSTAZIONI

Per modificare le impostazioni del forno (lingua, ora, volume del segnale acustico, luminosità, modalità eco).

Nota: quando è attivata la modalità ECO, la luminosità del display si abbassa dopo alcuni secondi per risparmiare energia. Il display si riattiva automaticamente dopo ogni interazione.

# PRIMO UTILIZZO

## 1. SELEZIONARE LA LINGUA

Alla prima accensione, è necessario impostare lingua e ora: il display mostra la lista delle lingue disponibili.

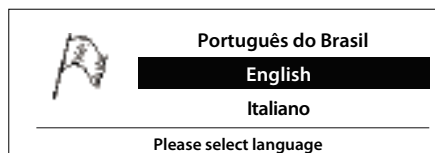

Utilizzare **▲** o **▼** per selezionare la lingua desiderata e premere **OK select** per confermare.

Nota: è possibile modificare in seguito la lingua accedendo alla voce del menu "Impostazioni".

## 2. IMPOSTARE L'ORA

Dopo aver selezionato la lingua, sarà necessario impostare l'ora corrente: sul display lampeggiano le ore 12:00.



Utilizzare **▲** o **▼** per impostare l'ora e premere **OK select** per confermare.

Nota: dopo una prolungata interruzione di corrente potrebbe essere necessario impostare nuovamente l'ora.

# USO QUOTIDIANO

## 1. SELEZIONARE UNA FUNZIONE

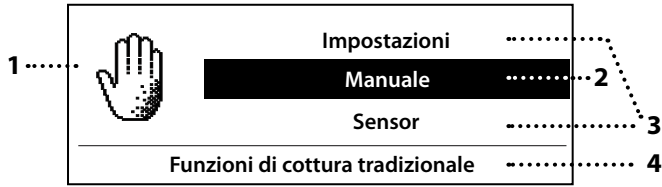

1. Simbolo della funzione selezionata
2. Funzione selezionata
3. Ulteriori funzioni disponibili
4. Descrizione della funzione selezionata

### ACCENDERE IL FORNO

Premere : il display mostra il menu principale.

### NAVIGAZIONE DEL MENU

Premere o per muoversi all'interno del menu principale ed evidenziare la voce selezionabile.

### SELEZIONARE UNA VOCE DEL MENU

Quando la voce desiderata è evidenziata sul display, premere per confermare la selezione e accedere alla schermata di impostazione (vedi in seguito) o alla lista delle funzioni.

### SELEZIONARE UNA FUNZIONE

Premere o per muoversi all'interno della lista proposta. Premere per confermare e accedere alla schermata di impostazione.

## 2. IMPOSTARE E AVVIARE LA FUNZIONE

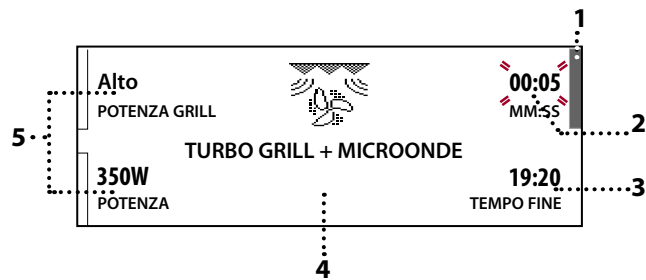

1. Cursore di selezione (evidenzia il valore selezionato)
2. Durata
3. Ora di fine funzione
4. Nome della funzione
5. Valori della funzione (potenza, temperatura, livello grill, peso o quantità, grado di cottura...)

### IMPOSTARE I VALORI

Inizialmente sarà possibile impostare i valori della funzione scelta secondo una sequenza proposta dal display: quando il valore lampeggia, utilizzare o per impostarlo e premere per confermare.

Se necessario, utilizzare o per spostare il cursore accanto al valore che si desidera modificare, quindi premere : il valore lampeggia.

Utilizzare o per modificare il valore e premere per confermare.

### AVVIARE LA FUNZIONE

In ogni momento, quando i valori corrispondono a quelli desiderati, premere per avviare la funzione.

Nota: i valori, quando possibile, possono essere modificati anche durante la cottura.

### . BLOCCO DI SICUREZZA

Questa funzione si attiva automaticamente per prevenire un avvio involontario del forno.

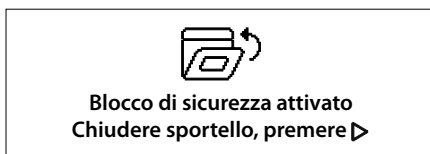

Aprire e chiudere la porta, quindi premere per avviare la funzione selezionata.

### . PAUSA

Per sospendere una funzione attiva, per esempio per mescolare o girare gli alimenti, è sufficiente aprire la porta.



Per riprendere, chiudere la porta e premere .

### . JET START





A forno spento, premere per avviare la cottura con la funzione microonde impostata alla potenza massima (900W) per 30 secondi.

Ogni pressione successiva del tasto aumenterà la durata di cottura di ulteriori 30 secondi.

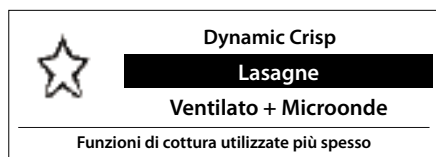
## . PREFERITI

Il forno compila automaticamente un elenco delle funzioni più utilizzate, sulla base delle abitudini d'uso. Accendere il forno con il tasto , quindi premere  per visualizzare la lista delle funzioni utilizzate più frequentemente.



Utilizzare  o  per selezionare la funzione desiderata, premere  per confermare e quindi modificare - se necessario - i valori secondo esigenza (i valori proposti sono quelli di base). Al termine, premere  per avviare la funzione.

## . CALORE RESIDUO

In molti casi, al termine di una cottura, il forno avvia automaticamente una procedura di raffreddamento, indicandone lo stato sul display.

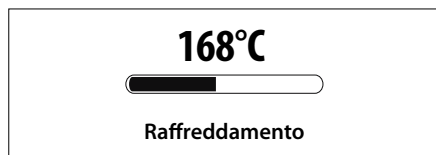





Per visualizzare l'orologio durante la procedura premere .

Nota: aprendo la porta, la procedura viene temporaneamente interrotta.

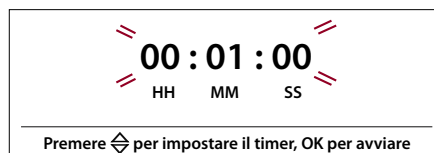
## . TIMER



Solo quando il forno è spento, è possibile utilizzare il display come contaminuti. Per riprendere la funzione, premere . sul display viene visualizzato il timer.































Premere  o  per impostare la durata desiderata e quindi premere nuovamente  per avviare il timer. Un segnale acustico avviserà del termine del conto alla rovescia.

















































Nota: il timer non attiva nessun ciclo di cottura. Per interrompere il timer in ogni momento, premere .

## . BLOCCO A CHIAVE

Per bloccare i tasti, tenere premuto contemporaneamente  e  per almeno 5 secondi. Per disattivare, ripetere la stessa procedura.

# TABELLA DI COTTURA

ALIMENTI	FUNZIONE	PRERISC.	TEMP. (°C) / LIVELLO GRILL	POTENZA (W)	DURATA	ACCESSORI
<b>Torte lievitate</b>		-	160 - 180	-	30-60	 
		-	160 - 180	90	25-50	 
<b>Torte ripiene</b> (cheese cake, strudel, torta di frutta)		Si	160-190	-	35-70	 
<b>Biscotti</b>		Si	170-180	-	10-20	
<b>Meringhe</b>		Si	100-120	-	40-50	
<b>Panini</b>		Si	210-220	-	10-12	
<b>Pagnotte</b>		Si	180-200	-	30-35	
<b>Pizza / Focaccia</b>		Si	190-220	-	20-40	
<b>Pizza</b> (0,4-0,5 Kg)		-	-	-	14-16	
<b>Torte salate</b> (torta di verdure, quiche lorraine)		Si	180-190	-	40-55	 
<b>Quiche lorraine</b> (1-1,2 Kg)		-	-	-	18-20	
<b>Lasagne / Pasta al forno</b>			Medio	350-500	15-40	 











ALIMENTI	FUNZIONE	PRERISC.	TEMP. (°C) / LIVELLO GRILL	POTENZA (W)	DURATA	ACCESSORI
<b>Arrosto di agnello / Vitello / Roastbeef</b> (1,3-1,5 kg)		-	170-180	-	70-80*	 
		-	160-180	160	50-70*	 
<b>Roastbeef media cottura</b> (1,3-1,5 Kg)		-	170-180	-	40-60*	 
<b>Pollo arrosto / Coniglio / Anatra</b> (intera 1-1,2 kg)		-	210-220	-	50-70*	 
		-	210-220	350	45-60*	 
<b>Pollo / Coniglio / Anatra</b> (filetti / pezzi)		-	Medio - Alto	350-500	20-40*	 
<b>Pezzi di pollo</b> (0,4-1 Kg)		-	-	-	12-18	
<b>Pesce al forno</b> (intero)		-	Alto	160-350	20-40	 
<b>Filetti di pesce / tranci</b>		Si	Alto	-	15-30*	 
<b>Verdure ripiene</b> (pomodori, zucchine, melanzane)		-	Medio	500-650	25-50	 
<b>Toast</b>		-	Alto	-	3-6	
<b>Salsicce / Spiedini / Costine / Hamburger</b>		-	Medio - Alto	-	20-40*	
<b>Salsicce / Hamburger</b> (0,2-1 Kg)		Si**	-	-	6-16	
<b>Patate al forno</b>		-	Medio	350-500	20-40*	 
<b>Patate a spicchi</b> (0,3-0,8 Kg)		-	-	-	10-20	
<b>Frutta cotta</b>		-	Medio	160-350	15-25	 
<b>Gratin di verdure</b>		-	Alto - Medio	-	15-25	 
<b>Verdure fritte</b> (0,3-0,8 Kg)		Si**	-	-	8-18	

\* Girare gli alimenti a metà cottura

\*\* Preriscaldare il piatto crisp per 3-5 minuti

 [www](http://www.docs.hotpoint.eu) Per ulteriori indicazioni, ricette e consigli utili per l'utilizzo delle funzioni automatiche consultare e scaricare le istruzioni per l'uso da **docs.hotpoint.eu**

 [www](http://www.docs.hotpoint.eu) Scaricare le istruzioni per l'uso da **docs.hotpoint.eu** per consultare la tabella delle ricette testate, compilata per gli istituti di valutazione secondo la norma IEC 60705 e IEC 60350.

FUNZIONI	Crisp	Grill	Grill + Microonde	Turbo Grill	Ventilato	Ventilato + Microonde
						
ACCESSORI	Piatto / contenitore adatto alle microonde e al calore 	Griglia bassa 	Piatto Crisp 	Teglia rettangolare 		

# PULIZIA

**Assicurarsi che l'apparecchio si sia raffreddato prima di eseguire ogni operazione.**

**Non utilizzare apparecchi a vapore.**

**Non usare pagliette metalliche, panni abrasivi e detersivi abrasivi o corrosivi che possano danneggiare le superfici.**

## SUPERFICI INTERNE ED ESTERNE

- Pulire le superfici con un panno in microfibra umido. Se molto sporche, aggiungere qualche goccia di detersivo neutro. Asciugare con un panno asciutto.
- Pulire i vetri della porta con detersivi liquidi specifici.
- A intervalli regolari o in caso di traboccamenti, togliere il piatto rotante e il suo supporto per pulire la base del forno, rimuovendo tutti i residui di cibo.
- Il grill non necessita di alcuna pulizia perché il calore intenso brucia direttamente lo sporco: attivare la funzione a intervalli regolari.

## ACCESSORI

- È possibile lavare in lavastoviglie tutti gli accessori ad eccezione del piatto Crisp.
- Il piatto Crisp deve essere pulito con acqua e un detersivo neutro. Per lo sporco più tenace, strofinare delicatamente con un panno. Far raffreddare il piatto Crisp prima di lavarlo.

# RISOLUZIONE DEI PROBLEMI



Scaricare le istruzioni per l'uso dal sito [docs.hotpoint.eu](http://docs.hotpoint.eu) per maggiori informazioni

Problema	Possibile causa	Soluzione
Il forno non funziona.	Interruzione di corrente elettrica. Disconnessione dalla rete principale.	Verificare che ci sia tensione in rete e che il forno sia collegato all'alimentazione elettrica. Spegner e riaccendere il forno e verificare se l'inconveniente persiste.
Il forno fa rumore anche se spento.	Ventola di raffreddamento attiva.	Aprire la porta o attendere la fine del raffreddamento.
Il display mostra la lettera "F" seguita da un numero.	Guasto software.	Contattare il più vicino Servizio Assistenza Clienti e specificare il numero che segue la lettera "F".

## DATI TECNICI

La scheda tecnica del prodotto con i dati del consumo energetico è scaricabile dal sito web [docs.hotpoint.eu](http://docs.hotpoint.eu)

## COME OTTENERE LE ISTRUZIONI PER L'USO

> Scaricare le Istruzioni per l'uso dal sito web [docs.hotpoint.eu](http://docs.hotpoint.eu) (è possibile utilizzare questo codice QR) specificando il codice prodotto.



> In alternativa, contattare il Servizio di Assistenza Clienti.

## CONTATTARE IL SERVIZIO ASSISTENZA CLIENTI

I contatti possono essere trovati sul manuale di garanzia. Quando si contatta il Servizio di Assistenza Clienti fornire i codici presenti sulla targhetta matricola del prodotto.

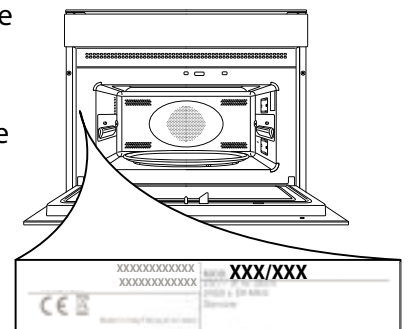



# GUIA DE CONSULTA DIÁRIA



## OBRIGADO POR ADQUIRIR UM PRODUTO HOTPOINT - ARISTON

Para receber mais informações e assistência, registre o seu produto em [www.hotpoint.eu/register](http://www.hotpoint.eu/register)



Pode transferir as Instruções de Segurança e o Guia de Utilização e Manutenção visitando o nosso website [docs.hotpoint.eu](http://docs.hotpoint.eu) e seguindo as instruções no verso do presente guia.



**Antes de utilizar o aparelho, leia atentamente o guia de Saúde e Segurança.**

## DESCRIÇÃO DO PRODUTO

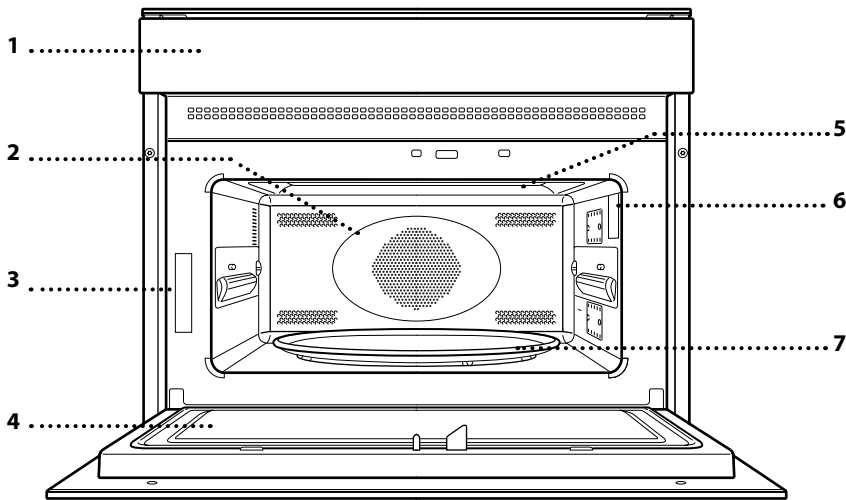

1. Painel de controlo
2. Resistência circular (invisível)
3. Placa de identificação (não remover)
4. Porta
5. Resistência superior/grelhador
6. Luz
7. Prato rotativo

## PAINEL DE CONTROLO

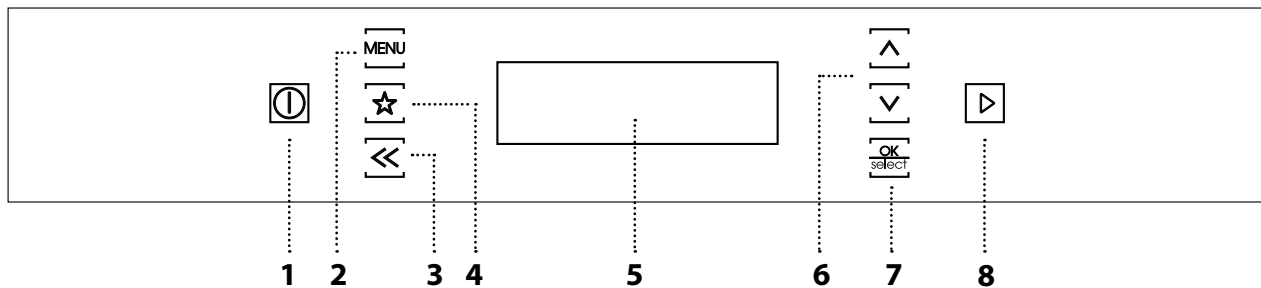

### 1. LIGAR/DESLIGAR

Para ligar e desligar o forno e parar uma função ativa.

### 2. MENU

Para aceder à lista de funções.

### 3. RETROCEDER

Para regressar ao menu anterior.

### 4. FAVORITOS

Para aceder à lista das funções mais utilizadas.

### 5. VISOR

### 6. BOTÕES DE NAVEGAÇÃO

Para percorrer a lista de funções, movendo o cursor, e para alterar as definições de uma função.

### 7. BOTÃO DE CONFIRMAÇÃO

Para confirmar a seleção de uma função ou um valor definido.

### 8. INICIAR

Para iniciar imediatamente uma função. Se o forno estiver desligado, ativa a função do microondas "Jet Start".

## PRATO ROTATIVO

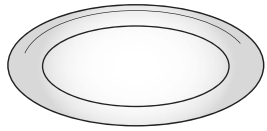

Colocado no respetivo suporte, o prato rotativo de vidro pode ser utilizado com todos os métodos de cozedura.

O prato rotativo tem sempre de ser utilizado como base

para outros recipientes ou acessórios, à exceção do tabuleiro de assar retangular.

## SUPORTE DO PRATO ROTATIVO

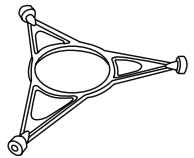

Utilize apenas o suporte para o prato rotativo de vidro. Não apoie outros acessórios no suporte.

## PRATO CRISP

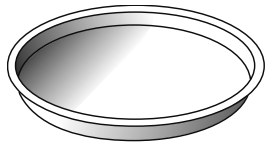

Para utilização exclusiva com a função "Dynamic Crisp". O prato Crisp tem sempre de ser posicionado no centro do prato rotativo de vidro e pode ser pré-aquecido quando estiver vazio,

utilizando a função especial exclusiva para este efeito. Coloque os alimentos diretamente no prato Crisp.

## MANÍPULO PARA O PRATO CRISP

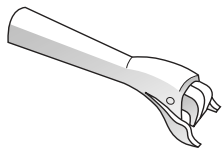

Útil para retirar o prato Crisp quente do forno.

## TABULEIRO DE ASSAR RETANGULAR

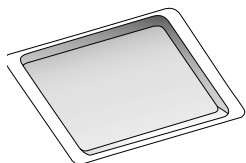

Utilize o tabuleiro de assar apenas com funções que permitam a cozedura de convexão; este nunca deve ser utilizado em combinação com a função de micro-ondas. Introduza o tabuleiro na

horizontal, apoiando-o no suporte do compartimento de cozedura.

Lembre-se: Não é necessário retirar o prato rotativo e o respetivo suporte quando utilizar o tabuleiro de assar retangular.

Lembre-se: O número de acessórios pode variar de acordo com o modelo adquirido. Pode adquirir separadamente outros acessórios no Serviço Pós-venda.

**Existem vários acessórios disponíveis no mercado. Antes de os comprar, certifique-se de que estes são adequados para serem utilizados no micro-ondas e que são resistentes às temperaturas do forno.**

**Os recipientes metálicos para alimentos ou bebidas nunca devem ser utilizados na função de micro-ondas.**

## GRELHA BAIXA

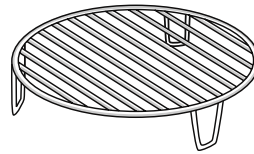

Permite posicionar os alimentos mais próximos do grelhador, para dourar o prato de forma ideal e permitir uma excelente circulação do ar quente. Coloque a grelha sobre o prato rotativo,

certificando-se de que esta não entra em contacto com outras superfícies.

## VAPORIZADOR

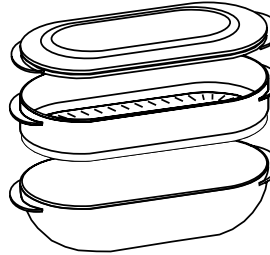

1 Para cozer alimentos a vapor, como peixe ou legumes, coloque-os no cesto (2) e deite água potável (100 ml) na parte inferior do vaporizador (3) de forma a obter a quantidade certa de vapor.

Para cozinhar alimentos como massa, arroz ou batatas, coloque-os diretamente na parte inferior do vaporizador (não é necessário o cesto) e junte a quantidade adequada de água potável para a quantidade de alimentos que pretende cozinhar.

Para obter os melhores resultados, tape o vaporizador com a tampa (1) fornecida.

Coloque sempre o vaporizador no prato rotativo de vidro e utilize-o apenas com as funções de cozedura adequadas ou com as funções de micro-ondas.

## TAMPA

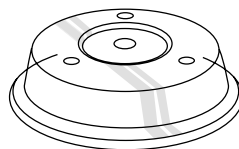

Útil para tapar alimentos enquanto estes cozinham ou aquecem no micro-ondas.

A tampa reduz os salpicos, mantém a humidade dos alimentos e também pode ser utilizada para criar dois níveis de cozedura.

Não é adequada para a utilização na cozedura de convecção ou com as funções do grelhador (incluindo "Dynamic Crisp").

# FUNÇÕES



Transfira o Guia de Utilização e Manutenção a partir do website [docs.hotpoint.eu](https://docs.hotpoint.eu) para obter mais informações



## MANUAL

### MICROONDAS

Para cozinhar rapidamente e aquecer alimentos ou bebidas.

POTÊNCIA	USO SUGERIDO
900 W	Aquecimento rápido de bebidas ou outros alimentos com elevado teor de água
750 W	Cozinhar legumes
650 W	Cozinhar carne e peixe
500 W	Cozinhar molhos para carne ou molhos que contenham queijo ou ovos. Terminar empadas ou gratinados de massa
350 W	Cozedura lenta. Perfeito para derreter manteiga ou chocolate
160 W	Descongelar alimentos congelados ou amolecer manteiga e queijo
90 W	Amolecer gelados

Acessórios recomendados: Tampa



### DYNAMIC CRISP

Para dar um tom dourado perfeito a um prato, tanto na parte superior como na parte inferior dos alimentos. Esta função só pode ser utilizada com o prato especial Crisp.

Acessórios necessários: Prato Crisp, manípulo para o prato Crisp



### GRELHADOR

Para dourar, grelhar e gratinar. Recomendamos que vire os alimentos durante a cozedura. Para obter os melhores resultados, pré-aqueça o grelhador durante 3-5 minutos.

Acessórios recomendados: grelha



### GRELHADOR + MICROONDAS

Para cozinhar rapidamente e para gratinar pratos, combinando as funções de micro-ondas e de grelhador.

Acessórios recomendados: grelha



### TURBO GRILL

Para obter resultados perfeitos, combinando as funções de grelhador e de convecção. Recomendamos que vire os alimentos durante a cozedura.

Acessórios recomendados: grelha



### TURBO GRILL + MICROONDAS

Para cozinhar rapidamente e dourar pratos, combinando as funções de micro-ondas, grelhador e forno de convecção.

Acessórios recomendados: grelha



### AR FORÇADO

Para cozinhar refeições de forma a obter resultados semelhantes ao de um forno convencional. O tabuleiro de assar ou outro recipiente para forno podem ser utilizados para cozinhar determinados alimentos.

Acessórios recomendados: Tabuleiro de assar retangular/grelha



### AR FORÇADO + MICROONDAS

Para preparar pratos de forno num curto período de tempo.

Acessórios recomendados: grelha



### AQUECIMENTO RÁPIDO

Para aquecer rapidamente o forno antes de um ciclo de cozedura.

Aguarde que a função termine antes de colocar alimentos no interior do forno.



### SENSOR

As funções do sensor adaptam-se de modo contínuo durante a cozedura, para que possa obter o resultado perfeito.

O tempo total não inclui as fases de preparação ou de pré-aquecimento.



### DYNAMIC REHEAT

Para aquecer refeições prontas congeladas ou à temperatura ambiente.

O forno calcula automaticamente os valores necessários para obter os melhores resultados no menor tempo possível. Coloque os alimentos numa travessa ou prato resistente ao calor e próprio para fornos micro-ondas.



### DYNAMIC CRISP

Para aquecer rapidamente e cozinhar alimentos congelados, permitindo obter um tom dourado e um toque estaladiço. Utilize apenas esta função com o prato Crisp fornecido.

Acessórios necessários: Prato Crisp, manípulo para o prato Crisp



### DYNAMIC STEAM

Para cozinhar alimentos a vapor, tais como legumes ou peixe, utilizando o vaporizador fornecido. A fase de preparação produz vapor automaticamente, fazendo com que a água colocada na parte inferior do vaporizador ferva. Os tempos desta fase podem variar. De seguida, o forno cozinha os alimentos a vapor de acordo com o tempo definido.

Alguns tempos indicativos de cozedura:

- legumes frescos (250-500 g): 4-6 minutos;
- legumes congelados (250-500 g): 5-7 minutos;
- filetes de peixe (250-500 g): 4-6 minutos.

Acessórios necessários: Vaporizador



## MANTER QUENTE

Para manter quentes e estaladiços os alimentos acabados de cozinhar, incluindo carne, fritos ou bolos.

## AUTO AUTOMÁTICO

Com as funções automáticas, basta selecionar o peso ou a quantidade de alimentos para obter os melhores resultados.



### DYNAMIC DEFROST

Para descongelar rapidamente carne, aves, peixe, legumes e pão com um peso entre 100 g e 3 kg. Os alimentos devem ser colocados diretamente no prato rotativo de vidro.



### DESC. PÃO ESTAL.

Para descongelar e aquecer rapidamente pães, croissants e baguetes. O forno calcula automaticamente os valores necessários para obter os melhores resultados (tempo, potência e método de cozedura).

Acessórios necessários: Prato Crisp, manípulo para o prato Crisp



### RECEITAS

**AUTO** Permite escolher entre uma seleção de receitas automáticas, com valores predefinidos, para uma cozedura perfeita. Para obter os melhores resultados, siga as instruções apresentadas no visor.

Lembre-se: Para mais informações, receitas e conselhos úteis sobre a utilização desta função, leia e transfira o Guia de Utilização e Manutenção de [docs.hotpoint.eu](http://docs.hotpoint.eu)



## DEFINIÇÕES

Para alterar as definições do forno (idioma, tempo, volume de sinais sonoros, luminosidade, modo ecológico).

Lembre-se: Quando o modo ecológico está ativo, a luminosidade do visor é reduzida após alguns segundos para poupar energia. O visor é reativado automaticamente quando algum dos botões é premido, etc.

# PRIMEIRA UTILIZAÇÃO

## 1. SELECIONE O IDIOMA

Ao ligar o aparelho pela primeira vez, terá de definir o idioma e a hora. O visor irá apresentar uma lista de idiomas disponíveis.

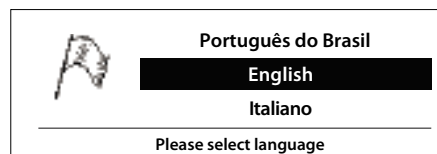

Utilize **▲** ou **▼** para selecionar o idioma que pretende e prima **OK select** para confirmar.

Lembre-se: O idioma também pode ser alterado mais tarde no item de menu "Definições".

## 2. ACERTAR A HORA

Após selecionar o idioma, terá de acertar a hora atual: "12:00" piscará no visor.

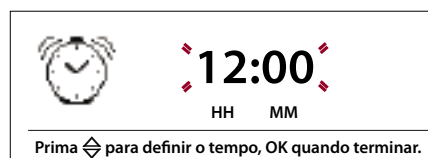

Utilize **▲** ou **▼** para acertar a hora e prima **OK select** para confirmar.

Lembre-se: Poderá ter de acertar novamente a hora após um longo corte de energia.

# UTILIZAÇÃO DIÁRIA

## 1. SELECIONAR UMA FUNÇÃO

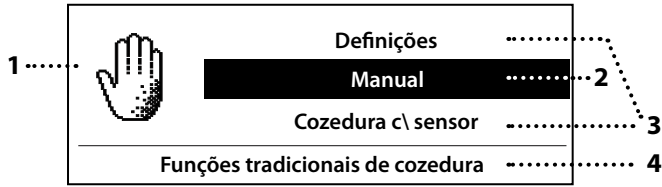

1. Símbolo da função selecionada
2. Função selecionada
3. Outras funções disponíveis
4. Descrição da função selecionada

### LIGAR O FORNO

Prima : O visor apresentará o menu principal.

### NAVEGAR NO MENU

Prima ou para navegar no menu principal e realçar o item que deseja selecionar.

### SELECIONAR UM ITEM DO MENU

Assim que o item que deseja selecionar estiver realçado no visor, prima para confirmar a seleção e aceder ao menu das definições (ver abaixo) ou à lista de funções.

### SELECIONAR UMA FUNÇÃO

Prima ou para navegar na lista apresentada. Prima para confirmar e aceder ao menu das definições.

## 2. DEFINIR E ATIVAR UMA FUNÇÃO



1. Cursor de seleção (destaca a definição selecionada)
2. Duração
3. Hora de fim da função
4. Nome da função
5. Definições para a função (potência, temperatura, nível do grelhador, peso ou quantidade, grau de cozedura desejado, etc.)

### APLICAR DEFINIÇÕES

Inicialmente, é possível definir os valores da função selecionada com base na sequência indicada no visor. Quando o valor estiver a piscar, utilize ou para definir o valor e prima para confirmar.

Se necessário, utilize ou para mover o cursor para junto do valor que deseja alterar e prima . O valor começará a piscar.

Utilize ou para alterar o valor e prima para confirmar.

### ATIVAR A FUNÇÃO

Quando as definições apresentadas forem aquelas que pretende, prima para ativar a função.

Lembre-se: Por vezes, é possível alterar alguns valores durante a cozedura.

## . BLOQUEIO DE SEGURANÇA

Esta função é ativada automaticamente para evitar que o forno seja ligado inadvertidamente.

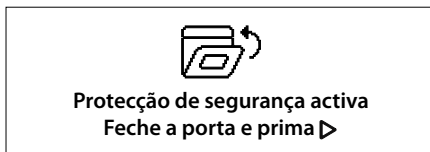

Abra e feche a porta e, de seguida, prima para iniciar a função selecionada.

## . PAUSA



Para colocar em pausa uma função ativa, por exemplo, para poder mexer os alimentos ou virá-los, basta abrir a porta. Para continuar, feche a porta e prima .

## . JET START



Quando o forno estiver desligado, prima para ativar a cozedura com a função de micro-ondas na potência máxima (900 W) durante 30 segundos.

Sempre que premir novamente o botão , o tempo de cozedura aumenta mais 30 segundos.

## . FAVORITOS

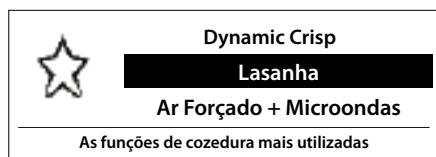
O forno irá criar automaticamente uma lista das funções mais utilizadas. Prima o botão  para ligar o forno e  para visualizar a lista de funções que utiliza mais frequentemente.



Utilize  ou  para selecionar a função que pretende, prima  para confirmar e altere, se necessário, as definições de acordo com as suas necessidades (as sugestões apresentam definições básicas).

Quando terminar, prima  para ativar a função.

## . CALOR RESIDUAL

Em muitos casos, quando os alimentos já estão cozinhados, o forno ativa um processo de arrefecimento automático, que será indicado no visor.







Para visualizar o relógio durante este processo, prima 

Lembre-se: Abrir a porta interrompe temporariamente o processo.

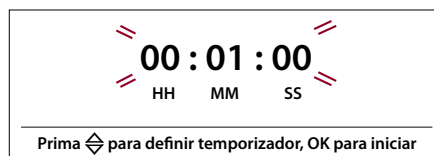
## . TEMPORIZADOR

Quando o forno é desligado, o visor pode ser utilizado como um temporizador. Para ativar a função, prima . O temporizador irá aparecer no visor.





Prima  ou  para definir o tempo pretendido e, de seguida, prima  para ativar o temporizador. Quando o temporizador terminar a contagem decrescente do tempo programado, ouvir-se-á um sinal sonoro.











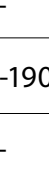

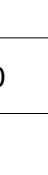



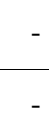

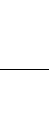

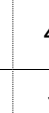
Lembre-se: O temporizador não ativa nenhum dos ciclos de cozedura.

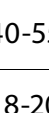

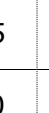

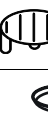















Para parar o temporizador em qualquer altura, prima .

## . PROTEÇÃO

Para bloquear o teclado, prima continuamente  e  em simultâneo durante, pelo menos, cinco segundos. Para desbloquear, repita o procedimento.

# TABELA DE COZEDURA

ALIMENTO	FUNÇÃO	PRÉ-AQUECIMENTO	TEMP. (°C)/NÍVEL DO GRELHADOR	POTÊNCIA (W)	DURAÇÃO	ACESSÓRIOS
Pães de ló		-	160-180	-	30-60	
		-	160-180	90	25-50	
Tartes recheadas (cheesecake, strudel, tarte de maçã)		Sim	160-190	-	35-70	
Biscoitos		Sim	170-180	-	10-20	
Merengues		Sim	100-120	-	40-50	
Pãezinhos		Sim	210-220	-	10-12	
Pão de forma		Sim	180-200	-	30-35	
Pizza / Tarte		Sim	190-220	-	20-40	
Pizza (0,4 - 0,5 kg)		-	-	-	14-16	
Tartes salgadas (tarte de legumes, quiche Lorraine)		Sim	180-190	-	40-55	
Quiche Lorraine (1 - 1,2 kg)		-	-	-	18-20	

ALIMENTO	FUNÇÃO	PRÉ-AQUECIMENTO	TEMP. (°C)/NÍVEL DO GRELHADOR	POTÊNCIA (W)	DURAÇÃO	ACESSÓRIOS
<b>Lasanha/massa gratinada</b>			Média	350-500	15-40	 
<b>Assado de borrego/vitela/ carne de vaca</b> (1,3-1,5 kg)		-	170-180	-	70-80*	 
		-	160-180	160	50-70*	 
<b>Carne de vaca assada, média</b> (1,3 - 1,5 kg)		-	170-180	-	40-60*	 
<b>Frango/coelho/pato assado</b> (inteiro 1-1,2 kg)		-	210-220	-	50-70*	 
		-	210-220	350	45-60*	 
<b>Frango/Coelho/Pato</b> (filetes/pedaços)		-	Médio - Alto	350-500	20-40*	 
<b>Pedaços de frango</b> (0,4-1 kg)		-	-	-	12-18	
<b>Peixe inteiro assado</b> (inteiro)		-	Alta	160-350	20-40	 
<b>Filetes/postas de peixe</b>		Sim	Alto	-	15-30*	 
<b>Legumes recheados</b> (tomates, curgetes, beringelas)		-	Média	500-650	25-50	 
<b>Tostas</b>		-	Alto	-	3-6	
<b>Salsichas/espetadas/ costeletas/hambúrgueres</b>		-	Médio - Alto	-	20-40*	
<b>Salsichas/hambúrgueres</b> (0,2-1 kg)		Sim**	-	-	6-16	
<b>Batatas assadas</b>		-	Média	350-500	20-40*	 
<b>Batatas fatiadas</b> (0,3-0,8 kg)		-	-	-	10-20	
<b>Fruta assada</b>		-	Média	160-350	15-25	 
<b>Gratinado de legumes</b>		-	Alto - médio	-	15-25	 
<b>Legumes fritos</b> (0,3-0,8 kg)		Sim**	-	-	8-18	

\* Vire o alimento a meio da cozedura

\*\* Pré-aqueça o prato Crisp durante 3-5 minutos

 [www](http://www.docs.hotpoint.eu) Para mais informações, receitas e conselhos úteis sobre a utilização das funções automáticas, leia e transfira o Guia de Utilização e Manutenção de **docs.hotpoint.eu**

 [www](http://www.docs.hotpoint.eu) Transfira o Guia de Utilização e Manutenção em **docs.hotpoint.eu** para consultar a tabela de receitas testadas, compiladas para as autoridades de certificação de acordo com as normas IEC 60705 e IEC 60350.

FUNÇÕES	Crisp 	Grelhador 	Grelhador + Microondas 	Turbo Grill 	Ar forçado 	Ar Forçado + Microondas 
ACESSÓRIOS	Prato resistente ao calor/ recipiente adequado para utilização no micro-ondas 	GRELHA BAIXA 		Prato Crisp 	TABULEIRO DE ASSAR RETANGULAR 	

# LIMPEZA

**Assegure-se de que o aparelho arrefece antes de executar qualquer operação de manutenção ou limpeza.**

**Não utilize aparelhos de limpeza a vapor.**

**Não utilize palha de aço, esfregões abrasivos ou produtos de limpeza abrasivos/corrosivos, uma vez que estes podem danificar as superfícies do aparelho.**

## SUPERFÍCIES INTERIOR E EXTERIOR

- Limpe as superfícies com um pano de microfibra húmido. Se estiverem muito sujas, acrescente alguns pingos de detergente com PH neutro. Termine a limpeza com um pano seco.
- Limpe o vidro da porta com um detergente líquido adequado.
- Periodicamente, ou quando houver derrames, retire o prato rotativo e o respetivo suporte para limpar o fundo do forno, retirando todos os restos de alimentos.
- O grelhador não precisa de ser limpo, uma vez que o calor intenso queima qualquer sujidade. Utilize esta função regularmente.

## ACESSÓRIOS

- Todos os acessórios podem ser lavados na máquina de lavar louça, exceto o prato Crisp.
- O prato Crisp deve ser lavado com água e um detergente suave. Para sujidade difícil, esfregue suavemente com um pano. Deixe sempre que o prato Crisp arrefeça antes de o limpar.

# RESOLUÇÃO DE PROBLEMAS



Transfira o Guia de Utilização e Manutenção a partir do website **docs.hotpoint.eu** para obter mais informações

Problema	Causa possível	Solução
O forno não está a funcionar.	Corte de energia. Desconexão da rede elétrica.	Verifique se existe energia elétrica proveniente da rede e se o forno está ligado à tomada elétrica. Desligue e volte a ligar o forno, para verificar se o problema ficou resolvido.
O forno emite ruídos, mesmo quando está desligado.	Ventilador de refrigeração ativado.	Abra a porta ou aguarde que o processo de arrefecimento esteja concluído.
O visor apresenta a letra "F", seguida de um número.	Falha de software.	Contacte o seu Serviço Técnico de Pós-Venda mais próximo e indique o número que acompanha a letra "F".

## FICHA DE PRODUTO

 A ficha do produto, incluindo os dados energéticos para este aparelho, pode ser transferida a partir do website **docs.hotpoint.eu**

## COMO OBTER O GUIA DE UTILIZAÇÃO E MANUTENÇÃO

>  Transfira o Guia de Utilização e Manutenção a partir do nosso website **docs.hotpoint.eu** (pode utilizar este código QR), especificando o código comercial do produto.



> Em alternativa, contacte o nosso Serviço Pós-Venda.

## CONTACTAR O NOSSO SERVIÇO PÓS-VENDA

Pode encontrar os nossos contactos no manual de garantia. Ao contactar o nosso Serviço Pós-Venda, indique os códigos fornecidos na placa de identificação do seu produto.

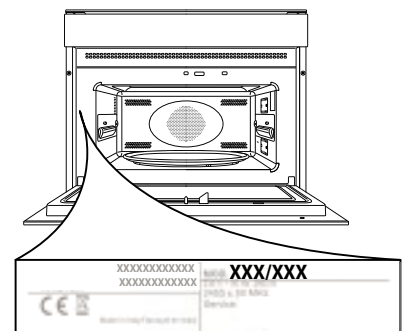

400011691309

