

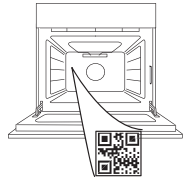

THANK YOU FOR BUYING A HOTPOINT-ARISTON PRODUCT

In order to receive a more complete assistance, please register your product on www.register10.eu

PLEASE SCAN THE QR CODE ON YOUR APPLIANCE IN ORDER TO REACH MORE INFORMATION



Before using the appliance carefully read the Safety Instruction.

PRODUCT DESCRIPTION

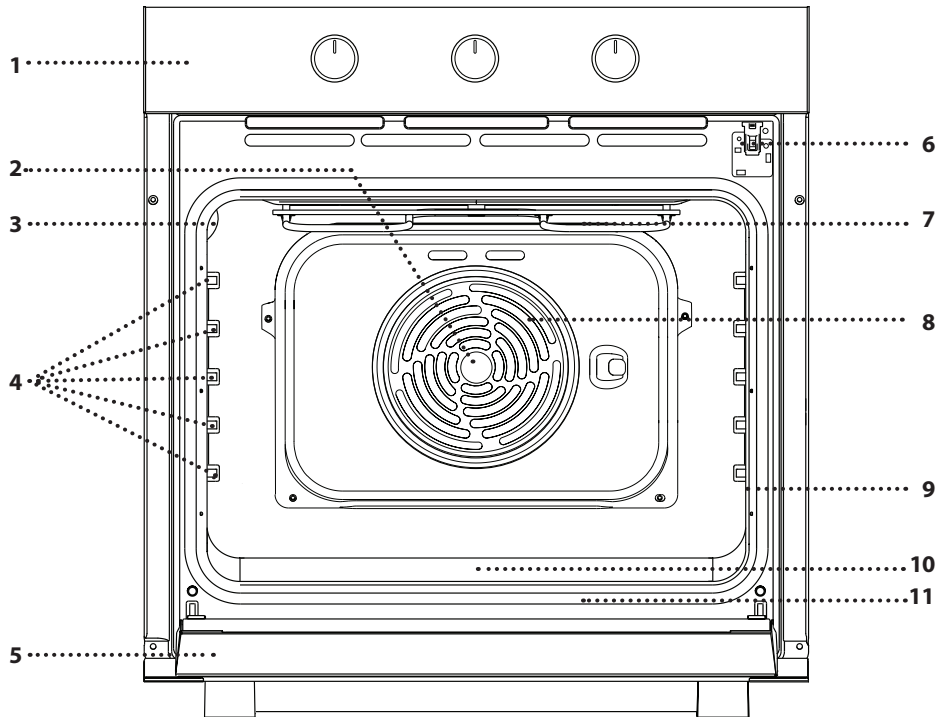

- 1. Control panel
- 2. Fan
- 3. Lamp
- 4. Shelf guides (the level is indicated on the wall of the cooking compartment)
- 5. Door
- 6. Door lock (locks the door while automatic cleaning is in progress and afterwards)
- 7. Upper heating element/grill
- 8. Circular heating element (not visible)
- 9. Identification plate (do not remove)
- 10. Embossing for drinking water
- 11. Bottom heating element (not visible)

CONTROL PANEL DESCRIPTION

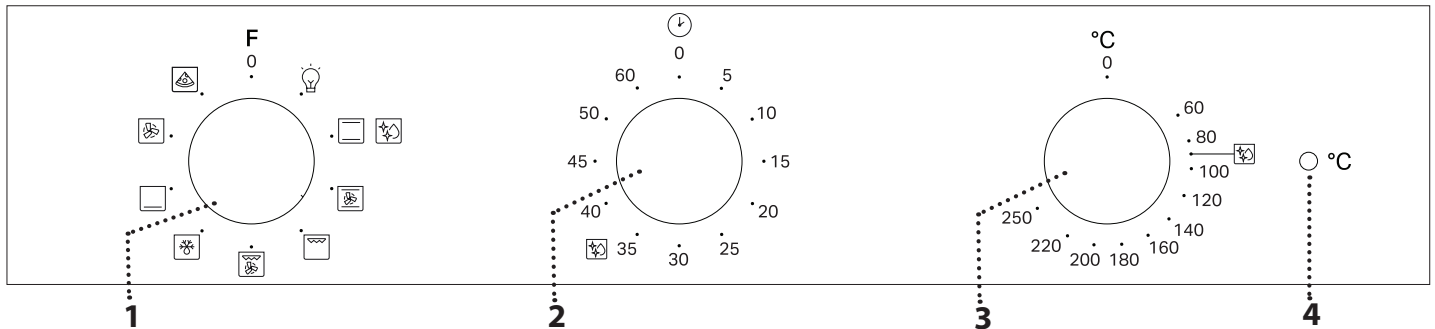

1. SELECTION KNOB

For switching the oven on by selecting a function. Turn to the 0 position to switch the oven off.

2. TIMER KNOB

Useful as a timer.

3. THERMOSTAT KNOB

Turn to select a desired temperature, activating the selected function.

4. LED THERMOSTAT/PREHEATING

Switches on during the heating process. Switches off once the desired temperature reached.

Please note: Type of knob may vary from model type. If the knobs are push-activated, push down on the center of the knob to release it from seating.

ACCESSORIES

WIRE SHELF

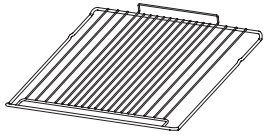

Use to cook food or as a support for pans, cake tins and other ovenproof items of cookware.

DRIP TRAY *

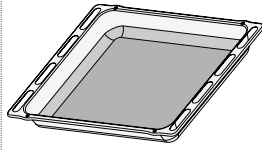

Use as an oven tray for cooking meat, fish, vegetables, focaccia, etc. or position underneath the wire shelf to collect cooking juices.

BAKING TRAY *

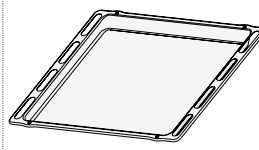

Use for cooking all bread and pastry products, but also for roasts, fish en papillote, etc.

SLIDING RUNNERS *

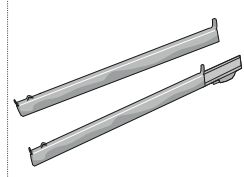

To facilitate inserting or removing accessories.

* Available only on certain models

The number and the type of accessories may vary depending on which model is purchased.

Other accessories can be purchased separately from the After-sales Service.

INSERTING THE WIRE SHELF AND OTHER ACCESSORIES

Insert the wire shelf onto the level you require by holding it tilted slightly upwards and resting the raised rear side (pointing upwards) down first.

Then slide it horizontally along the runners as far as possible.

Other accessories, like the baking tray, are to be inserted horizontally, letting them slide on the runners.

SLIDING SHELVES AND SHELF GUIDES

Before using the oven remove the protective tape [a] and then remove the protective foil [b] from the sliding runners.

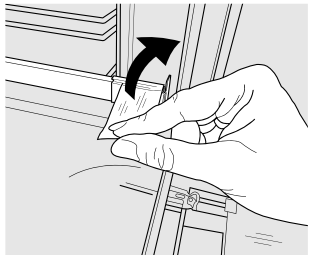

[a]

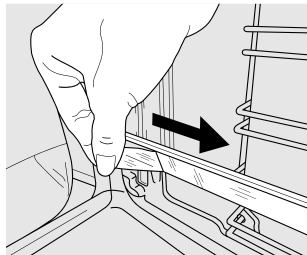

[b]

REMOVING THE SLIDING RUNNERS [c]

Pull the lower part of the sliding runner to uncouple the lower hooks (1) and pull the sliding runners upwards, removing them from the upper hooks (2).

REFITTING THE SLIDING RUNNERS [d]

Hook the upper hooks on the shelf guides (1) then press the lower part of the sliding runners against the shelf guides, until the lower hooks are clicking (2).

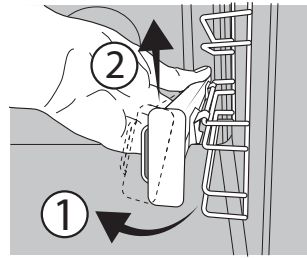

[c]

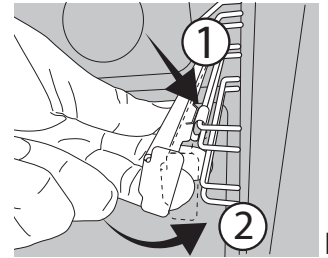

[d]

REMOVING AND REFITTING THE SHELF GUIDES

1. To remove the shelf guides, firmly grip the external part of the guide, and pull it towards you to extract the support and the two internal pins from the lodging.
2. To reposition the shelf guides, position them near the cavity and initially insert the two pins into their lodgings. Next, position the external part near its lodging, insert the support, and firmly press towards the wall of the cavity to make sure the shelf guide is properly secured.

FIRST TIME USE

A new oven may release odours that have been left behind during manufacturing: this is completely normal.

Before starting to cook food, we therefore recommend heating the oven with it empty in order to remove any possible odours.

Remove any protective cardboard or transparent film from the oven and remove any accessories from inside it.

Heat the oven to 250 °C for about one hour. The oven must be empty during this time.

Please note: It is advisable to air the room after using the appliance for the first time.

FUNCTIONS



OFF

For switching off the oven.



LIGHT

For switching on the light in the compartment



CONVENTIONAL

For cooking any kind of dish on one shelf only.



DIAMOND CLEAN

The action of the steam released during this special low-temperature cleaning cycle allows dirt and food residues to be removed with ease. Pour 100-120 ml of drinking water on the bottom of the oven then turn the selection knob and the thermostat knob to the  icon. It is best to use the function for 35 minutes.

Activate the function when the oven is cold and let it cool down for 15 minutes once the cycle ends. The position of the icon does not correspond to the temperature reached during the cleaning cycle.



CONVECTION BAKE

For cooking meat, baking salty cakes on a single shelf. This function can also be used for cooking on two shelves. Switch the position of the dishes to cook food more evenly.



GRILL

For grilling steaks, kebabs and sausages, cooking vegetables au gratin or toasting bread.

When grilling meat, we recommend using a dripping pan to collect the cooking juices: position the pan on any of the levels below the wire shelf and add 200 ml of drinking water.



TURBO GRILL

For roasting large joints of meat (legs, roast beef, chicken). We recommend using a dripping pan to collect the cooking juices: position the pan on any of the levels below the wire shelf and add 200 ml of drinking water.



DEFROST

For defrosting food more quickly. To activate the defrosting function turn the selection knob to the icon  then turn the thermostat knob clockwise to any temperature. This function does not heat so any temperature can be used. When defrosting is completed turn the two controls to the 0 position.



BOTTOM HEATING

Use this function to brown the bottom of the dishes. It is advisable to place the food on the 1st/2nd level. The function can also be used for slow cooking, such as vegetables and meat stews; in this case, use the 3rd level. The oven does not have to be preheated.



FORCED AIR

For cooking different foods that require the same cooking temperature on several shelves (maximum three) at the same time. This function can be used to cook different foods without odours being transferred from one food to another.



PIZZA

For baking different types and sizes of pizza and bread. It is a good idea to swap the position of the baking trays halfway through cooking.

DAILY USE

1. SELECT A FUNCTION

To select a function, turn the *selection knob* to the symbol for the function you require.

2. ACTIVATE A FUNCTION

MANUAL

Turn the selector knob to the required function. The oven light switches on. Turn the thermostat knob clockwise to the required temperature. At the end of cooking, to switch off the oven, turn the selection knob and the thermostat knob to 0.

DIAMOND CLEAN

To activate the "Diamond Clean" cleaning function, pour 100 - 120 ml of drinking water into the bottom of the oven, then turn all the 3 knobs (selection knob, timer knob, thermostat knob) to icon . The function will activate automatically and its duration is 35 minutes.

3. PREHEATING

Once the function has been activated, the LED thermostat will switch on signalling that the preheating process has begun. At the end of this process, the LED thermostat switches off indicating that the oven has

reached the set temperature: at this point, place the food inside and proceed with cooking.

Please note: Placing the food in the oven before preheating has finished may have an adverse effect on the final cooking result.

4. SETTING THE TIMER

The timer knob can be used to set a cooking time of between 1 and 60 minutes. To set cooking time, after selecting the required cooking function, turn the knob right round (360°) in a clockwise direction and then turn it back in the opposite direction to the desired cooking duration.

. NOTES

- Do not cover the inside of the oven with aluminum foil.
- Never drag pots or pans across the bottom of the oven as this could damage the enamel coating.
- Do not place heavy weights on the door and do not hold on to the door.





















































































. ENERGY EFFICIENCY NOTES











- Take advantage of residual heat: turn off the oven











5/10 minutes before the end of cooking to use the remaining heat.

- Keep the door closed: if possible, avoid opening the oven door during cooking, as this lets heat escape.
- Cook larger portions: use the oven mainly for bigger dishes (e.g., meat over 1 kg) or higher servings, to make the most of the energy used.
- Clean the door seal regularly: a clean seal prevents heat loss and ensures efficient cooking.
- Preheat only when needed: preheat the oven only if the recipe or cooking table recommends it.
- Choose dark baking trays: dark trays absorb heat better, improving cooking efficiency.
- Plan your cooking: prepare multiple dishes in sequence to use residual heat and avoid extra preheating.
- Select the energy-saving program: use the dedicated ECO program for lower energy consumption. Refer to cooking table for additional inputs.
- Remove unused accessories: take out trays or racks you don't need to improve heat circulation efficiency and to lower down the thermal capacity of the product.

COOKING TABLE

RECIPE	FUNCTION	PREHEAT	TEMPERATURE (°C)	DURATION (Min)	LEVEL AND ACCESSORIES
Leavened cakes		Yes	150 - 170	30 - 90	2 
		Yes	160 - 180	30 - 90	4 1  
Filled cake (cheese cake, strudel, fruit pie)		Yes	160 - 200	35 - 90	2 
		Yes	160 - 200	40 - 90	4 2  
Biscuits/tartlets		Yes	160 - 180	20 - 45	3 
		Yes	150 - 170	20 - 45	4 2  
		Yes	150 - 170	20 - 45	5 3 1   
Choux buns		Yes	180 - 210	30 - 40	3 
		Yes	180 - 200	35 - 45	4 2  
Meringues		Yes	90	150 - 200	3 
		Yes	90	140 - 200	4 2  
		Yes	90	140 - 200	5 3 1   
Pizza / foccacia		Yes	190 - 250	15 - 50	1/2 
		Yes	190 - 250	20 - 50	4 2  
Small bread (80g)		Yes	180 - 200	30 - 45	2 
Bread loaf (500g)		Yes	180	50 - 70	1/2 
Bread		Yes	180 - 200	30 - 80	4 2  
Frozen pizza		Yes	250	10 - 20	3 
		Yes	230 - 250	10 - 25	4 2  
Salty cakes (vegetable pie, quiche)		Yes	180 - 200	30 - 45	2 
		Yes	180 - 200	35 - 50	4 2  
		Yes	180 - 200	35 - 50	5 3 1   
Vols-au-vents / puff pastry crackers		-	190 - 200	20 - 30	3 
		-	180 - 190	20 - 40	4 2  
		-	180 - 190	20 - 40	5 3 1   
Lasagne / baked pasta / cannelloni / flans		Yes	190 - 200	45 - 65	2 
Lamb / veal / beef / pork 1 kg		Yes	190 - 200	80 - 110	3 
Roast pork with crackling 2 kg		Yes	180 - 190	110 - 150	2 
Chicken/rabbit/duck 1 kg		Yes	200 - 230	50 - 100	2 
Turkey / goose 3 kg		-	190 - 200	100 - 160	2 
Baked fish/en papillote (fillets, whole)		Yes	170 - 190	30 - 50	2 
Stuffed vegetables (tomatoes, courgettes, aubergines)		Yes	180 - 200	50 - 70	2 
Toasted bread		-	250	2 - 6	5 











FUNCTIONS	 Conventional	 Grill	 Turbo Grill	 Pizza	 Forced Air
ACCESSORIES	 Wire shelf	 Baking dish or cake tin on the wire shelf	 Baking tray/Drip tray or Baking dish on the wire shelf	 Drip tray / Baking tray	 Drip tray / Baking tray with 200 ml of water

RECIPE	FUNCTION	PREHEAT	TEMPERATURE (°C)	DURATION (Min)	LEVEL AND ACCESSORIES
Fish fillets/slices		-	230 - 250	20 - 30*	4 3
Sausages/kebabs/spare ribs/ hamburgers		-	250	15 - 30*	5 4
Roast chicken 1-1,3 kg		Yes	200 - 220	55 - 70**	2 1
Roast beef rare 1 kg		Yes	200 - 210	35 - 50**	3
Leg of lamb/knuckle		Yes	200 - 210	60 - 90**	3
Roast potatoes		Yes	200 - 210	35 - 55**	3
Vegetable gratin		-	200 - 210	25 - 55	3
Meat and potatoes		Yes	190 - 200	45 - 100***	4 1
Fish and vegetables		Yes	180	30 - 50***	4 1
Lasagne and meat		Yes	200	50 - 100***	4 1
Complete meal: fruit tart (level 5) / lasagne (level 3) / meat (level 1)		Yes	180 - 190	40 - 120***	5 3 1

* Turn food halfway through cooking

** Turn food two thirds of the way through cooking (if necessary).

*** Estimated length of time: dishes can be removed from the oven at different times depending on personal preference.

FUNCTIONS					
	Conventional	Grill	Turbo Grill	Pizza	Forced Air
ACCESSORIES					
	Wire shelf	Baking dish or cake tin on the wire shelf	Baking tray/Drip tray or Baking dish on the wire shelf	Drip tray / Baking tray	Drip tray / Baking tray with 200 ml of water

CLEANING AND MAINTENANCE

Make sure that the oven has cooled down before carrying out any maintenance or cleaning. Do not use steam cleaners. Do not use wire wool, abrasive scourers or abrasive/corrosive cleaning agents, as these could

damage the surfaces of the appliance. Wear protective gloves. The oven must be disconnected from the mains before carrying out any kind of maintenance work.

It is possible to use a standard oven cleaner to help soften and remove residues, making manual cleaning of the cavity and accessories easier.

EXTERIOR SURFACES

Clean the surfaces with a damp microfibre cloth. If they are very dirty, add a few drops of pH-neutral detergent. Finish off with a dry cloth.

Do not use corrosive or abrasive detergents. If any of these products inadvertently comes into contact with the surfaces of the appliance, clean immediately with a damp microfibre cloth.

INTERIOR SURFACES

- After every use, leave the oven to cool and then clean it, preferably while it is still warm, to remove any deposits or stains caused by food residues. To dry any condensation that has formed as a result

of cooking foods with a high water content, leave the oven to cool completely and then wipe it with a cloth or sponge.

- The door can be easily removed and refitted to facilitate cleaning of the glass.
- Clean the glass in the door with a suitable liquid detergent.

ACCESSORIES

Soak the accessories in a washing-up liquid solution after use, handling them with oven gloves if they are still hot. Food residues can be removed using a washing-up brush or a sponge.

REMOVING AND REFITTING THE DOOR

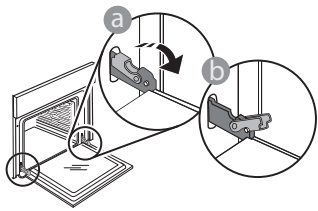

1. To remove the door, open it fully and lower the catches until they are in the unlock position.

3. Refit the door by moving it towards the oven, aligning the hooks of the hinges with their seating and securing the upper part onto its seating.

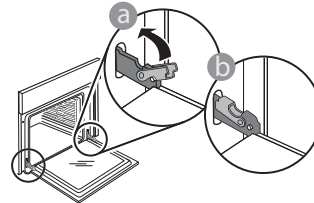

4. Lower the door and then open it fully. Lower the catches into their original position: Make sure that you lower them down completely.

Apply gentle pressure to check that the catches are in the correct position.

5. Try closing the door and check to make sure that it lines up with the control panel. If it does not, repeat the steps above: The door could become damaged if it does not work properly.

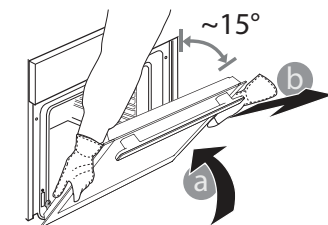

2. Close the door as much as you can. Take a firm hold of the door with both hands – do not hold it by the handle. Simply remove the door by continuing to close it while pulling it upwards at the same time until it is

released from its seating. Put the door to one side, resting it on a soft surface.

LOWER THE UPPER HEATING ELEMENT

1. Extract the heating element from its seating, then lower it.

2. To return the heating element to its position, lift it up, pull it slightly towards you and make sure that the tab support is in its proper seating.

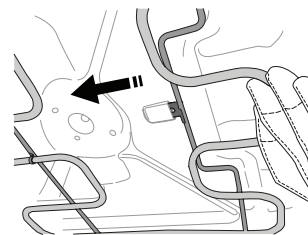
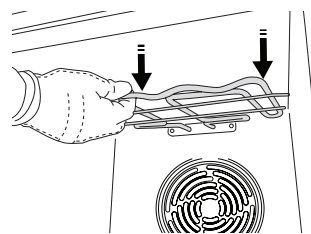
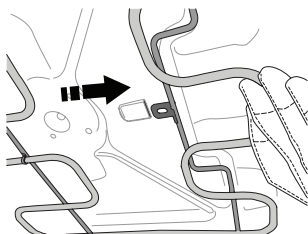

CLEANING OF THE DOOR GLASSES

1. After removing the door and resting it on a soft surface with the handle downwards, simultaneously press the two retaining clips and remove the upper edge of the door by pulling it towards you.

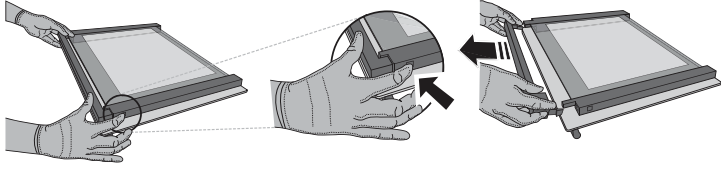

2. Lift and firmly hold the inner glass with both hands, remove it and place it on a soft surface before cleaning it.

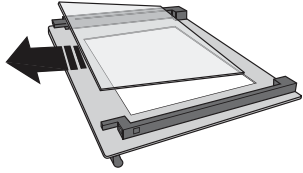

3. Refit the intermediate pane (marked with "1R") before refitting the inside pane: To position the panes of glass correctly, make sure that the "R" mark can be seen in the left-hand corner. First insert the long side of the glass marked "R" into the support seats, then lower it into position. Repeat this procedure for both panes of glass.

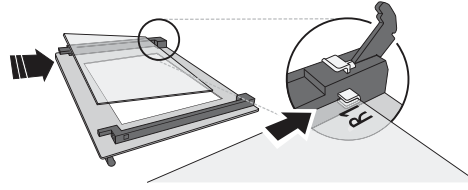

4. Refit the upper edge: A click will indicate correct positioning. Make sure the seal is secure before refitting the door.

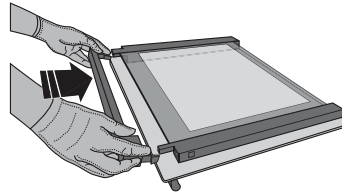

REPLACING THE LAMP

1. Disconnect the oven from the power supply.
2. Unscrew the cover from the light, replace the bulb and screw the cover back on the light.
3. Reconnect the oven to the power supply.

Please note: Use 25 W/230 V type G9, T300 °C halogen lamps. The bulb used in the product is specifically designed for domestic appliances and is not suitable for general room lighting within the home (EC Regulation 244/2009).

Light bulbs are available from our After-sales Service. - Do not handle bulbs with your bare hands as your fingerprints could damage them. Do not use the oven until the light cover has been refitted.

TROUBLESHOOTING

PROBLEM	POSSIBLE CAUSE	SOLUTION
The oven is not working.	Power cut. Disconnection from the mains.	Check for the presence of mains electrical power and whether the oven is connected to the electricity supply. Turn off the oven and restart it to see if the fault persists.

Policies, standard documentation and additional product information can be found by:

- Using the QR code in your appliance
- Visiting our website docs.hotpoint.eu
- Alternatively, **contact our After-sales Service** (See phone number in the warranty booklet). When contacting our After-sales Service, please state the codes provided on your product's identification plate.

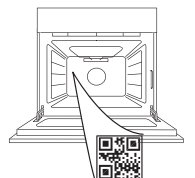



GRAZIE PER AVERE ACQUISTATO UN PRODOTTO HOTPOINT-ARISTON

Per ricevere un'assistenza più completa, registrare il prodotto su www.register10.eu

SCANSIONARE IL CODICE QR SUL PROPRIO APPARECCHIO PER OTTENERE MAGGIORI INFORMAZIONI

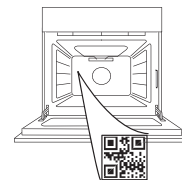

Prima di utilizzare l'apparecchio leggere attentamente le istruzioni di sicurezza.

DESCRIZIONE DEL PRODOTTO

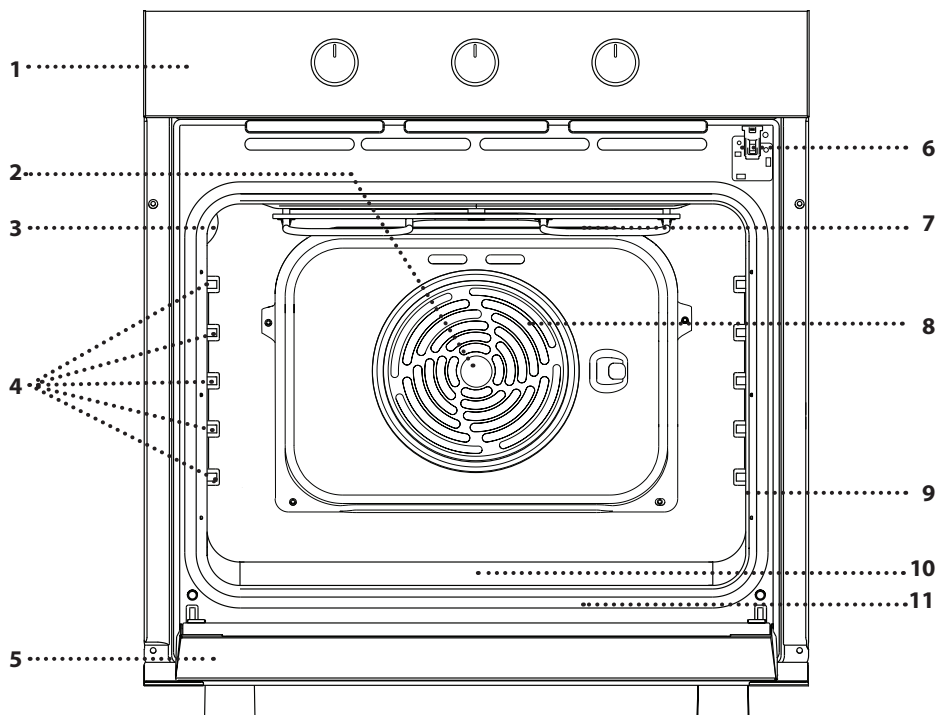

1. Pannello comandi
2. Ventola
3. Luce
4. Griglie laterali (il livello è indicato sulla parete della cavità)
5. Porta
6. Blocco serratura (blocca la porta durante e dopo la pulizia automatica)
7. Resistenza superiore / grill
8. Resistenza circolare (non visibile)
9. Targhetta matricola (da non rimuovere)
10. Cavità per l'acqua potabile
11. Resistenza inferiore (non visibile)

DESCRIZIONE DEL PANNELLO COMANDI

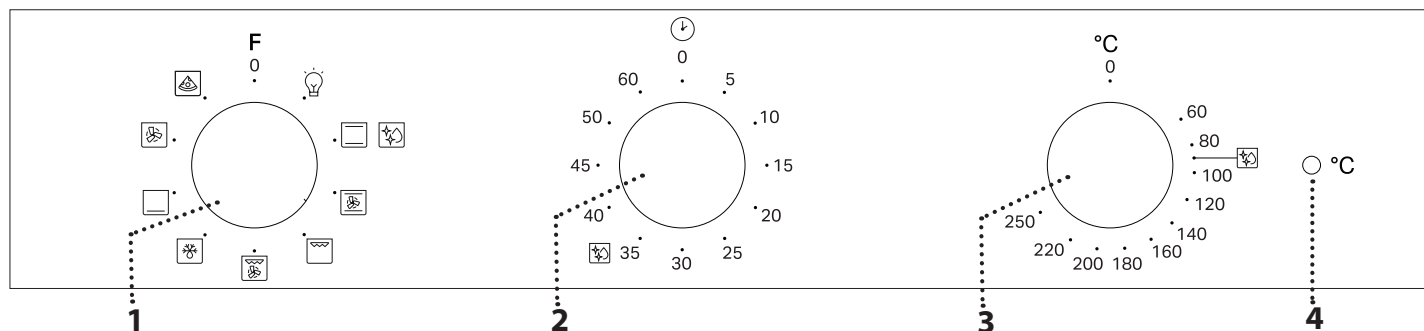

1. MANOPOLA DI SELEZIONE

Per accendere il forno selezionando una funzione. Ruotare in posizione 0 per spegnere il forno.

2. MANOPOLA DEL TIMER

Utilizzabile come timer.

3. MANOPOLA TERMOSTATO

Ruotare per selezionare la temperatura e attivare la funzione desiderata.

4. SPIA TERMOSTATO / PRERISCALDAMENTO

Si accende durante la fase di riscaldamento. Si spegne al raggiungimento della temperatura desiderata.

Note: Il tipo di manopola può variare a seconda del modello. Se le manopole sono attivate a pressione, spingere verso il basso il centro della manopola per sbloccarla dalla relativa sede.

ACCESSORI

GRIGLIA

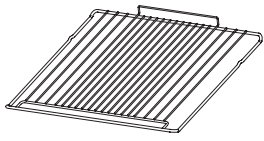

Utilizzare per cuocere gli alimenti o come supporto per teglie, tortiere e altre pentole da forno.

LECCARDA*

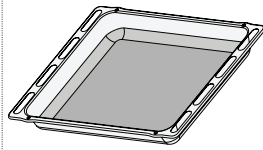

Utilizzare come teglia da forno per cucinare carne, pesce, verdure, focacce, ecc. o posizionare sotto la griglia per raccogliere i succhi di cottura.

PIASTRA DOLCI *

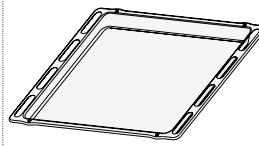

Utilizzare per la cottura di tutti i prodotti di panetteria e pasticceria, ma anche per arrosti, pesce en papillote, ecc.

GUIDE DI SCORRIMENTO *

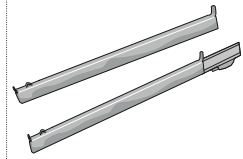

Per facilitare l'inserimento o la rimozione degli accessori.

* Disponibile solo su alcuni modelli

Il numero e il tipo di accessori possono variare a seconda del modello acquistato.

È possibile acquistare separatamente altri accessori presso il Servizio Assistenza Tecnica.

INSERIRE LA GRIGLIA E GLI ALTRI ACCESSORI

Inserire la griglia tenendola leggermente inclinata verso l'alto, appoggiando dapprima il lato posteriore rialzato - orientato verso l'alto - sul livello desiderato.

In seguito, farla scivolare orizzontalmente sulle guide fino a fine corsa.

Gli altri accessori, per esempio la teglia, vanno inseriti orizzontalmente facendoli scivolare sulle guide.

GRIGLIE SCORREVOLI E GUIDE LATERALI

Prima di utilizzare il forno rimuovere il nastro di protezione [a] e successivamente rimuovere la pellicola protettiva [b] dalle guide di scorrimento.

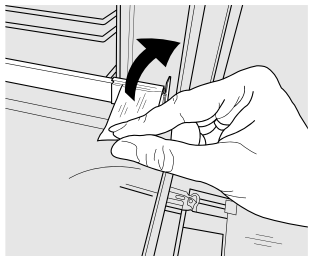

[a]

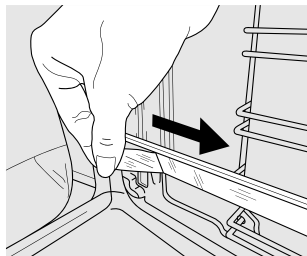

[b]

RIMOZIONE DELLE GUIDE DI SCORRIMENTO [c]

Tirare la parte inferiore della guida di scorrimento per sganciare i ganci inferiori (1) e tirare le guide di scorrimento verso l'alto, rimuovendole dai ganci superiori (2).

PRIMO UTILIZZO

Un nuovo forno può rilasciare degli odori dovuti alla lavorazione di fabbrica: questo è normale.

Prima di cucinare gli alimenti è dunque raccomandato di riscaldare a vuoto il forno per rimuovere ogni odore.

RIMONTAGGIO DELLE GUIDE DI SCORRIMENTO [d]

Agganciare i ganci superiori alle guide dei ripiani (1), quindi premere la parte inferiore delle guide di scorrimento contro le guide dei ripiani, fino a far scattare i ganci inferiori (2).

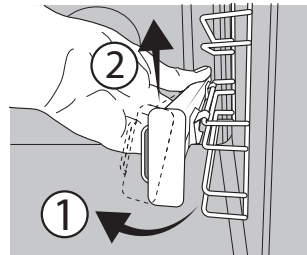

[c]

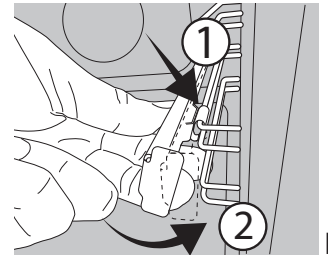

[d]

RIMUOVERE E RIMONTARE LE GRIGLIE LATERALI

1. Per rimuovere le griglie laterali, impugnare la parte esterna della griglia e tirarla verso di sé per estrarre il supporto e i due perni interni dai rispettivi alloggiamenti.
2. Per riapplicare le griglie laterali, posizzarle vicino alla parete interna del forno e inserire dapprima i due perni nei rispettivi alloggiamenti. Posizionare quindi la parte esterna vicino alla sua sede, inserire il supporto e spingere con decisione verso la parete del forno per fissare saldamente la griglia.

Rimuovere protezioni di cartone o pellicole trasparenti e togliere gli accessori dal forno.

Riscaldare il forno a 250 °C per circa un'ora. Durante questa procedura il forno deve essere vuoto.

Note: si consiglia di arieggiare il locale dopo il primo utilizzo dell'apparecchio.

FUNZIONI



OFF

Per spegnere il forno.



LAMPADA

Per accendere la luce nel forno



STATICO

Per cuocere qualsiasi tipo di pietanza su un solo ripiano.



DIAMOND CLEAN

L'azione del vapore rilasciato durante questo speciale ciclo di pulizia a bassa temperatura permette di rimuovere facilmente sporco e residui di cibo.

Versare 100-120 ml di acqua potabile sul fondo del forno, quindi ruotare la manopola di selezione e la manopola del termostato sull'icona . Si consiglia di utilizzare la funzione per 35 minuti.

Attivare la funzione a forno freddo e lasciarlo raffreddare per 15 minuti al termine del ciclo. la posizione dell'icona non corrisponde alla temperatura raggiunta durante il ciclo di pulizia.



VENTILATO

Per cuocere carne e torte salate su un unico ripiano. Questa funzione può essere utilizzata anche per cuocere su due ripiani. Invertire la posizione delle pietanze per una cottura più uniforme.



GRILL

Per grigliare bistecche, spiedini e salsicce, cucinare verdure gratinate o tostare il pane.

Quando si griglia la carne, si consiglia di utilizzare una leccarda per raccogliere i succhi di cottura: posizionarla un livello sotto la griglia e aggiungere 200 ml di acqua potabile.



TURBO GRILL

Per arrostitire grandi tagli di carne (cosce, roast beef, pollo). Si consiglia di utilizzare una leccarda per raccogliere i succhi di cottura: posizionarla un livello sotto la griglia e aggiungere 200 ml di acqua potabile.



SCONGELAMENTO

Per velocizzare lo scongelamento degli alimenti. Per attivare la funzione di scongelamento, ruotare la manopola di selezione sull'icona , quindi ruotare la manopola del termostato in senso orario su qualsiasi temperatura. Questa funzione non riscalda, quindi può essere utilizzata qualsiasi temperatura. Quando lo scongelamento è stato completato, ruotare i due comandi in posizione 0.



BOTTOM HEATING

Usare questa funzione per dorare le pietanze alla base. Si consiglia di posizionare la pietanza sul 1°/2° ripiano. Questa funzione può anche essere utilizzata per la cottura a fuoco lento di verdure o stufati; utilizzare in questo caso il 3° livello. Non è necessario preriscaldare il forno.



FORCED AIR

Per cuocere contemporaneamente su più ripiani (massimo tre) alimenti diversi che richiedono la medesima temperatura di cottura. Questa funzione permette di eseguire la cottura senza trasmissione di odori da un alimento all'altro.



PIZZA

Per cuocere diversi tipi e formati di pizza e focaccia. Si consiglia di invertire la posizione delle teglie a metà cottura.

USO QUOTIDIANO

1. SELEZIONARE UNA FUNZIONE

Per selezionare una funzione, ruotare la *manopola di selezione* in corrispondenza del simbolo della funzione desiderata.

2. AVVIARE UNA FUNZIONE

MANUALE

Ruotare la manopola selezione funzioni sulla funzione desiderata. La luce del forno si accende. Ruotare la manopola del termostato in senso orario fino alla temperatura desiderata. A fine cottura, per spegnere il forno, ruotare la manopola di selezione e la manopola del termostato su 0.

DIAMOND CLEAN

Per attivare la funzione di pulizia "Diamond Clean", versare 100 - 120 ml di acqua potabile sul fondo del forno, quindi ruotare tutte e 3 le manopole (manopola di selezione, manopola del timer e manopola del termostato) sull'icona . La funzione si attiverà automaticamente e la sua durata sarà di 35

minuti.

3. PRERISCALDAMENTO

Quando si attiva questa funzione, la spia del termostato si accende per segnalare l'inizio della fase di preriscaldamento. Al termine di questa fase, il LED del termostato si spegne ad indicare che il forno ha raggiunto la temperatura impostata: a questo punto, posizionare gli alimenti all'interno e procedere con la cottura.

Note: inserire gli alimenti nel forno prima della fine del preriscaldamento può compromettere i risultati di cottura.

4. IMPOSTAZIONE DEL TIMER

La manopola del timer può essere utilizzata per impostare un tempo di cottura compreso tra 1 e 60 minuti. Per impostare il tempo di cottura, dopo aver selezionato la funzione di cottura desiderata, ruotare la manopola di 360° in senso orario e poi ruotarla nuovamente in senso opposto fino a raggiungere la durata di cottura desiderata.

. NOTE

- Non coprire l'interno del forno con pellicola di alluminio.
- Non trascinare pentole o tegami sul fondo del forno, perché così facendo si potrebbe rovinare lo smalto.
- Non appoggiare pesi elevati sulla porta e non aggrapparsi ad essa.











. NOTE SULL'EFFICIENZA ENERGETICA

- Sfruttare il calore residuo: spegnere il forno 5/10 minuti prima della fine della cottura per utilizzare il calore residuo.
- Tenere la porta chiusa: se possibile, evitare di aprire la porta del forno durante la cottura, per evitare che il calore fuoriesca.
- Cucinare porzioni più grandi: utilizzare il forno soprattutto per piatti più grandi (ad esempio, carne di oltre 1 kg) o per porzioni più abbondanti, per sfruttare al meglio l'energia utilizzata.
- Pulire regolarmente la guarnizione della porta: una tenuta pulita impedisce la dispersione del calore e garantisce una cottura efficiente.
- Preriscaldare solo quando è necessario: preriscaldare il forno solo se consigliato nella ricetta o nella tabella di cottura.
- Scegliere teglie scure: le teglie scure assorbono meglio il calore, migliorando l'efficienza della cottura.
- Pianificare la cottura: preparare più piatti in sequenza per utilizzare il calore residuo ed evitare un ulteriore preriscaldamento.
- Rimuovere gli accessori non utilizzati: eliminare le teglie o le griglie non necessarie per migliorare l'efficienza della circolazione del calore e ridurre la capacità termica del prodotto.

TABELLA DI COTTURA

RICETTA	FUNZIONE	PRERISC.	TEMPERATURA (°C)	DURATA (Min)	LIVELLO E ACCESSORI
Torte lievitate		Sì	150 - 170	30 - 90	2
		Sì	160 - 180	30 - 90	4 1
Torta farcita (cheesecake, strudel, torta di frutta)		Sì	160 - 200	35 - 90	2
		Sì	160 - 200	40 - 90	4 2
Biscotti/Tortine		Sì	160 - 180	20 - 45	3
		Sì	150 - 170	20 - 45	4 2
		Sì	150 - 170	20 - 45	5 3 1
Bigné		Sì	180 - 210	30 - 40	3
		Sì	180 - 200	35 - 45	4 2
Meringhe		Sì	90	150 - 200	3
		Sì	90	140 - 200	4 2
		Sì	90	140 - 200	5 3 1
Pizza / foccacia		Sì	190 - 250	15 - 50	1/2
		Sì	190 - 250	20 - 50	4 2
Panini (80g)		Sì	180 - 200	30 - 45	2
Pane in cassetta (500g)		Sì	180	50 - 70	1/2
Pane		Sì	180 - 200	30 - 80	4 2
Pizza surgelata		Sì	250	10 - 20	3
		Sì	230 - 250	10 - 25	4 2
Torte salate (torta di verdure, quiche)		Sì	180 - 200	30 - 45	2
		Sì	180 - 200	35 - 50	4 2
		Sì	180 - 200	35 - 50	5 3 1
Vol-au-vent / Salatini di pasta sfoglia		-	190 - 200	20 - 30	3
		-	180 - 190	20 - 40	4 2
		-	180 - 190	20 - 40	5 3 1
Lasagne / Pasta al forno / Cannelloni / Sformati		Sì	190 - 200	45 - 65	2
Agnello / Vitello / Manzo / Maiale 1 kg		Sì	190 - 200	80 - 110	3
Maiale arrosto con cotenna 2 kg		Sì	180 - 190	110 - 150	2
Pollo / Coniglio / Anatra 1 kg		Sì	200 - 230	50 - 100	2
Tacchino / Oca 3 kg		-	190 - 200	100 - 160	2
Pesce al forno / al cartoccio (filetti, intero)		Sì	170 - 190	30 - 50	2
Verdure ripiene (zucchine, melanzane)		Sì	180 - 200	50 - 70	2
Pane tostato		-	250	2 - 6	5











FUNCTIONS					
	Statico	Grill	Turbo Grill	Pizza	Termoventilato
ACCESSORI					
	Griglia	Teglia o tortiera su griglia	Teglia / Leccarda o teglia su griglia	Leccarda / Teglia	Leccarda / teglia con 200 ml d'acqua

RICETTA	FUNZIONE	PRERISC.	TEMPERATURA (°C)	DURATA (Min)	LIVELLO E ACCESSORI
Filetti / tranci di pesce		-	230 - 250	20 - 30*	4 3
Salsicce / Spiedini / Costine / Hamburger		-	250	15 - 30*	5 4
Pollo arrosto 1-1,3 kg		Sì	200 - 220	55 - 70**	2 1
Roast beef al sangue 1 kg		Sì	200 - 210	35 - 50**	3
Cosciotto d'agnello / Stinchi		Sì	200 - 210	60 - 90**	3
Patate arrosto		Sì	200 - 210	35 - 55**	3
Verdure gratinate		-	200 - 210	25 - 55	3
Carne & Patate		Sì	190 - 200	45 - 100***	4 1
Pesce & Verdure		Sì	180	30 - 50***	4 1
Lasagne e carne		Sì	200	50 - 100***	4 1
Pasto completo: Crostata (livello 5) / lasagne (livello 3) / carne (livello 1)		Sì	180 - 190	40 - 120***	5 3 1

* Ruotare il cibo a metà cottura

** Girare gli alimenti a due terzi di cottura se necessario.

*** Tempo di cottura approssimativo: i piatti possono essere estratti dal forno in momenti diversi, a seconda delle preferenze personali.

FUNCTIONS					
	Statico	Grill	Turbo Grill	Pizza	Turboventilato
ACCESSORI					
	Griglia	Teglia o tortiera su griglia	Teglia / Leccarda o teglia su griglia	Leccarda / Teglia	Leccarda / teglia con 200 ml d'acqua

PULIZIA E MANUTENZIONE

Assicurarsi che il forno si sia raffreddato prima di effettuare qualsiasi intervento di manutenzione o pulizia.

Non utilizzare pulitori a vapore.

Non utilizzare lana metallica, pagliette abrasive o detersivi abrasivi/corrosivi, perché potrebbero danneggiare le superfici dell'apparecchio.

Indossare guanti protettivi.

Il forno deve essere scollegato dalla rete elettrica prima di effettuare qualsiasi tipo di manutenzione.

SUPERFICI ESTERNE

Pulire le superfici con un panno in microfibra umido. Se molto sporche, aggiungere qualche goccia di detersivo con pH neutro. Asciugare con un panno.

Non utilizzare detersivi corrosivi o abrasivi. Se inavvertitamente uno di questi prodotti dovesse venire a contatto con le superfici, pulire subito con un panno in microfibra umido.

SUPERFICI INTERNE

- Dopo ogni uso, lasciare raffreddare il forno e pulirlo preferibilmente quando è ancora tiepido

per rimuovere incrostazioni e macchie dovute a residui di cibo. per asciugare la condensa dovuta alla cottura di alimenti ad alto contenuto di acqua, usare a forno freddo un panno o una spugna.

- Per facilitare la pulizia dei vetri è possibile rimuovere e smontare la porta.
- Pulire i vetri della porta con detersivi liquidi specifici.

ACCESSORI

Mettere a bagno gli accessori con detersivo per piatti dopo l'uso, maneggiandoli con guanti da forno, se ancora caldi. I residui di cibo possono essere rimossi con una spazzola per piatti o con una spugna.

RIMOZIONE E MONTAGGIO DELLA PORTA

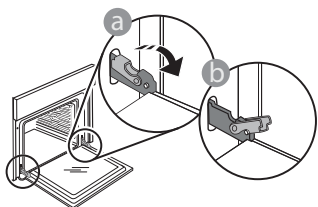

1. Per rimuovere la porta, aprirla completamente e abbassare i fermi fino alla posizione di sblocco.

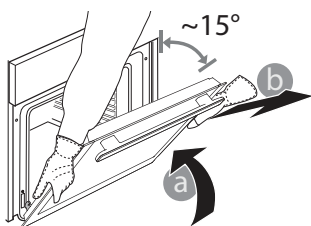

2. Chiudere la porta fino a quando è possibile. Prendere saldamente la porta con entrambe le mani, evitando di tenerla per la maniglia. È sufficiente rimuovere la porta

continuando a chiuderla e tirandola contemporaneamente verso l'alto, finché non si sgancia dalla propria sede. Togliere la porta e appoggiarla su un piano morbido.

3. Per rimontare la porta, avvicinarla al forno allineando i ganci delle cerniere alle proprie sedi e ancorare la parte superiore agli alloggiamenti.

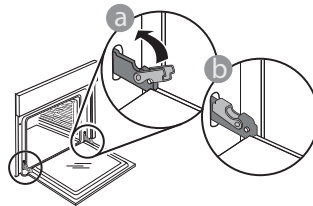

4. Abbassare la porta e poi aprirla completamente. Abbassare i fermi nella posizione originale: fare attenzione che siano completamente abbassati.

Applicare una leggera pressione per verificare che i fermi siano nella posizione corretta.

5. Provare a chiudere la porta, verificando che sia allineata al pannello di controllo. Nel caso non lo fosse, ripetere i passi sopra descritti: La porta potrebbe danneggiarsi se non funziona correttamente.

ABBASSAMENTO DELLA RESISTENZA SUPERIORE

1. estrarre la resistenza dalla sede e abbassarla.

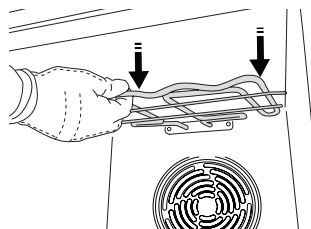
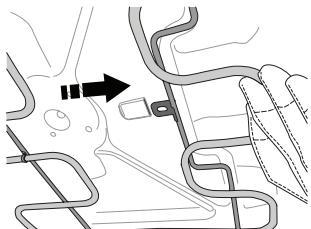

2. Per reinserire la resistenza in posizione, sollevarla, tirarla leggermente verso di sé e controllare che il supporto sia posizionato correttamente.

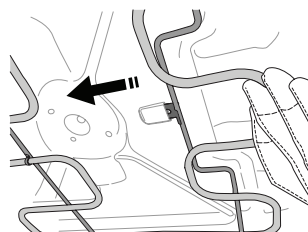

PULIZIA DEI VETRI DELLA PORTA

1. Dopo aver smontato la porta e averla appoggiata su un ripiano morbido con la maniglia verso il basso, premere contemporaneamente le due clip di fissaggio ed estrarre il profilo superiore della porta tirandolo verso di sé.

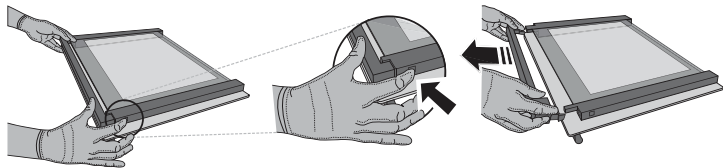

2. Sollevare e prendere saldamente il vetro interno con due mani, rimuoverlo e appoggiarlo su un piano morbido prima di eseguire la pulizia.

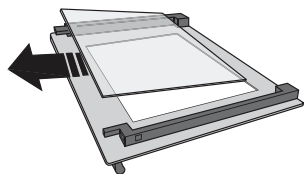

3. Prima di rimontare il vetro interno è necessario riapplicare il vetro intermedio (contrassegnato con "1R"): Per posizionare correttamente i vetri, verificare che la marcatura "R" sia visibile nell'angolo sinistro. Inserire dapprima il lato lungo del vetro contrassegnato con "R" nelle sedi di sostegno, quindi abbassarlo in posizione. Ripetere la procedura per entrambi i vetri.

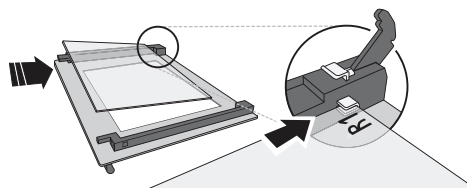

4. Rimontare il profilo superiore: Un clic indicherà il posizionamento corretto. Verificare che la tenuta sia salda prima di rimontare la porta.

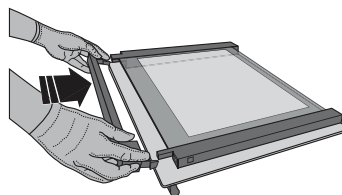

SOSTITUZIONE DELLA LAMPADINA

1. Scollegare il forno dalla rete elettrica.
2. Svitare il coperchio dalla luce, sostituire la lampadina e riavvitare il coperchio sulla luce.
3. Ricollegare il forno alla rete elettrica.

Nota: Usare lampadine alogene da 25 W/230 V tipo G9, T300°C. La lampada utilizzata nel prodotto è specifica per elettrodomestici e non è adatta per l'illuminazione di ambienti domestici (Regolamento (CE) 244/2009).

Le lampade sono disponibili presso il Servizio Assistenza Tecnica. - Non maneggiare le lampadine a mani nude, perché le impronte digitali potrebbero danneggiarle. Non far funzionare il forno senza prima aver riposizionato il coperchio.

RISOLUZIONE DEI PROBLEMI

PROBLEMA	POSSIBILE CAUSA	SOLUZIONE
Il forno non funziona.	Interruzione di corrente elettrica. Disconnessione dalla rete principale.	Verificare che ci sia tensione in rete e che il forno sia collegato all'alimentazione elettrica. Spegner e riaccendere il forno e verificare se l'inconveniente persiste.

Per le linee guida, la documentazione standard e altre informazioni sui prodotti:

- Utilizzare il codice QR sul proprio apparecchio
- Visitare il sito web docs.hotpoint.eu
- Oppure, **contattare il Servizio Assistenza Tecnica** (al numero di telefono riportato sul libretto di garanzia). Prima di contattare il Servizio Assistenza Clienti, prepararsi a fornire i codici riportati sulla targhetta matricola del prodotto.

