

DFC 2B+19 AC

12NC: 869991589590

GTIN (EAN) code: 8050147589595

 **INDESIT**

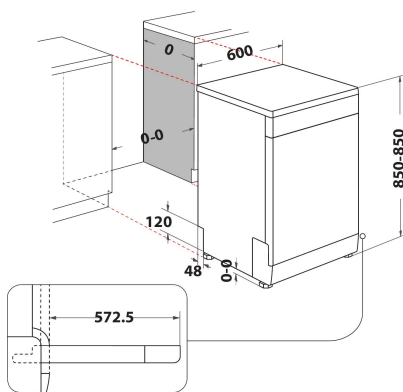

MAIN FEATURES

Construction type	Samostojeći
Installation type	Samostojeći
Type of control	Electronic
Type of control settings	-
Removable work top	Yes
Main colour of product	White
Electrical connection rating (W)	1900
Current (A)	10
Voltage (V)	220-230
Frequency (Hz)	50
Length of electrical supply cord (cm)	130
Plug type	Schuko
Length inlet hose (cm)	155
Length outlet hose (cm)	150
Adjustable feet	Yes - all
Height of the product	850
Width of the product	600
Depth of the product	590
Minimum niche height	0
Maximum niche height	0
Minimum niche width	0
Maximum niche width	0
Niche depth	590
Net weight (kg)	47
Gross weight (kg)	49

TECHNICAL FEATURES

Automatic programmes	Ne
Maximum temperature for water intake (°C)	0
Start delay options	One time fixed
Start delay time max. (h)	8
Progress indicator	-
Digital countdown indicator	Yes
Salt light indicator	Yes
Rinse aid light indicator	Yes
Safety device	Yes
Adjustable upper basket	Yes
Largest loadable dish upper basket (cm)	0
Largest loadable dish lower basket (cm)	0
Maksimalan broj mjesta za jelo (EU 2017/1369)	13
Column installation	Ne

ENERGY LABEL

Energy Efficiency Class (Regulation (EU) 2017/1369)	F
Energy Consumption for 100 cycles Eco Programme (EU 2017/1369)	104
Potrošnja energije u stanju pripravnosti (Psm) (EU 2017/1369)	0,50
Power consumption in off-mode (Po) (EU 2017/1369)	0,50
Potrošnja vode eko programa u litrama po ciklusu (EU 2017/1369)	12,0
Airborne acoustical noise emissions (EU 2017/1369)	49
Airborne acoustical noise emission class (EU 2017/1369)	C