

AKR 759 IX

12NC: 857875901000

GTIN (EAN) code: 8003437218255

Whirlpool

SENSING THE DIFFERENCE

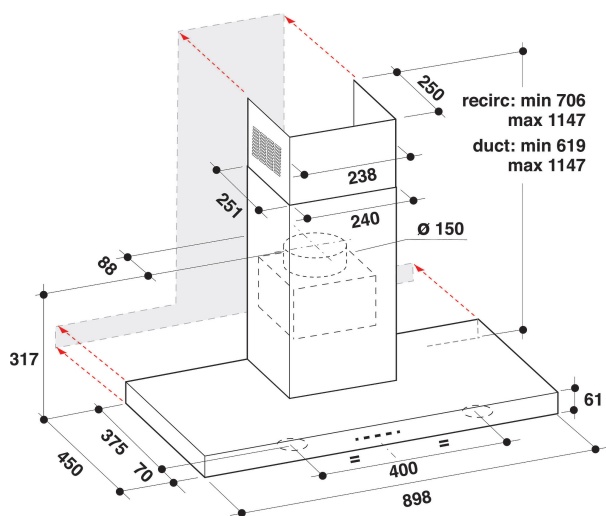

MAIN FEATURES

Product group	Odsávače
Colour body	Nerez
Material body	Stainless steel
Colour chimney	Nerez
Material chimney	Stainless steel
Typology	Manual
Installation type	Wall-mounted
Type of control	Electronic
Type of control settings	-
Decor panel options	N/A
Motor location	Integrated motor in hood chimney
Operating Mode	Convertible
Electrical connection rating (W)	280
Current (A)	1,2
Voltage (V)	220-240
Frequency (Hz)	50
Length of Electrical Supply Cord (cm)	150
Plug type	Schuko
Chimney height (mm)	580
Height of product, without chimney (mm)	60
Height of the product	619
Width of the product	898
Depth of the product	450
Minimum niche height	0
Minimum niche width	0
Niche depth	0
Net weight (kg)	19.3

TECHNICAL FEATURES

Type of manual control devices	Touch control
Type of automatic control devices	-
Number of motors	1
Total power of the motors (W)	250
Number of speed settings: boost option availability	4
Boost presence	Áno
Maximum output air extraction (m ³ /h)	704
Boost position air extraction (m ³ /h)	704
Maximum output recirculating air (m ³ /h)	356
Boost position output recirculating (m ³ /h)	356
Light Control Type	On/Off
Number of lights	2
Type of lamps used	Halogen
Total power of the lamps (W)	20
Diameter of air outlet (mm)	150
No-return airflow flap	Áno
Grease filter material	Washable aluminium
Odour filter	Nie

ENERGETICKÝ ŠTÍTK

Sound power at min. speed (2010/30/EU)	52
Sound power at max. speed (2010/30/EU)	69
Noise level with boost position (dB(A) re 1 pW)	0