

FFT M22 9X2B UK

12NC: 859991636220

GTIN (EAN) code: 8003437625497

Whirlpool

SENSING THE DIFFERENCE

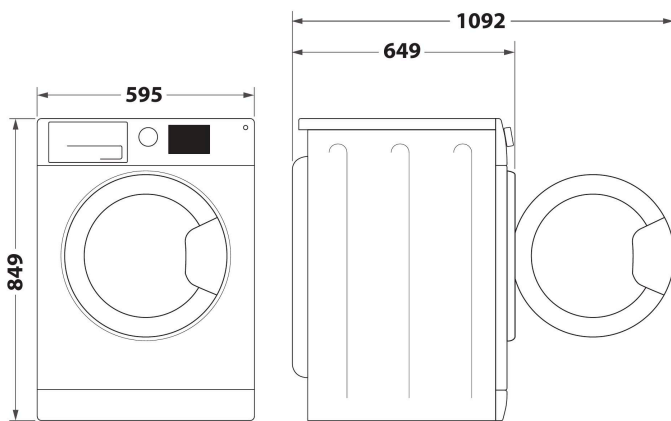

- Energy class A++
- Drying capacity: 9,0 kg
- White finishing
- 6TH Sense Technology
- Heat pump technology
- FreshCare+
- Start delay 1-24h
- Drying time
- Delicates
- Adjustable dryness levels
- Rapid program
- Eco Cotton
- Wool
- Mixed Fabrics Program
- Special big items
- Jeans
- Sport

Whirlpool heat pump tumble dryer: freestanding, 9,0kg - FFT M22 9X2B UK

This Whirlpool freestanding Tumble Dryer features: outstanding 9,0kg drum capacity, so you will never run out of space. Exclusive 6th SENSE technology that constantly monitors the moisture in the drum, protecting your clothes and providing ideal drying results. Heat pump technology that effectively re-heats the air in the appliance, significantly reducing energy consumption.



Quiet

This Whirlpool Dryer is designed to produce limited noise output.



6th Sense

6th Sense automatically detects the amount of laundry and sets the right drying cycle time, guaranteeing the desired dryness level, with time and energy optimization.



FreshCare+

Keep your garments fresh up to 6 hours after the cycle is over*. Innovative FreshCare+ system takes care of your garments inside the dryer thanks to intelligent delicate temperature control and delicate tumbling action that keep garments fresh and prevent bad odours. FreshCare+ treatment leaves truly fresher clothes and peace of mind - even hours after the end of the cycle. *FreshCare+ treatment inhibits the proliferation of the main bad odour sources (inside the dryer) up to 6 hours after the drying ends. Not compatible with programmes designed for delicate garments and with extra and cupboard drying levels.



9kg capacity

All the space you need. With an outstanding 9kg drum capacity, this Whirlpool Dryer provides all the space you need for your laundry.



Energy Class A++

Highly energy efficient With its A++ energy rating, this Whirlpool Dryer will allow you to enjoy both ideal results and very low energy consumption.



User interface friendly

Effortless control. This Whirlpool Dryer includes an intuitive user interface, for increased ease-of-use.



Direct Drain

Forget about emptying the water tank. Save time and effort by connecting your dryer's drain hose to drain pipe.



Heatpump

Outstanding energy efficiency. By using a heat pump rather than a conventional heating element, you can achieve the same drying results at lower temperatures: 40°C on average, rather than 60°C.

FFT M22 9X2B UK

12NC: 859991636220

GTIN (EAN) code: 8003437625497

Whirlpool

SENSING THE DIFFERENCE

MAIN FEATURES

| | |
|---------------------------------------|-----------------|
| Product group | Dryer |
| Commercial code | FFT M22 9X2B UK |
| GTIN (EAN) code | 8003437625497 |
| Construction type | Free-standing |
| Installation type | Free-standing |
| Removable work top | No |
| Loading type | Front loader |
| Main colour of product | White |
| Electrical connection rating (W) | 850 |
| Current (A) | 10 |
| Voltage (V) | 220-240 |
| Frequency (Hz) | 50 |
| Length of Electrical Supply Cord (cm) | 150 |
| Plug type | UK |
| Height of the product | 849 |
| Width of the product | 595 |
| Depth of the product | 649 |
| Depth with open door 90 degree (mm) | 1092 |
| Net weight (kg) | 44 |

TECHNICAL FEATURES

| | |
|-------------------------------|------------|
| Automatic programmes | Yes |
| Moisture monitoring system | Yes |
| Adjustable drying temperature | No |
| Progress indicator | Yes |
| Digital countdown indicator | Yes |
| Start delay options | Continuous |
| Start delay time max. (h) | 24 |
| Blocked filter indicator | Yes |
| Full tank indicator | Yes |
| Quick dry | No |
| Anti-crease function | Yes |
| Drum volume (l) | 120 |

PERFORMANCES

| | |
|---|-----------|
| Energy efficiency class - NEW (2010/30/EU) | A++ |
| Condensation efficiency class - NEW (2010/30/EU) | B |
| Energy consumption electric dryer, full load - NEW (2010/30/EU) | 2,13 |
| Weighted condensation efficiency | 81 |
| Weighted annual energy consumption, electric dryer - NEW (2010/30/EU) | 258,0 |
| Capacity cotton (kg) - NEW (2010/30/EU) | 9,0 |
| Dryer type | Condenser |
| Noise level (dB(A) re 1 pW) | 64 |
| Standard cotton programme time at full load | 211 |
| Standard cotton programme time at partial load | 131 |
| Weighted programme time | 165 |
| Power consumption in left-on mode - NEW (2010/30/EU) | 2,00 |
| Duration of the left-on mode - NEW (2010/30/EU) | 15 |
| Power consumption in off-mode - NEW (2010/30/EU) | 0,42 |

ENERG Y IJA
енергия · ενεργεια
IE IA

WHIRLPOOL
FFT M22 9X2B UK

A+++
A++
A+
A
B
C
D

A++

258,0
kWh/annum

ENERGIA · ЕНЕРГИЯ · ENERGIEIA
ENERGIJA · ENERGY · ENERGIE
ENERGI

211 min/cycle*
9,0 kg
64 dB

ABCDEF G

* λικετα · циклу · portion · zykus
tipolozovje · ciclo · tsiklul
ohjelma · ciklus · ciklas · cikls
ciklu · cyclus · cykl · ciclu
program · taskimgilng

392/2012