

# WHBS 92F LT K

12NC: 859991542360

GTIN (EAN) code: 8003437231049

Whirlpool

SENSING THE DIFFERENCE

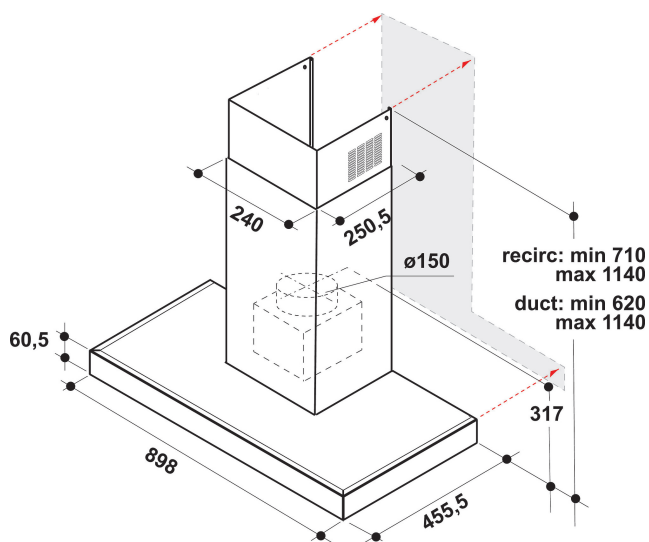

- 6TH Sense technology
- Maximum noise level 62 dBA
- Noise Level (min. - max.): 38-62 dBA
- Air Flow (min. - max.): 135, 464, booster 750 m<sup>3</sup>/h
- Maximum extraction rate: 464 (m<sup>3</sup>/h)
- Energy class A
- Extraction / Recirculation Rate  
%Z\_REQ\_MAX\_OUT\_EXTRACTION% / 356 m<sup>3</sup>/h
- Continuous speed setting
- Odour Filter
- ZenMode
- CookSense
- 1 Strip LED, 7 W lamp
- 1 x 270 W motor
- Electronic Touch control
- 3 Washable aluminium filters
- Grease Filtering Efficiency Class: C

## Whirlpool wall mounted cooker hood - WHBS 92F LT K

This Whirlpool wall mounted Cooker Hood features: dishwasher-safe, washable aluminium grease filters. An outstanding cooker extractor fan, ensuring a fresh, grease-free cooking environment. Between 60cm and 90cm wide appliance. Exclusive 6th SENSE sensor technology that dynamically adjusts energy consumption, depending on what you are cooking. New design ensuring extra silent performance.

### Strip LED

Illuminates the cooktop surface at best without any waste of energy.

### CookSense

CookSense intuitively selects the right extraction rate for any style of cooking.

### ZenMode

Providing the ideal balance between performance and silence, Whirlpool's ZenMode ensures the hood is powerful enough to keep the air fresh and clean while making the kitchen a quieter, more enjoyable place for cooking and socialising.

### Booster

Odour-free cooking. This Whirlpool Hood features an extraction booster, that ensures ideal air filtration and odour and grease aspiration.

### Wall-mounted installation

Wall-mounted installation. This wall-mounted Whirlpool Hood is a breeze to install.

### Total annual energy consumption

Ideal performance, outstanding savings. Whirlpool Hoods are designed to provide exceptional results, while reducing energy costs.

### Electronic control

Effortless control. This Whirlpool Hood includes an intuitive electronic user interface, designed to provide you with the simplest, most satisfying user experience ever.

### 6th sense

Exceptional energy savings. The exclusive 6th SENSE technology allows your hood to dynamically adjust its energy consumption, based on what you are cooking.

### Carbon Filter Included

Enjoy fresh air in your kitchen, always. This Whirlpool Hood includes a carbon purifying air filter, that effectively protects your kitchen from odours and grease.

### Energy class A

Energy efficient. With its A energy rating, this Whirlpool appliance will allow you to enjoy both ideal performance and excellent energy consumption.

# WHBS 92F LT K

12NC: 859991542360

GTIN (EAN) code: 8003437231049

**Whirlpool**

SENSING THE DIFFERENCE

## MAIN FEATURES

Product group	Hood
Colour body	Inox
Material body	Aluminium
Colour chimney	Inox
Material chimney	Aluminium
Typology	Wall-mounted
Installation type	Wall-mounted
Type of control	Electronic
Type of control settings	-
Decor panel options	Not possible
Motor location	Integrated motor in hood body
Operating Mode	Convertible
Electrical connection rating (W)	277
Current (A)	1,12
Voltage (V)	220-240
Frequency (Hz)	50
Length of Electrical Supply Cord (cm)	150
Plug type	Schuko
Chimney height (mm)	580
Height of product, without chimney (mm)	300
Height of the product	1140
Width of the product	898
Depth of the product	455
Minimum niche height	0
Minimum niche width	0
Niche depth	0
Net weight (kg)	15.5

## TECHNICAL FEATURES

Type of manual control devices	Touch control
Type of automatic control devices	-
Number of motors	1
Total power of the motors (W)	270
Number of speed settings: boost option availability	Continuous
Boost presence	Yes
Maximum output air extraction (m <sup>3</sup> /h)	464
Boost position air extraction (m <sup>3</sup> /h)	750
Maximum output recirculating air (m <sup>3</sup> /h)	356
Boost position output recirculating (m <sup>3</sup> /h)	386
Light Control Type	On/Off
Number of lights	1
Type of lamps used	Strip LED
Total power of the lamps (W)	7
Diameter of air outlet (mm)	150
No-return airflow flap	No
Grease filter material	Washable aluminium
Odour filter	Yes

## PERFORMANCES

Sound power at min. speed (2010/30/EU)	38
Sound power at max. speed (2010/30/EU)	62
Noise level with boost position (dB(A) re 1 pW)	58

**ENERG** Y IJA  
енергия · ενεργεια IE IA

**WHIRLPOOL**  
WHBS 92F LT K

A+++  
A++  
A+  
**A**  
B  
C  
D

47  
kWh/annum

ABCDEF G ABCDEF G ABCDEF G **62** dB

65/2014