

DAILY REFERENCE GUIDE



THANK YOU FOR PURCHASING AN HOTPOINT-ARISTON PRODUCT

To receive more comprehensive help and support, please register your product at www.hotpoint.eu/register



You can download the Safety Instructions and the Use and Care Guide by visiting our website docs.hotpoint.eu and following the instructions on the back of this booklet.



Before using the appliance carefully read the Health and Safety guide.

PRODUCT DESCRIPTION

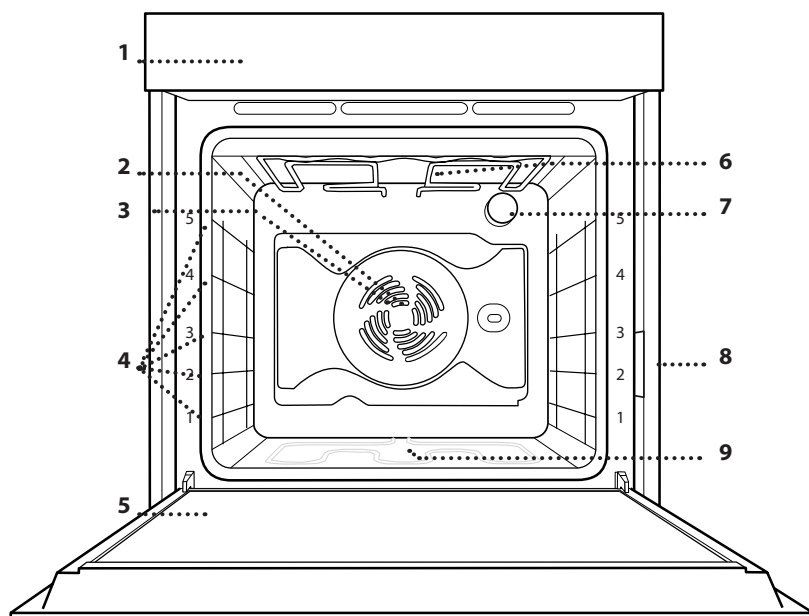

1. Control panel
2. Fan
3. Circular heating element (not visible)
4. Shelf guides (the level is indicated on the front of the oven)
5. Door
6. Upper heating element/grill
7. Lamp
8. Identification plate (do not remove)
9. Lower heating element (not visible)

CONTROL PANEL

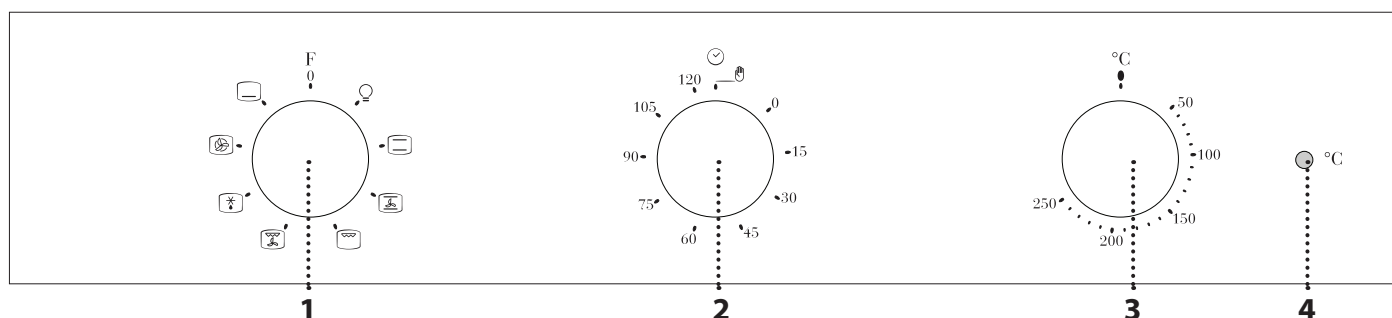

1. SELECTION KNOB

For switching the oven on by selecting a function. Turn to the position (0) to switch the oven off.

2. TIMER KNOB

For setting the desired cooking time.

3. THERMOSTAT KNOB

Turn to select the desired temperature.

4. LED THERMOSTAT / PREHEATING

Switches on during the heating process. Switches off once the desired temperature is reached.

ACCESSORIES

WIRE SHELF

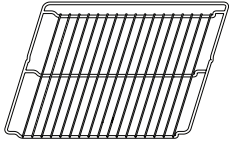

Use to cook food or as a support for pans, cake tins and other ovenproof items of cookware

DRIP TRAY*

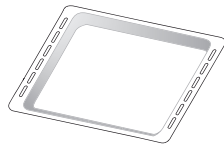

Use as an oven tray for cooking meat, fish, vegetables, focaccia, etc. or position underneath the wire shelf to collect cooking juices.

BAKING TRAY*

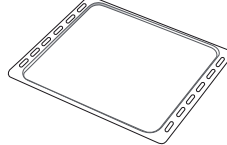

Use for cooking all bread and pastry products, but also for roasts, fish en papillote, etc.

SLIDING RUNNERS*

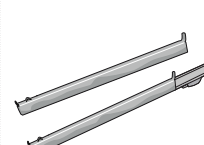

To facilitate inserting or removing accessories.

* Available only on certain models.

The number and the type of accessories may vary depending on which model is purchased. Other accessories can be purchased separately from the After-sales Service.

INSERTING THE WIRE SHELF AND OTHER ACCESSORIES

Insert the wire shelf horizontally by sliding it across the shelf guides, making sure that the side with the raised edge is facing upwards.

Other accessories, such as the drip tray and the baking tray, are inserted horizontally in the same way as the wire shelf.

REMOVING AND REFITTING THE SHELF GUIDES

- To remove the shelf guides, lift the guides up and then gently pull the lower part out of its seating: the shelf guides can now be removed.
- To refit the shelf guides, first fit them back into their upper seating. Keeping them held up, slide them into the cooking compartment, then lower them into position in the lower seating.

FITTING THE SLIDING RUNNERS (IF PRESENT)

Remove the shelf guides from the oven and remove the protective plastic from the sliding runners. Fasten the upper clip of the runner to the shelf guide and slide it along as far as it will go. Lower the other clip into position. To secure the guide, press the lower portion of the clip firmly against the shelf guide. Make sure that the runners can move freely. Repeat these steps on the other shelf guide on the same level.

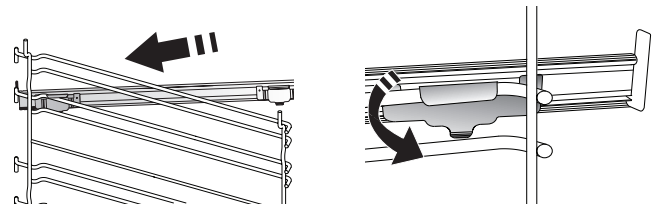

Please note: The sliding runners can be fitted on any level.

USING THE APPLIANCE FOR THE FIRST TIME

.HEAT THE OVEN

A new oven may release odours that have been left behind during manufacturing: this is completely normal.

Before starting to cook food, we therefore recommend heating the oven with it empty in order to remove any possible odours.

Remove any protective cardboard or transparent film from the oven and remove any accessories from inside it.











Heat the oven to 250° C for about one hour, preferably using the "Convection bake" function. The oven must be empty during this time. Follow the instructions for setting the function correctly.

Please note: It is advisable to air the room after using the appliance for the first time.

FUNCTIONS AND DAILY USE

1. SELECT A FUNCTION

To select a function, turn the *selection knob* to the symbol for the function you require.

-  OFF
For switching off the oven.
-  LIGHT
To switch the oven light on.
-  CONVENTIONAL
For cooking any kind of dish on one shelf only.
-  DIAMOND CLEAN (Only in some models)
The action of the steam released during this special low-temperature cleaning cycle allows dirt and food residues to be removed with ease. This function should be activated only when the oven is cold and after having poured 200 ml of water into the bottom of the oven. Set the timer for 30 minutes and the temperature at 90°C. Once the cycle is finished, wait about 15 minutes before opening the door.
-  CONVECTION BAKE
For cooking meat or baking cakes with liquid centre on a single shelf. This function delivers an even, golden, crisp top and base.
-  GRILL
For grilling steaks, kebabs and sausages, cooking vegetables au gratin or toasting bread. When grilling meat, we recommend using a drip tray to collect the cooking juices: position the tray on any of the levels below the wire shelf and add 500 ml of drinking water.
-  TURBO GRILL
For roasting large joints of meat (legs, roast beef, chicken). We recommend using a drip tray to collect the cooking juices: position the pan on any of the levels below the wire shelf and add 500 ml of drinking water. The roasting spit (if provided) can be used with this function.
-  DEFROSTING
For defrosting food more quickly.
-  FORCED AIR
For cooking different foods that require the same cooking temperature on several shelves (maximum three) at the same time. This function can be used to cook different foods without odours being transferred from one food to another.
-  LOWER HEATING
Useful for browning the base of the dish. This function is recommended also for slow-cooking, for

finishing the cooking of juicy dishes, and making sauce concentrates.

2. ACTIVATE A FUNCTION

To start the function you have selected, turn the *thermostat knob* to set the temperature you require.

By using the *timer knob*, it is possible to set the cooking time between 1 and 120 minutes. Turn the *timer knob* clockwise as far as it will go, then select the desired cooking time by turning the *timer knob* counter-clockwise.

When the desired cooking time has finished, the oven will switch off automatically and the *timer knob* will remain on 0.

To use the oven manually, make sure that the knob is positioned on .

Please note: if the *timer knob* is on 0, you will not be able to activate any of the functions.

To interrupt the function at any time, switch off the oven, turn the *selection knob* and the *thermostat knob* to 0 and .

DIAMOND CLEAN (If present)

To activate the "Diamond Clean" cleaning function, pour 200 ml of drinking water into the bottom of the oven, then turn the *selection knob* and the *thermostat knob* to the .





























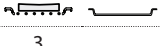











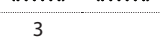































3. PREHEATING











Once the function has been activated, the LED thermostat will switch on signalling that the preheating process has begun.

At the end of this process, the LED thermostat switches off indicating that the oven has reached the set temperature: at this point, place the food inside and proceed with cooking.

Please note: placing the food in the oven before preheating has finished may have an adverse effect on the final cooking result.

COOKING TABLE











RECIPE	FUNCTION	PREHEAT	TEMPERATURE (°C)	DURATION (MIN)	SHELF AND ACCESSORIES
Leavened cakes / Sponge cakes		Yes	150 - 175	35 - 90	3 
		Yes	150 - 170	30 - 90	4 1  
Filled cakes (cheesecake, strudel, apple pie)		Yes	150 - 190	30 - 85	3 
		Yes	150 - 190	35 - 90	4 1  
Cookies / Small cakes		Yes	160 - 175	20 - 45	3 
		Yes	150 - 175	20 - 45	4 1  
Choux buns		Yes	175 - 200	30 - 40	3 
		Yes	170 - 190	35 - 45	4 1  
Meringues		Yes	100	110 - 150	3 
		Yes	100	130 - 150	4 1  
Pizza / Bread / Focaccia		Yes	190 - 250	12 - 50	3 
		Yes	190 - 250	20 - 50	4 1  
Frozen pizza		Yes	250	10 - 15	3 
		Yes	250	10 - 20	4 1  
Savoury pies (vegetable pie, quiche)		Yes	175 - 200	35 - 55	3 
		Yes	175 - 190	45 - 60	4 1  
Vols-au-vent / Puff pastry crackers		Yes	175 - 200	20 - 30	3 
		Yes	175 - 190	25 - 45	4 1  
Lasagne / Flans / Baked pasta / Cannelloni		Yes	200	45 - 65	3 
Lamb / Veal / Beef / Pork 1 kg		Yes	200	80 - 110	3 
Chicken / Rabbit / Duck 1 kg		Yes	200	50 - 100	3 
Turkey / Goose 3 kg		Yes	200	80 - 130	2 
Baked fish / en papillote (fillets, whole)		Yes	175 - 200	40 - 60	3 
Stuffed vegetables (tomatoes, courgettes, aubergines)		Yes	175 - 200	50 - 60	2 
Roast chicken 1-1.3 kg		—	200	55 - 70 *	2 1  
Toast		—	200	2 - 5	5 
Fish fillets / Steaks		—	200	20 - 30 *	4 3  
Sausages / Kebabs / Spare ribs / Hamburgers		—	200	30 - 40 *	5 4  
Roast beef rare 1 kg		—	200	35 - 45 **	3 
Leg of lamb / Shanks		—	200	60 - 90 **	3 
Roast potatoes		—	200	45 - 55 **	3 

RECIPE	FUNCTION	PREHEAT	TEMPERATURE (°C)	DURATION (MIN)	SHELF AND ACCESSORIES
Vegetable gratin		—	200	20 - 30	3 
Lasagna & Meat		Yes	200	50 - 100 ***	4 1  
Meat & Potatoes		Yes	200	45 - 100 ***	4 1  
Fish & Vegetables		Yes	175	30 - 50 ***	4 1  

* Turn food halfway through cooking.

** Turn food two thirds of the way through cooking (if necessary).

*** Estimated length of time: dishes can be removed from the oven at different times depending on personal preference.

FUNCTIONS	 Conventional	 Grill	 Turbo Grill	 Convection Bake	 Forced Air
ACCESSORIES	 Wire Shelf	 Oven tray or cake tin on wire shelf	 Drip tray / baking tray or oven tray on wire shelf	 Drip tray / Baking tray	 Drip tray with 500 ml of water

USEFUL TIPS

HOW TO READ THE COOKING TABLE

The table lists the best function, accessories and level to use to cook various different types of food. Cooking times start from the moment food is placed in the oven, excluding preheating (where required). Cooking temperatures and times are approximate and depend on the amount of food and the type of accessory used. Use the lowest recommended settings to begin with and, if the food is not cooked enough, then switch to higher settings. Use the accessories supplied and preferably darkcoloured metal cake tins and baking trays. You can also use Pyrex or stoneware pans and accessories, but bear in mind that cooking times will be slightly longer.

COOKING DIFFERENT FOODS AT THE SAME TIME

Using the "Forced Air" function, you can cook different foods which require the same cooking temperature at the same time (for example: fish and vegetables), using different shelves. Remove the food which requires a shorter cooking time and leave the food which requires a longer cooking time in the oven.

CLEANING AND MAINTENANCE

Make sure that the oven has cooled down before carrying out any maintenance or cleaning. Do not use steam cleaners.

Do not use wire wool, abrasive scourers or abrasive/corrosive cleaning agents, as these could damage the surfaces of the appliance.

Wear protective gloves. The oven must be disconnected from the mains before carrying out any kind of maintenance work.

EXTERIOR SURFACES

• Clean the surfaces with a damp microfibre cloth. If they are very dirty, add a few drops of pH-neutral detergent. Finish off with a dry cloth.

• Do not use corrosive or abrasive detergents. If any of these products inadvertently comes into contact with the surfaces of the appliance, clean immediately with a damp microfibre cloth.

INTERIOR SURFACES

• After every use, leave the oven to cool and then clean it, preferably while it is still warm, to remove any deposits or stains caused by food residues. To dry any condensation that has formed as a result of cooking foods with a high water content, let the oven to cool completely and then wipe it with a cloth or sponge.

• Activate the “Diamond Clean” function for optimum cleaning of the internal surfaces. (If present).
• Clean the glass in the door with a suitable liquid detergent.
• The oven door can be removed to facilitate cleaning.

ACCESSORIES

• Soak the accessories in a washing-up liquid solution after use, handling them with oven gloves if they are still hot. Food residues can be removed using a washing-up brush or a sponge.

CLEANING THE CATALYTIC PANELS

(ONLY IN SOME MODELS)

This oven could be equipped with special catalytic liners that facilitate cleaning of the cooking compartment thanks to their special self-cleaning coating, which is highly porous and able to absorb grease and grime. These panels are fitted to the shelf guides: When repositioning and then refitting the shelf guides, make sure that the hooks at the top are slotted into the appropriate holes in the panels.

To make best use of the catalytic panels’ self-cleaning properties, we recommend heating the oven to 200 °C for around one hour using the “Convection Bake” function. The oven must be empty during this time. Then leave the oven to cool down before removing any remaining food residues using a non-abrasive sponge.

Please note: Using corrosive or abrasive cleaning agents, stiff brushes, pan scourers or oven sprays could damage the catalytic surface and compromise its self-cleaning properties. Please contact our After-sales Service if you require replacement panels.

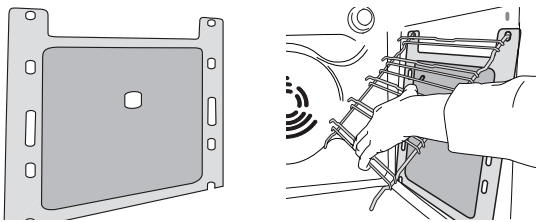

REPLACING THE LAMP

1. Disconnect the oven from the power supply.
2. Unscrew the cover from the light, replace the bulb and screw the cover back on the light.
3. Reconnect the oven to the power supply.

Please note: Only use 20-40 W/230 ~ V type G9, T300°C halogen bulbs. The bulb used in the product is specifically designed for domestic appliances and is not suitable for general room lighting within the home (EC Regulation 244/2009). Light bulbs are available from our After-sales Service.
- If using halogen bulbs, do not handle them with your bare hands as your fingerprints could cause damage. Do not use the oven until the light cover has been refitted.

LOWER THE TOP HEATING ELEMENT

(ONLY IN SOME MODELS)

1. Remove the lateral shelf guides.

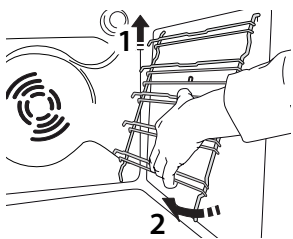

2. Pull the heating element out a little and lower it.

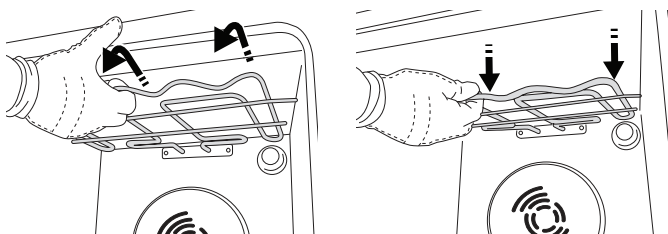

3. To reposition the heating element, lift it up, pulling it slightly towards you, making sure it comes to rest on the lateral supports.

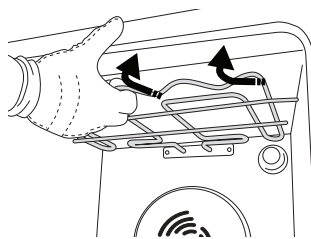

REMOVING AND REFITTING THE DOOR

1. To remove the door, open it fully and lower the catches until they are in the unlock position.

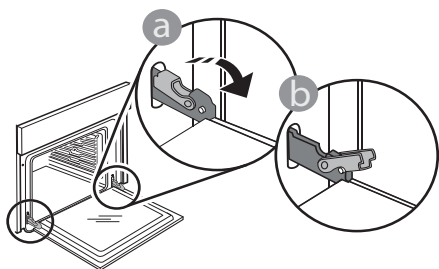

2. Close the door as much as you can.

Take a firm hold of the door with both hands - do not hold it by the handle.

Simply remove the door by continuing to close it while pulling it upwards at the same time until it is released from its seating. Put the door to one side, resting it on a soft surface.

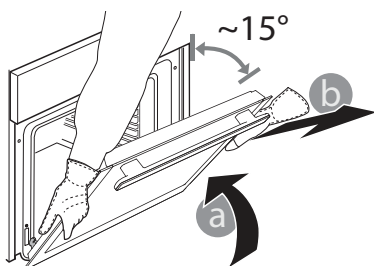

3. Refit the door by moving it towards the oven, aligning the hooks of the hinges with their seating and securing the upper part onto its seating.
4. Lower the door and then open it fully. Lower the catches into their original position: Make sure that you lower them down completely.

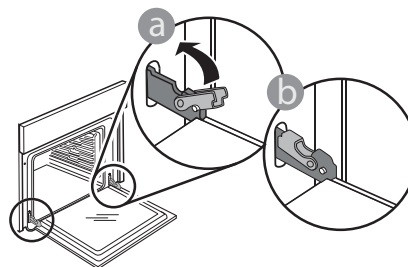

Apply gentle pressure to check that the catches are in the correct position (only in some models).

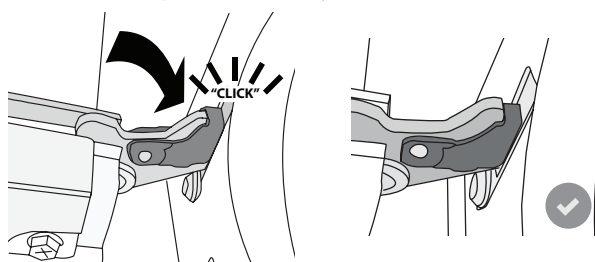

5. Try closing the door and check to make sure that it lines up with the control panel. If it does not, repeat the steps above: The door could become damaged if it does not work properly.

TROUBLESHOOTING

Problem	Possible cause	Solution
The oven is not working.	Power cut. Disconnection from the mains.	Check for the presence of mains electrical power and whether the oven is connected to the electricity supply. Turn off the oven and restart it to see if the fault persists.
Cooking will not start.	Timer knob set to 0 .	Turn the timer knob to  or select a cooking time as indicated in the Daily Use chapter.
The door will not close properly.	The safety catches are in the wrong position.	Make sure that the safety catches are in the correct position by following the instructions for removing and refitting the door in the "Cleaning and Maintenance" section.

PRODUCT FICHE

 [www](http://www.docs.hotpoint.eu) The product fiche with energy data of this appliance can be downloaded from the website **docs.hotpoint.eu**

HOW TO OBTAIN THE USE AND CARE GUIDE

>  [www](http://www.docs.hotpoint.eu) Download the Use and Care Guide from our website **docs.hotpoint.eu** (you can use this QR Code), specifying the product's commercial code.



> Alternatively, contact our Client After-sales Service.

CONTACTING OUR AFTER-SALES SERVICE

You can find our contact details in the warranty manual. When contacting our Client After-sales Service, please state the codes provided on your product's identification plate.

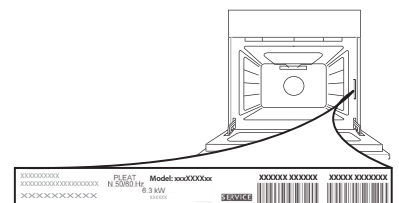

GUIDA RAPIDA



GRAZIE PER AVER ACQUISTATO UN PRODOTTO HOTPOINT - ARISTON

Per ricevere un'assistenza più completa, registrare il prodotto su www.hotpoint.eu/register



Scaricare le istruzioni per la sicurezza e le istruzioni per l'uso collegandosi al sito docs.hotpoint.eu e seguire la procedura indicata sul retro.

! Leggere attentamente le istruzioni per la sicurezza prima di utilizzare il prodotto.

DESCRIZIONE PRODOTTO

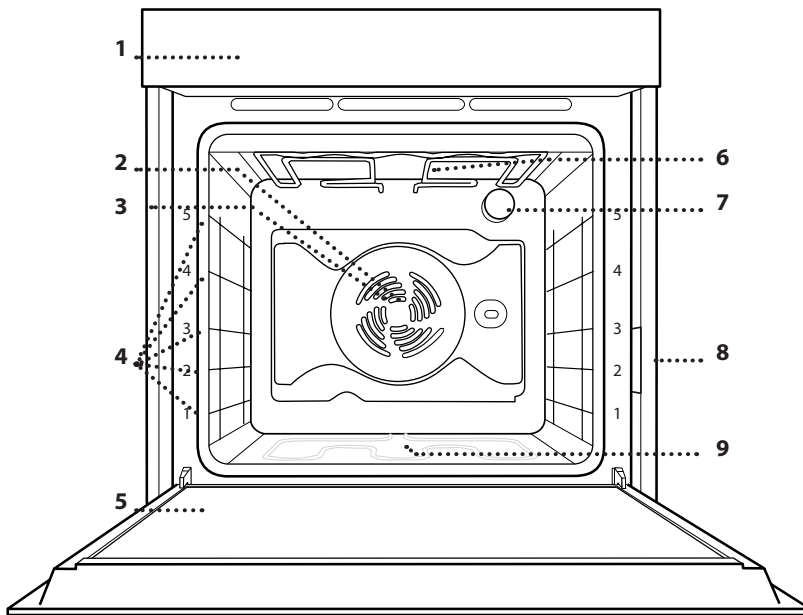

1. Pannello comandi
2. Ventola
3. Resistenza circolare (non visibile)
4. Griglie laterali (il livello è indicato sulla parte frontale del forno)
5. Porta
6. Resistenza superiore / grill
7. Lampada
8. Targhetta matricola (da non rimuovere)
9. Resistenza inferiore (non visibile)

PANNELLO COMANDI

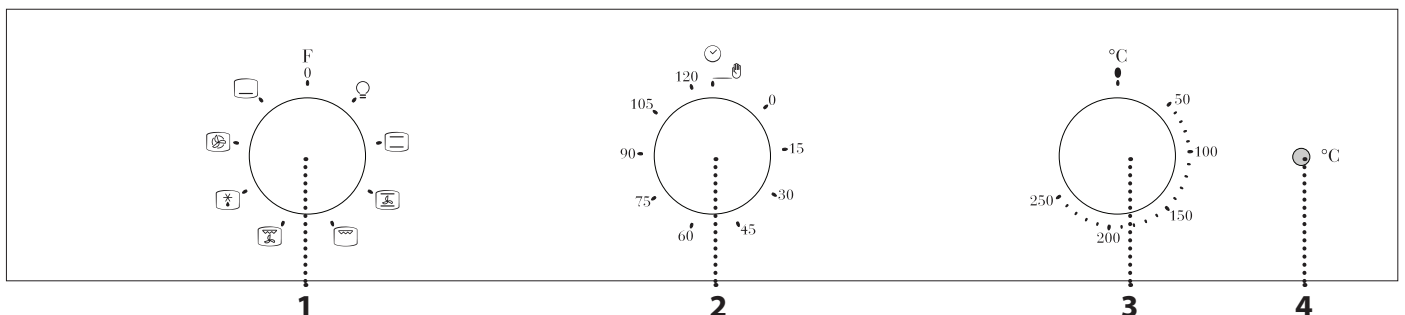

1. MANOPOLA DI SELEZIONE
Per accendere il forno selezionando una funzione. Per spegnere il forno, ruotare sulla posizione (0).

2. MANOPOLA DEL TIMER
Per impostare la durata di cottura desiderata.

3. MANOPOLA TERMOSTATO
Ruotare per selezionare la temperatura desiderata.

4. SPIA TERMOSTATO / PRERISCALDAMENTO
Si accende durante la fase di riscaldamento. Si spegne al raggiungimento della temperatura desiderata.

ACCESSORI

GRIGLIA

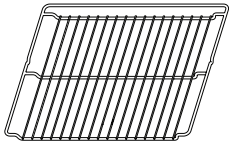

Da usare per la cottura degli alimenti o come supporto per pentole, tortiere e altri utensili da cucina

LECCARDA*

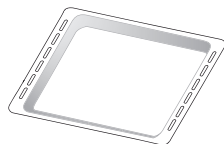

Da posizionare sotto la griglia per raccogliere i succhi di cottura o come piastra per cuocere carni, pesci, verdure, focacce, ecc.

TEGLIA*

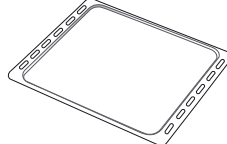

Da usare per cuocere prodotti di panetteria e pasticceria, ma anche carne arrosto, pesce al cartoccio, ecc.

GUIDE SCORREVOLI *

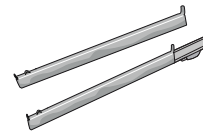

Per facilitare l'inserimento o la rimozione degli accessori.

* Disponibile solo su alcuni modelli.

Il numero e il tipo di accessori possono variare a seconda del modello acquistato. È possibile acquistare separatamente altri accessori presso il Servizio Assistenza.

INSERIRE LA GRIGLIA E ALTRI ACCESSORI

Inserire la griglia orizzontalmente facendola scivolare sulle griglie laterali inserendo dapprima il lato rialzato orientato verso l'alto.

Gli altri accessori, come la leccarda o la piastra dolci, si inseriscono orizzontalmente come la griglia.

TOGLIERE E RIMONTARE LE GRIGLIE LATERALI

- Per togliere le griglie, sollevarle e sganciare la parte inferiore dalla sede tirandola leggermente: a questo punto è possibile rimuovere le griglie.
- Per rimontare le griglie, inserirle dapprima nelle sedi superiori. Avvicinarle alla cavità tenendo sollevato, quindi abbassarle in posizione nelle sedi inferiori.

MONTARE LE GUIDE SCORREVOLI (SE PRESENTI)

Togliere dal forno le griglie laterali e rimuovere la protezione in plastica dalle guide scorrevoli. Ancorare alla griglia laterale la clip superiore della guida e farla scivolare fino a fine corsa; abbassare in posizione l'altra clip. Per fissare la guida, premere la parte inferiore della clip contro la griglia laterale. Assicurarsi che le guide possano scorrere liberamente. Ripetere questa operazione sull'altra griglia laterale, allo stesso livello.

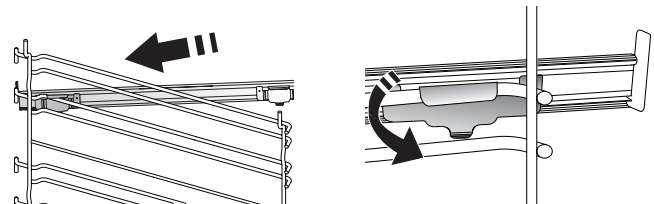

Nota: Le guide scorrevoli possono essere montate su qualsiasi livello.

PRIMO UTILIZZO

RISCALDARE IL FORNO

Un nuovo forno può rilasciare degli odori dovuti alla lavorazione di fabbrica: questo è normale. Prima di cucinare gli alimenti è dunque raccomandato di riscaldare a vuoto il forno per rimuovere ogni odore. Rimuovere protezioni di cartone o pellicole trasparenti e togliere gli accessori dal forno.

Scaldare il forno a 250 °C per un'ora, utilizzando preferibilmente la funzione "Ventilato". Durante questa procedura il forno deve essere vuoto. Seguire le istruzioni a seguire per impostare correttamente la funzione.

Nota: è opportuno ventilare la stanza durante e dopo il primo utilizzo.

FUNZIONI E USO QUOTIDIANO

1. SELEZIONARE UNA FUNZIONE

Per selezionare una funzione, ruotare la *manopola di selezione* in corrispondenza del simbolo della funzione desiderata.

-  OFF
Per spegnere il forno.
-  LAMPADA
Per accendere la luce del forno.
-  STATICO
Per cuocere qualsiasi tipo di pietanza su un solo ripiano.
-  DIAMOND CLEAN (solo in alcuni modelli)
L'azione del vapore rilasciato durante questo speciale ciclo di pulizia a bassa temperatura permette di rimuovere facilmente sporco e residui di cibo. Attivare la funzione quando il forno è freddo, dopo aver versato 200ml di acqua nel fondo della cavità del forno. Selezionare 30 minuti a una temperatura di 90°C. Alla fine del ciclo, attendere circa 15 minuti prima di aprire la porta.
-  VENTILATO
Per cuocere carni o torte con ripieno liquido su un solo ripiano. Questa funzione permette di ottenere superficie e base uniformemente dorate e croccanti.
-  GRILL
Per grigliare costate, spiedini e salsicce, gratinare verdure o dorare il pane. Per la grigliatura delle carni, si consiglia di utilizzare una leccarda per raccogliere il liquido di cottura: posizionarla un livello sotto la griglia e aggiungere 500 ml di acqua potabile.
-  TURBO GRILL
Per arrostiti grossi pezzi di carne (cosciotti, roast beef, polli). Si consiglia di utilizzare una leccarda per raccogliere il liquido di cottura: posizionarla un livello sotto la griglia e aggiungere 500 ml di acqua potabile. Con questa funzione è possibile utilizzare il girarrosto (se presente).
-  SCONGELAMENTO
Per velocizzare lo scongelamento degli alimenti.
-  TERMOVENTILATO
Per cuocere contemporaneamente su più ripiani (massimo tre) alimenti diversi che richiedono la medesima temperatura di cottura.
-  RISCALDAMENTO DAL BASSO
Indicato per dorare la base delle pietanze. Questa funzione è consigliata anche per la cottura

lenta, per terminare la cottura di pietanze in umido e per la preparazione di salse concentrate.

2. AVVIARE UNA FUNZIONE

Per avviare la funzione selezionata, ruotare la *manopola termostato* per impostare la temperatura desiderata.

Utilizzando la *manopola timer* è possibile impostare il tempo di cottura tra 1 e 120 minuti. Ruotare completamente la *manopola timer* in senso orario, quindi selezionare la durata desiderata ruotandola in senso antiorario.

Al termine della durata impostata il forno si spegne automaticamente, mentre la *manopola timer* rimane posizionata su 0. Per utilizzare il forno in modalità manuale, portare la *manopola timer* su .

Nota: se la *manopola timer* è posizionata su 0, non è possibile avviare nessuna funzione.

Per interrompere una funzione in qualsiasi momento, spegnere il forno, ruotare la *manopola di selezione* e la *manopola del termostato* su 0 e .

DIAMOND CLEAN (se presente)
Per attivare la funzione di pulizia "Diamond Clean", versare 200 ml di acqua potabile sul fondo del forno, quindi ruotare la *manopola di selezione* e la *manopola termostato* in corrispondenza dell'icona .

3. PRERISCALDAMENTO











Una volta avviata la funzione, il LED del termostato si accende per segnalare che si è attivata la fase di preriscaldamento.

Al termine di questa fase, il LED del termostato si spegne ad indicare che il forno ha raggiunto la temperatura impostata: a questo punto, inserire gli alimenti e procedere alla cottura.

Nota: inserire gli alimenti nel forno prima della fine del preriscaldamento può compromettere i risultati di cottura.

TABELLA DI COTTURA











RICETTA	FUNZIONE	PRERISC.	TEMPERATURA (°C)	DURATA (MIN)	RIPIANO E ACCESSORI
Torte lievitate / Pan di Spagna		Si	150 - 175	35 - 90	3
		Si	150 - 170	30 - 90	4 1
Torte ripiene (cheesecake, strudel, apple pie)		Si	150 - 190	30 - 85	3
		Si	150 - 190	35 - 90	4 1
Biscotti / Crostatine		Si	160 - 175	20 - 45	3
		Si	150 - 175	20 - 45	4 1
Bigné		Si	175 - 200	30 - 40	3
		Si	170 - 190	35 - 45	4 1
Meringhe		Si	100	110 - 150	3
		Si	100	130 - 150	4 1
Pane / Pizza / Focaccia		Si	190 - 250	12 - 50	3
		Si	190 - 250	20 - 50	4 1
Pizze surgelate		Si	250	10 - 15	3
		Si	250	10 - 20	4 1
Torte salate (torta di verdure, quiche)		Si	175 - 200	35 - 55	3
		Si	175 - 190	45 - 60	4 1
Vols-au-vent / Salatini di pasta sfoglia		Si	175 - 200	20 - 30	3
		Si	175 - 190	25 - 45	4 1
Lasagne / Flan / Cannelloni / Sformati		Si	200	45 - 65	3
Agnello / Vitello / Manzo / Maiale 1 kg		Si	200	80 - 110	3
Pollo / Coniglio / Anatra 1 kg		Si	200	50 - 100	3
Tacchino / Oca 3 kg		Si	200	80 - 130	2
Pesce al forno / al cartoccio (filetti, intero)		Si	175 - 200	40 - 60	3
Verdure ripiene (pomodori, zucchine, melanzane)		Si	175 - 200	50 - 60	2
Pollo arrosto 1-1,3 kg		-	200	55 - 70 *	2 1
Pane tostato		-	200	2 - 5	5
Filetti / Tranci di pesce		-	200	20 - 30 *	4 3
Salsicce / Spiedini / Costine / Hamburger		-	200	30 - 40 *	5 4
Roast beef al sangue 1 kg		-	200	35 - 45 **	3
Cosciotto d'agnello / Stinco		-	200	60 - 90 **	3
Patate arrosto		-	200	45 - 55 **	3

RICETTA	FUNZIONE	PRERISC.	TEMPERATURA (°C)	DURATA (MIN)	RIPIANO E ACCESSORI
Verdure gratinate		—	200	20 - 30	3 
Lasagne e carne		Sì	200	50 - 100 ***	4 1  
Carne e patate		Sì	200	45 - 100 ***	4 1  
Pesce e verdure		Sì	175	30 - 50 ***	4 1  

* Ruotare il cibo a metà cottura.

** Ruotare il cibo a due terzi di cottura se necessario.

*** La durata è approssimata: le pietanze possono essere tolte dal forno in tempi differenti secondo preferenza.

FUNZIONI	 Statico	 Grill	 Turbo Grill	 Ventilato	 Termoventilato
ACCESSORI	 Griglia	 Pirofila o tortiera su griglia	 Leccarda / piastra dolci o teglia su griglia	 Leccarda / teglia	 Leccarda con 500 ml di acqua

CONSIGLI UTILI

COME LEGGERE LA TABELLA DI COTTURA

La tabella indica la funzione, gli accessori e il livello migliore da utilizzare per cuocere svariati tipi di cibo. I tempi di cottura iniziano dall'introduzione degli alimenti nel forno, escluso il preriscaldamento (dove richiesto). Le temperature e i tempi di cottura sono indicativi e dipendono dalla quantità di cibo e dal tipo di accessori. Utilizzare inizialmente i valori più bassi consigliati e, se il risultato della cottura non è quello desiderato, passare a quelli più alti. Si consiglia di utilizzare gli accessori in dotazione e tortiere o teglie possibilmente in metallo scuro. È possibile utilizzare anche pentole e accessori in pirex o in ceramica, ma i tempi di cottura si allungheranno leggermente.

COTTURA SIMULTANEA DI ALIMENTI DIVERSI

Utilizzando la funzione "Termoventilato", è possibile cuocere contemporaneamente alimenti diversi (ad esempio: pesce e verdure), su ripiani diversi. Si potranno estrarre prima gli alimenti che richiedono tempi di cottura più brevi e lasciare continuare la cottura per quelli che necessitano di tempi più lunghi.

PULIZIA E MANUTENZIONE

Assicurarsi che il forno si sia raffreddato prima di eseguire ogni operazione. Non utilizzare pulitrici a getto di vapore.

Non usare pagliette metalliche, panni abrasivi e detergenti abrasivi o corrosivi che possano danneggiare le superfici. Utilizzare guanti protettivi.

Il forno deve essere disconnesso dalla rete elettrica prima di effettuare operazioni di manutenzione.

SUPERFICI ESTERNE

• Pulire le superfici con un panno in microfibra umido. Se molto sporche, aggiungere qualche goccia di detergente neutro. Asciugare con un panno asciutto.

• Non usare detergenti corrosivi o abrasivi. Se inavvertitamente uno di questi prodotti dovesse venire a contatto con le superfici, pulire subito con un panno in microfibra umido.

SUPERFICI INTERNE

• Dopo ogni uso, lasciare raffreddare il forno e pulirlo preferibilmente quando è ancora tiepido per rimuovere incrostazioni e macchie dovute a residui di cibo; per asciugare la condensa dovuta alla cottura di alimenti con un elevato contenuto di acqua, usare a forno freddo un panno o una spugna.

• Attivare la funzione "Diamond Clean" per una pulizia ottimale delle superfici interne. (Se presente).
• Pulire i vetri della porta con detergenti liquidi specifici.
• Per facilitare la pulizia della porta è possibile rimuoverla .

ACCESSORI

• Mettere a bagno gli accessori con detersivo per piatti dopo l'uso, maneggiandoli con guanti da forno, se ancora caldi. I residui di cibo possono essere rimossi con una spazzola per piatti o con una spugna.

PULIZIA DEI PANNELLI CATALITICI

(SOLO IN ALCUNI MODELLI)

Questo forno può essere equipaggiato con degli speciali pannelli catalitici che facilitano la pulizia della cavità grazie a un particolare rivestimento autopulente ad alta porosità, in grado di catturare lo sporco. Questi pannelli sono montati sulle griglie laterali: quando queste vengono rimontate, per un corretto posizionamento, assicurarsi che l'aggancio superiore delle griglie sia infilato negli appositi fori dei pannelli.

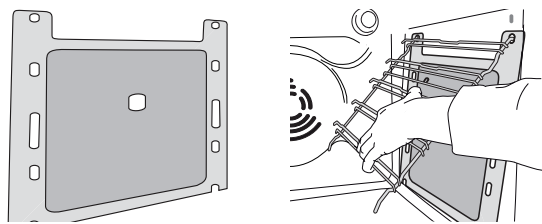

Per utilizzare al meglio le proprietà autopulenti, Si consiglia di riscaldare il forno a 200°C per circa 1 ora utilizzando la funzione "Ventilato". Durante questa procedura il forno deve essere vuoto. Lasciare quindi raffreddare il forno e infine rimuovere eventuali residui di alimenti con una spugna non abrasiva.

Nota: l'uso di detergenti corrosivi o abrasivi, spazzole ruvide, spugne abrasive per pentole o spray per forno possono danneggiare la superficie catalitica, facendole perdere le sue particolari proprietà. Nel caso fosse necessaria la sostituzione dei pannelli, rivolgersi al Servizio Assistenza.

SOSTITUZIONE DELLA LAMPADA

1. Scollegare il forno dalla rete elettrica.
2. Svitare la copertura della lampada, sostituire la lampada e avvitare di nuovo il coperchio della lampada.
3. Ricollegare il forno alla rete elettrica.

Nota: usare solo lampade alogene da 20-40 W/230 ~ V tipo G9, T 300 °C. La lampada utilizzata nel prodotto è specifica per elettrodomestici e non è adatta per l'illuminazione di ambienti domestici (Regolamento (CE) 244/2009). Le lampadine sono disponibili presso il Servizio Assistenza.

- In caso di impiego di lampade alogene, non maneggiarle a mani nude, per evitare che vengano danneggiate dalle impronte digitali. Non far funzionare il forno senza prima aver riposizionato il coperchio.

ABBASSARE LA RESISTENZA SUPERIORE

(SOLO IN ALCUNI MODELLI)

1. Rimuovere le griglie laterali.

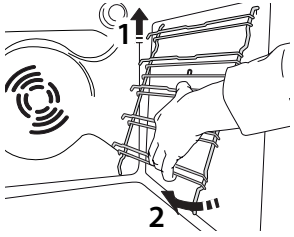

2. Estrarre leggermente la resistenza e abbassarla.

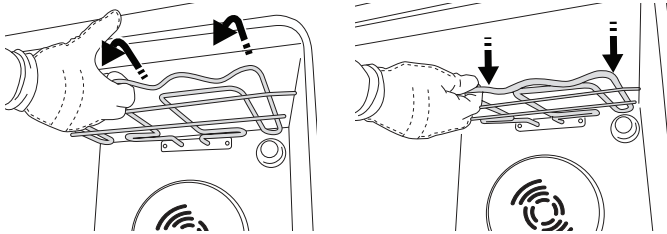

3. Per riposizionare la resistenza, sollevarla, tirandola leggermente verso di sé, assicurandosi che poggia sulle apposite sedi laterali.

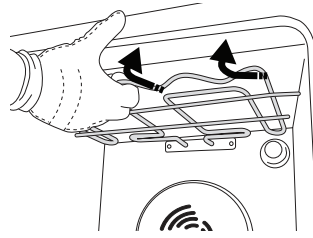
**TOGLIERE E RIMONTARE LA PORTA**

1. Per rimuovere la porta, aprirla completamente e abbassare i fermi fino alla posizione di sblocco.

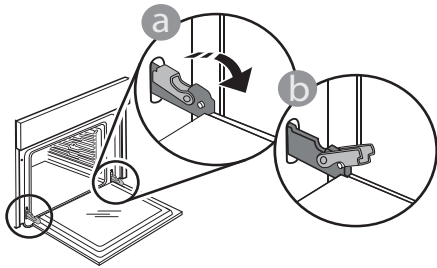

2. Chiudere la porta fino a quando è possibile. Prendere saldamente la porta con entrambe le mani, evitando di tenerla per la maniglia. Per estrarla facilmente, continuare a chiuderla e contemporaneamente tirarla verso l'alto finché non esce dalle sedi. Togliere la porta e appoggiarla su un piano morbido.

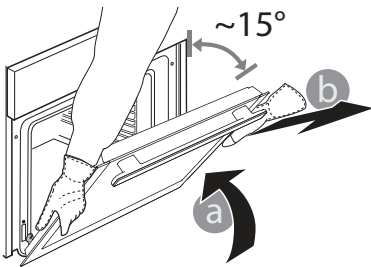

3. Per rimontare la porta, avvicinarla al forno allineando i ganci delle cerniere alle proprie sedi e ancorare la parte superiore agli alloggiamenti.
4. Abbassare la porta e poi aprirla completamente. Abbassare i fermi nella posizione originale: fare attenzione che siano completamente abbassati.

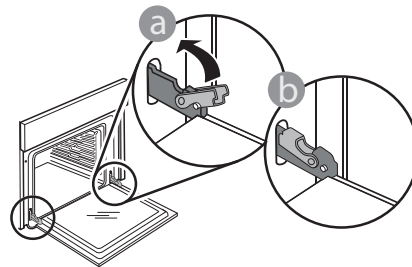

Sarà necessario applicare una leggera pressione per assicurare il corretto posizionamento dei fermi (solo in alcuni modelli).

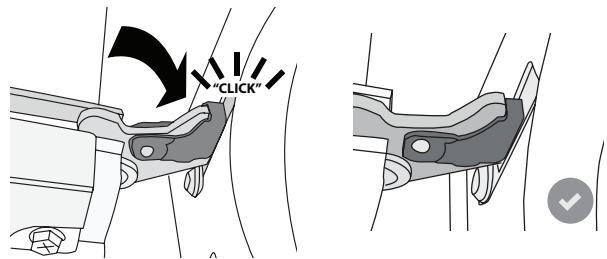

5. Provare a chiudere la porta, verificando che sia allineata al pannello di controllo. Se non lo fosse, ripetere tutte le operazioni: funzionando male, la porta potrebbe danneggiarsi.

RISOLUZIONE DEI PROBLEMI

Problema	Possibile causa	Soluzione
Il forno non funziona.	Interruzione di corrente elettrica. Disconnessione dalla rete principale.	Verificare che ci sia tensione in rete e che il forno sia collegato all'alimentazione elettrica. Spegnere e riaccendere il forno e verificare se l'inconveniente persiste.
La cottura non si avvia.	Manopola timer in posizione 0 .	Ruotare la manopola timer su  oppure selezionare una durata come indicato nel capitolo "Uso quotidiano".
La porta non si chiude correttamente.	I fermi di sicurezza si trovano in posizione errata.	Verificare che i fermi di sicurezza siano in posizione corretta facendo riferimento alle istruzioni di rimozione e riapplicazione della porta contenute nella sezione "Pulizia e manutenzione".

SCHEDA TECNICA

 [www](http://www.docs.hotpoint.eu) La scheda del prodotto comprensiva dei dati energetici di questo forno può essere scaricata dal sito internet **docs.hotpoint.eu**

COME OTTENERE LE ISTRUZIONI PER L'USO

>  [www](http://www.docs.hotpoint.eu) Scaricare le Istruzioni per l'uso dal sito web **docs.hotpoint.eu** (è possibile utilizzare questo codice QR) specificando il codice prodotto.



> In alternativa, contattare il Servizio di Assistenza Clienti.

CONTATTARE IL SERVIZIO ASSISTENZA CLIENTI

I contatti possono essere trovati sul manuale di garanzia. Quando si contatta il Servizio Assistenza, fornire i codici presenti sulla targhetta matricola del prodotto.

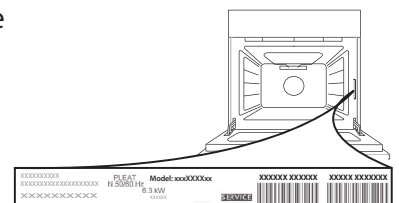

400011713979