

# AKZM 6540/IXL

12NC: 852565438110

GTIN (EAN) code: 8003437827556

Whirlpool

SENSING THE DIFFERENCE

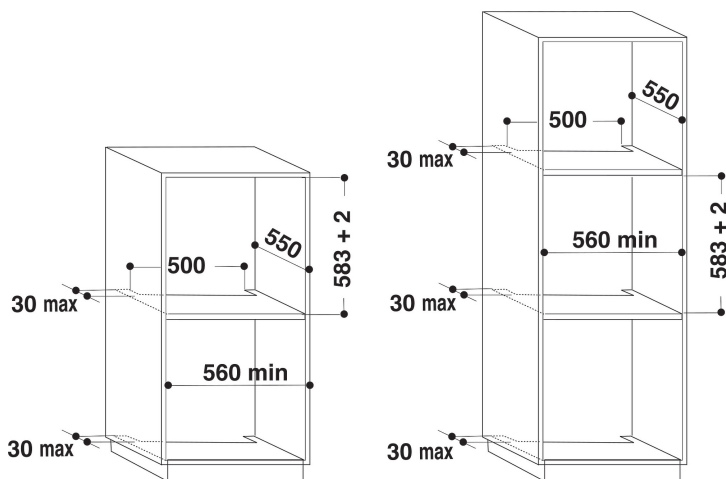

- Energy class A+
- Cavity 73 L
- Cook3
- Ready2Cook
- Defrost function
- Forced Air Fan Cooking
- Grill
- Easy Clean Enamel Interior
- Turbo grill function
- Maxi cooking
- Pastry function
- Soft closing door
- Special functions
- Fast Pre-Heating
- Tilting Grill for easy cleaning
- Conventional Cooking
- "Push Push" knobs

## Whirlpool built in electric oven: inox color - AKZM 6540/IXL

This Whirlpool built in Oven features: advanced electric technology allowing you to cook dishes saving energy. Halogen lamp allowing a more energy-efficient performance. Innovative Cook3 function, that allows you to cook up to three separate dishes at the same time, without the risk of aromas mixing. Oven door with soft-close design, for increased ease of use. Ready2Cook function, that uses a powerful convection system to quickly reach the right temperature, and completely eliminate pre-heating need.



### Ready2cook

No pre-heating required. The Ready2Cook function uses a powerful convection system to quickly reach the right temperature, and completely eliminate the need for pre-heating.



### Cook3

No aroma mixing. With the innovative Cook3 function, you can cook up to three separate dishes at the same time, without the risk of aromas mixing.



### LCD graphic assisted display

An intuitive LCD graphic display to assist you during cooking. It includes 9 special functions to help streamline your recipes.



### Ixelium

Long lasting beauty. The revolutionary iXelium nanotechnology treatment protects your oven from scratches and ensures a perfect shine, always. And it's easy to clean: all you need is water and a soft cloth.



### Soft closing

Slow-motion closing. Thanks to slow-closing hinges, the oven door shuts effortlessly, with a soft and silent motion.



### Easy to clean

Easy to clean. To clean your oven, simply use warm water and a soft cloth, no need to use harsh chemicals or cleaners.



### XXL cavity

All the space you need. The XXL cavity in your oven has a capacity of 75 litres with 5 different shelf positions available.



### Energy class

Outstanding energy savings. Ovens with an A/ A+ energy rating offer an excellent level of energy efficiency, ensuring lower consumption and saving you money on your energy bills.

# AKZM 6540/IXL

12NC: 852565438110

GTIN (EAN) code: 8003437827556

# Whirlpool

SENSING THE DIFFERENCE

## MAIN FEATURES

Product group	Oven
Commercial code	AKZM 6540/IXL
Main colour of product	Inox
Construction type	Built-in
Type of control	Mechanical and electronic
Type of control settings	-
Are any hobs controls integrated?	No
Which kind of hobs can be controlled?	-
Automatic programmes	Yes
Current (A)	13
Voltage (V)	220-240
Frequency (Hz)	50
Length of Electrical Supply Cord (cm)	90
Plug type	No
Depth with open door 90 degree (mm)	-
Height of the product	595
Width of the product	595
Depth of the product	564
Minimum niche height	0
Minimum niche width	0
Niche depth	0
Net weight (kg)	35.5
Usable volume (of cavity)	73
Integrated Cleaning system	No
Grids of the cavity	2
Trays	1

## TECHNICAL FEATURES

Timer	-
Time control	Electronic
Time-setting options	Start and Stop
Safety device	-
Interior light	Yes
Number of interior lights of the cavity	1
Position of interior lights of the cavity	Rear
Oven guides of the cavity	Grids
Probe of the cavity	No

## PERFORMANCES

Energy input	Electric
Type of energy of the cavity	Electricity
Energy efficiency class - NEW (2010/30/EU)	A+
Energy consumption per cycle conventional - NEW (2010/30/EU)	0.91
Energy consumption per cycle forced air convection - NEW (2010/30/EU)	0.7



**ENERG** Y UA  
енергия · ενεργεια IE 1A

**WHIRLPOOL** AKZM 6540/IXL



A+



**73** L



**0.91** kWh/cycle\*



**0.7** kWh/cycle\*

\* цистерна · cylindus · partion · zylinder · mpolytupou · cido · tsükkel · ohjelma · ciklus · cikls · ciklu · cycles · cykl · ciclu · program · cykel

65/2014