

ACM 712/IX

12NC: 857671201000

GTIN (EAN) code: 8003437818264

Whirlpool

SENSING THE DIFFERENCE

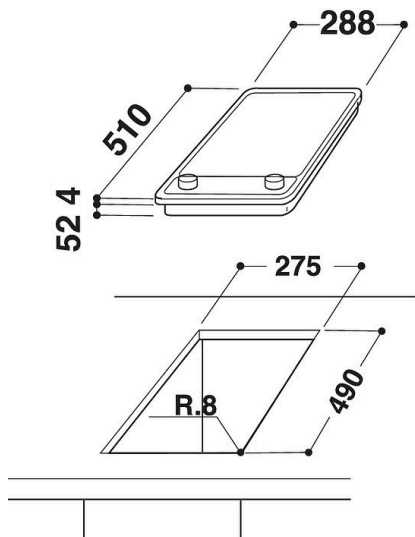
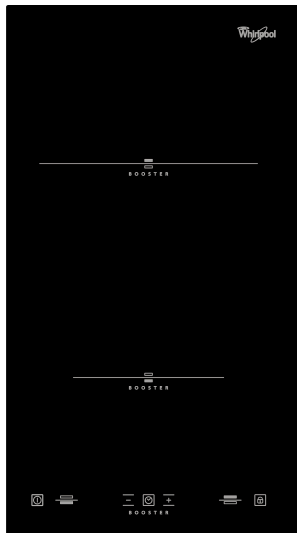

- 2 induction cooking zones
- FlexiCook
- Residual heat indicator
- Child lock
- On/Off Switch
- 30 cm hob
- Timer
- Black Glass Hob
- 2 Boosters
- Power on indicator
- Supply cord included
- Power manager: maximum power setting 2,5 kW/4 kW/6 kW/7,4 kW
- Dimensions HxWxD: 56x288x510 mm
- Niche dimensions HxWxD: 52x275x490 mm
- Electrical Connection Rating: 3000 W
- Voltage: 230 V

Whirlpool induction glass-ceramic hob - ACM 712/IX

2 induction rings. flexiCook zone technology, allowing you to combine multiple burners into a single cooking zone, for larger pots and pans. This Whirlpool induction glass-ceramic Hob features: An elegant technology, that heats the pan, not the hob, reducing energy dispersion and providing perfect cooking results. Electric power supply.



Induction technology

Faster, energy-efficient cooking. Induction technology heats the pan, not the hob, reducing energy dispersion by 10%, and providing perfect cooking results.



FlexiCook

Flexibility and performance. FlexiCook provides flexible cooking space for pots and pans of any size.



Power management

Outstanding energy efficiency. With the Power Management function, you set the hob's power level, to avoid the risk of overloading the power supply in your home.



Flexible Cooking

Automatic power settings. Select the cooking function on your touch display and your hob will automatically adjust the power level accordingly.



Front Controls

Complete control over your cooking. Easily accessible and genuinely intuitive, the controls are conveniently positioned on the front panel of your hob, providing a frictionless cooking experience.



Booster

Enjoy super fast boiling times with the Booster cooking zone.



Booster 3Kw

Enjoy ideal results, faster. This Whirlpool Hob features a 3Kw booster for faster, effective heating results.



Touch control

Cooking at the press of a button. Thanks to TouchControl, the precise control of your hobs is at your finger tips. The sensor power regulation does without the 10 phases on most dials and thus allows for simpler cleaning and care for your hob.

ACM 712/IX

12NC: 857671201000

GTIN (EAN) code: 8003437818264

Whirlpool

SENSING THE DIFFERENCE

MAIN FEATURES

| | |
|---------------------------------------|------------|
| Product group | Hob |
| Construction type | Built-in |
| Type of control | Electronic |
| Type of control settings | - |
| Number of gas burners | 0 |
| Number of electric cooking zones | 2 |
| Number of electric plates | 0 |
| Number of radiant plates | 0 |
| Number of halogen plates | 0 |
| Number of induction plates | 2 |
| Number of electric warming zones | 0 |
| Location of control panel | Front |
| Basic surface material | Glass |
| Main colour of product | Black |
| Electrical connection rating (W) | 3000 |
| Gas connection rating (W) | 0 |
| Gas type | N/A |
| Current (A) | 0,2 |
| Voltage (V) | 230 |
| Frequency (Hz) | 50/60 |
| Length of Electrical Supply Cord (cm) | 120 |
| Plug type | No |
| Gas connection | N/A |
| Width of the product | 288 |
| Height of the product | 56 |
| Depth of the product | 510 |
| Minimum niche height | 52 |
| Minimum niche width | 275 |
| Niche depth | 490 |
| Net weight (kg) | 5.6 |
| Automatic programmes | No |

TECHNICAL FEATURES

| | |
|-------------------------|-----------------------|
| Power on indicator | Yes |
| Number of indicators | 0 |
| Type of regulation | Temperature regulated |
| Type of lid | Without |
| Residual heat indicator | Separate |
| Main on/off switch | Yes |
| Safety device | - |
| Timer | Yes |

PERFORMANCES

| | |
|--------------|----------|
| Energy input | Electric |
|--------------|----------|