

Hotpoint

Refrigerator

User Manual

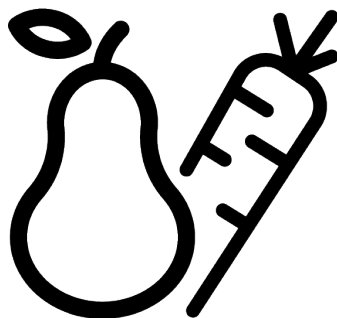

HPK 26412W XP5UK

11 5943 0537/ EN/ AB/ 09.06.26 14:50
7283548827

Please read this manual first!

Our valued customer,

Thank you for choosing product. We want you to get the best results from your product, which is manufactured with high quality and technology. To do this, please read this entire manual and the other documents provided carefully before using the product.

Follow all the information and warnings in the user manual. This will protect you and your product from potential hazards. Keep the user manual. If you give the product to someone else, include the user manual with it.

The following symbols appear in the user manual and on the product:



Read the user manual.



Hazard that may result in death or injury.

 ENERG  	The model information as stored in the product data base can be reached by entering following website and searching for your model identifier (*) found on energy label. https://eprel.ec.europa.eu/
SUPPLIER'S NAME MODEL IDENTIFIER → (*)	
 	

Table of Contents

1 Safety Instructions	4	7.11 Energy Management.....	27
1.1 Important Safety Symbols	4	7.12 Using the Water Dispenser.....	28
1.2 Intention of Use	4	8 Maintenance and Cleaning	30
1.3 Safety of Children, Vulnerable Persons and Pets	5	9 Troubleshooting	32
1.4 Electrical Safety	5		
1.5 Handling Safety	6		
1.6 Installation Safety.....	6		
1.7 Operational Safety.....	9		
1.8 Food Storage Safety.....	12		
1.9 Maintenance and Cleaning Safety	13		
1.10 Lighting	14		
1.11 Disposal of the Old Product.....	14		
1.12 Technical Information About Bluetooth + Wi-fi	15		
2 Environmental Instructions	15		
2.1 Compliance with the WEEE Dir- ective and Disposing of the Waste Product	15		
3 Your Refrigerator	16		
4 Installation	17		
4.1 Right Place For Installation.....	17		
4.2 Adjusting the Legs.....	17		
4.3 Hot Surface Warning	17		
5 Preparation	17		
5.1 What To Do For Energy Saving	17		
5.2 First Use	18		
5.3 Climate Class and Definitions	18		
6 Operating the Product	19		
7 Use of Your Appliance	20		
7.1 Control Panel of the Product	20		
7.1.1 High Temperature Alarm.....	22		
7.2 Food Storage in Refrigerator	22		
7.3 Crispers/Fresh food compart- ment	26		
7.4 Crisper Technologies	26		
7.5 Dairy Products Cold Storage Area	26		
7.6 Reversing the Door Opening Side.	26		
7.7 Door Open Alert	27		
7.8 Replacing the Illumination Lamp..	27		
7.9 Active Check	27		
7.10 Artificial Intelligence (AI) Techno- logy	27		

1 Safety Instructions

- This section includes the safety instructions necessary to prevent the risk of personal injury or material damage.
- Our company shall not be held responsible for damages that may occur if these instructions are not observed.
- Always have installation and repair operations performed by manufacturer, authorized service or a person who will be described by importer company.
- Use original spare parts and accessories only.
- Do not repair or replace any component of the product unless it is clearly specified in the user manual.
- Do not perform any modifications on the product.

1.1 Important Safety Symbols

-  Risk of electric shock!
-  Read the user manual.
-  Danger that may result in burns due to contact with hot surfaces.
-  Combustible material, warning against fire hazard.
-  Risk of injury due to contact with sharp surfaces!

 Risk of UV-C radiation

1.2 Intention of Use

- This product is not suitable for commercial use and should not be used for a purpose other than its intended use.
- This product is intended for operating interiors, such as households or similar.

For example;

In the staff kitchens of the stores, offices and other working environments,

In farm houses,

In the units of hotels, motels or other resting facilities that are used by the customers,

In hostels, or similar environments,

In catering services and similar non-retail applications.

- This product shall not be used in open or enclosed external environments such as vessels, camper vans, balconies or terraces. Exposing the product to rain, snow, sunlight and wind may cause risk of fire.

1.3 Safety of Children, Vulnerable Persons and Pets

- This product may be used by children aged 8 years and older and persons with under-developed physical, sensory or mental capabilities or lack of experience and knowledge if they are being supervised or have been given instruction concerning use of the appliance in a safe way and the hazards involved.
- Children between 3 and 8 years are allowed to put and take out food into/from the cooler product.
- Children and pets must not play with, climb on, or get inside the product.
- Children and pets must be kept away from the cabin area (compressor) where electrical parts are located.
- Cleaning and user maintenance must not be performed by children unless there is someone overseeing them.
- Keep the packaging materials away from children. Risk of injury and suffocation.
- If there is a lock available on the product's door, keep the key out of children's reach.

1.4 Electrical Safety

- The product shall not be plugged into the outlet during installation, maintenance, cleaning, repair, and transportation operations.
- If the power cable is damaged, it must be replaced by the person sent by the manufacturer, authorized service provider or the importer to prevent any potential danger.
- Do not tuck the power cable under the product or to the rear of the product. Do not put heavy items on the power cable. The power cable should not be bent, crushed, and come into contact with any heat source.
- Use an original cable only. Do not use cut or damaged cables.
- Do not use an extension cord, multi-plug or adaptor to operate your product.
- Portable multi-plugs or portable power supplies may overheat and cause fire. Thus, do not have a multi-plug, portable power sources behind or in the vicinity of the product.

- Before plugging the product into the power source, please remove the power cable from the condenser hook (if available) during the installation.
- The user should not be able to reach the electrical parts after installation.
- Do not plug the product's power cord in a loose or damaged power outlet. These types of connections may overheat and cause fire.
- The plug shall be easily accessible. If this is not possible, a mechanism that meets the electrical legislation and that disconnects all terminals from the mains (fuse, switch, main switch, etc.) shall be available on the electrical installation.
- The product must not be operated with an external switching device such as a timer, or a remote controlled system.
- Do not use the product when your feet are bare or your body is wet.
- Do not touch the plug with wet hands.
- When unplugging the appliance, don't hold the power cable, but the plug.
- Make sure that the plug is not wet, dirty or dusty.

- Do not ever connect your product to power saving devices. These systems are harmful for the product.

1.5 Handling Safety

- Make sure to unplug the appliance before carrying the product.
- Make sure to unplug the appliance and remove water connections before carrying the product.
- This product is heavy, do not handle it by yourself. Injuries may occur if the product falls on you. Do not bump into places or drop the product while transporting it.
- Always close the doors and do not hold the product by its doors while transporting it.
- Be careful not to damage the cooling system and the pipes while handling the product. Do not operate the product if the pipes are damaged, and contact an authorized service.

1.6 Installation Safety

- To prepare the product for use, see the information in the user and installation manual and make sure the electric and water utilities are as required. If

not, call a qualified electrician and plumber to arrange the utilities as necessary.

- **Failure to do so may result in electric shock, fire, problems with the product, or injury.**
- Before starting the installation, switch off the fuse to de-energise the power line to which the product is connected.
- The product should be installed by two or more people. Use protective gloves while removing the product from the packaging and installation.
- This product is designed for use at a maximum altitude of 2000 metres above sea level.
- Keep children away from installation area.
- Check for any damage on the product before installing it. Do not have the product installed if it is damaged.
- Always use personal protective equipment (gloves, etc.) during product installation, maintenance and repair. Risk of injury.
- Do not install or leave the product in places where it may be exposed to external ambient temperatures.
- Place the product on a clean, level and hard surface and balance it with the adjustable legs (by rotating the front feet to the right or left). Otherwise, the refrigerator may tip over and cause injuries.
- Proceed with care to prevent causing any damage to the floors (tiling etc.) while moving the product. Install the product on a floor, or provide sufficient support depending on the size, weight and the use-case of the product. Ensure that the product is not near a heat source, and all four feet are stable and leaning against the floor. Install the product as necessary, and ensure that it is horizontal, using a bubble level. To ensure the complete efficiency of the refrigerant circuit, wait for at least two hours before operating the product.
- The product shall be installed in a dry and ventilated environment. Do not keep carpets, rugs or similar covers under the product. This may cause risk of fire as a result of inadequate ventilation!
- Do not block or cover ventilation holes. Otherwise, power consumption increases and your product may be damaged.
- Leave sufficient space by the sides and above to ensure adequate ventilation. The gap between the back panel and the wall behind the product

- must be a minimum of 50mm in order to prevent hot surfaces. Reducing this distance may increase the energy consumption of product.
- When placing the product, make sure that the supply cable is not damaged or pinched.
 - The product must not be connected to supply systems and power sources which may cause sudden voltage changes (i.e. a portable solar-energy power source). Otherwise, damage to your product may occur as a result of the abrupt voltage fluctuations!
 - The more refrigerant a refrigerator contains, the bigger its installation room shall be. In very small rooms, a flammable gas-air mixture may occur in case of a gas leak in the cooling system. At least 1 m³ of volume is required for each 8 grams of refrigerant. The amount of the refrigerant available in your product is specified in the Type Label.
 - The product must never be placed in such a way that power cables, the metal hose of the gas stove, metal gas or water pipes come into contact with the product's rear wall (or the condenser).
 - The installation place of the product must not be exposed to direct sunlight and it shall not be in the vicinity of a heat source such as stoves, radiators, etc. If you cannot prevent installation of the product in the vicinity of a heat source, use a suitable insulation plate and make sure the minimum distance to the heat source is as specified below:
 - At least 30 cm away from heat sources such as stoves, ovens, heating units and heaters, etc.,
 - And at least 5 cm away from electrical ovens.
 - Your product has the protection class of I.
 - Plug the product in a grounded socket that conforms with the Voltage, Current and Frequency values specified in the type label. The socket must have a 10A – 16A fuse. Our firm will not assume responsibility for any damages due to usage without earthing and without power connection in compliance with local and national regulations.
 - The product's power cable must be unplugged during installation. Otherwise, risk of electric shock and injury may occur!

- Do not plug the product to loose, broken, dirty, greasy sockets or sockets that have come out of their seats or sockets with a risk of water contact. These types of connections may overheat and cause fire.
- Place the power cable and hoses (if any) of the product so that they shall not cause a risk of tripping over.
- Penetration of humidity and liquid to live parts or to the power cord may cause short circuit. Thus, do not use the product in humid environments or in areas where water may splash (e.g. garage, laundry room, etc.) If the refrigerator is wet by water, unplug it and contact an authorized service.
- Do not ever connect your refrigerator to power saving devices. These systems are harmful for the product.
- There is a risk of contact with electrical parts when removing the electronic board cover and the compressor rear cover (if fitted). Do not remove the electronic board cover and the compressor rear cover (if fitted). There is a risk of electrocution!

1.7 Operational Safety

- Do not ever use chemical solvents on the product. These materials contain an explosion risk.
- In case of a failure of the product, unplug it (or de-energise the fuse to which it is connected), and do not operate until it is repaired by the authorized service. There is a risk of electric shock!
- Do not place flames (lighted candle, cigarette, etc.) or heat sources (iron, hob, oven, etc.) on or near the product. Do not place flammable/explosive materials near the product...
- Do not get on the product. Risk of falling and injury!
- Do not cause damage to the pipes of the cooling system using sharp and piercing tools. The refrigerant that sprays out in case of puncturing the gas pipes, pipe extensions or upper surface coatings may cause irritation of skin and injury to the eyes.
- Do not intervene in or damage the coolant circuit Risk of explosion.
- Do not place and operate electrical appliances inside the refrigerator/freezer unless it is advised by the manufacturer.

- Do not use any procedures other than those recommended by the manufacturer to speed up defrosting.
- Take due care not to jam any parts of your hands or your body to the moving parts inside the product. Be careful to prevent jamming of your fingers between the refrigerator and its door. Be careful while opening or closing the door if there are children around.
- Do not put ice cream, ice cubes or frozen food to your mouth as soon as you take them out of the freezer. Risk of frostbite!
- Do not touch the inner walls, metal parts of the freezer or food kept inside the freezer with wet hands. Risk of frostbite!
- Do not place soda cans or cans and bottles that contain fluids that may be frozen to the freezer compartment. Cans or bottles may explode. Risk of injury and material damage!
- Do not use or place materials sensitive against temperature such as flammable sprays, flammable objects, dry ice or other chemical agents in the vicinity of the refrigerator. Risk of fire and explosion!
- Do not store explosive materials such as aerosol cans with flammable materials inside the product.
- Do not place cans containing fluids over the product an open state. Splashing of water on an electrical part may cause an electric shock or a fire.
- Due to risk of breaking, do not store glass containers with liquid inside in the freezer compartment.
- This product is not intended for storage and cooling of medicines, blood plasma, laboratory preparations or similar materials and products that are subject to the Medical Products Directive.
- If the product is used against its intended purpose, it may cause damage to or deterioration of the products stored inside.
- If your refrigerator is equipped with blue light, do not look at this light with optical devices. Do not stare directly at UV LED light for a long time. Ultraviolet rays may cause eye strain.
- Do not fill the product with more contents than its capacity. Do not use any procedures other than those recommended by the manufacturer to speed up defrosting. Injuries

or damages may occur if the contents of the refrigerator fall when the door is opened. Similar problems may also occur when an object is placed over the product.

- Ensure that you have removed any ice or water that may have fallen to the floor to prevent injuries.
- Change the locations of the racks/bottle racks on the door of your refrigerator only when the racks are empty. Danger of injury!
- Do not place objects that may fall/tip over on the product. These objects may fall while opening or closing the door and cause injuries and/or material damages.
- Do not hit or exert excessive pressure on glass surfaces. Broken glass may cause injuries and/or material damages.
- For products designed to use an air filter inside an accessible fan cover, the filter must always be in position when the refrigerator is in function.
- Do not block out the fan (if available) with food.
- Damaged gaskets should be replaced as soon as possible.
- The cooling system in your product contains R600a refrigerant. The refrigerant type

used in the product is specified in the type label. This gas is flammable. Therefore, be careful not to damage the cooling system and the pipes while operating the product. In case of damage to the pipes;

1. Do not touch the product or the power cable.
 2. Keep the product away from potential sources of fire that may cause the product to catch fire.
 3. Ventilate the area where the product is placed. Do not use a fan.
 4. Contact Authorized Service.
- Before disposing of old products that shall not be used any more:
1. Unplug the power cord from the mains socket.
 2. Cut the power cable and remove it from the appliance together with the plug.
 3. Do not remove the racks and drawers from the product to prevent children from getting inside the appliance.
 4. Remove the doors.
 5. Store the product so that it shall not be tipped over.
 6. Do not allow children to play with the scrapped product.

7. If the product is damaged and you observe gas leak, please stay away from the gas. Gas may cause frostbite if it contacts your skin.
- Do not dispose of the product by throwing it into fire. Risk of explosion.
 - If there is a lock available on the product's door, keep the key out of children's reach.

For Products with Water Dispenser / Icematic

- Use only drinking water. Do not fill the water tank with fruit juice, milk, fizzy beverages, alcoholic beverages or any other liquids incompatible for use in the water dispenser. This may cause risk to your health and safety.
 - Do not allow the children to play with the water dispenser or icematic to prevent accidents and injuries.
 - Do not insert your hands, fingers or other objects inside the hole of the water dispenser, ice channel or inside the container of the icematic. This may cause injuries or material damages.
 - The hose sets supplied with the product shall be used. Do not use the old hose sets. Do not extend the hoses!
- Always connect your product to cold water inlet. Do not perform installation on the hot water inlet. The pressure for the cold water inlet shall be 90 PSi (620 kPa – 6.2 bar) maximum. If your water pressure exceeds 80PSi (550 kPa – 5.5 bar) or has a water impact effect, use a pressure limiting valve on your mains system. Ask help from professional plumbers if you do not know how to control your water pressure.
 - High pressure may cause damage to the hose connections and pose a risk of flooding.
 - Take required precautions against the risk of freezing of hoses. The operating water temperature interval shall be 0.6°C (33°F) minimum and 38°C (100°F) maximum. There is a risk of flooding if the hose is cracked/perforated.



1.8 Food Storage Safety

Please pay attention to the following warnings to avoid food spoilage:

- Leaving the doors open for a long time may cause the temperature inside the product to rise.

- Regularly clean the accessible drainage systems in contact with food.
- Clean the water tanks that have not been used for 48 hours and mains-fed water systems that have not been used for more than 5 days.
- Store raw meat and fish products in dairy/chill compartment within the product. Thus, it does not drip on or come into contact with other foods.
- Two-star compartments are used for storing pre-filled foods, making and storing ice and ice cream.
- One, two and three-star compartments are not appropriate for freezing fresh food.
- If the cooling product has been left empty for a long time, turn off the product, defrost, clean, and dry the product in order to protect the housing of the product.
- After the foods are placed, check if the compartment hatches, and especially the freezer door, are properly closed.
- Use the Crispers/Fresh food compartment for storing fresh foods, and the freezer com-

partment for storing frozen goods, freezing fresh foods and preparing ice cubes.

- Do not store foods without properly sealing them in the refrigerator and the freezer compartments, to prevent direct contact with the inner surfaces.



1.9 Maintenance and Cleaning Safety

- Unplug the refrigerator or de-energise the fuse before cleaning it or starting to perform maintenance.
- Do not pull by the door or door handle if you are going to move the product for cleaning purposes. The door may cause injuries if the handle is pulled too hard.
- Do not place hands, feet or metal objects under or behind your product. Jamming may occur or any sharp edge may cause personal injuries.
- Do not wash the inside or outside of the product with a pressure washer, steam, spray water or pouring water. Risk of electric shock and fire.
- When cleaning the product, do not use sharp and abrasive tools or household cleaning agents, detergent, gas, gasoline, thinner, alcohol, varnish,

and similar substances. Use only cleaning and maintenance agents that are not harmful for food inside the product.

- Do not use paper towels, kitchen sponges or other hard cleaning materials.
- Do not ever use steam or steamed cleaning materials for cleaning the product and thawing the ice inside it. Steam contacts the live areas in your refrigerator and causes short circuit or electric shock.
- Do not use any mechanical tools or any other tools than the recommendations of the manufacturer to speed up the thawing operation.
- Take care to keep water away from the ventilation holes, electronic circuits or lighting of the product. Otherwise, risk of fire or electric shock may occur.
- Use a clean, dry cloth to wipe the dust or foreign material on the tips of the plugs. Do not use a wet or damp piece of cloth to clean the plug. Otherwise, risk of fire or electric shock may occur.

1.10 Lighting

Contact an authorized service when you shall replace the LED / bulb using for lighting.

1.11 Disposal of the Old Product

When disposing of your old product follow the instructions below:

- To prevent children from accidentally locking themselves into the product, if there is door lock, disable it.
- Splash of coolant is harmful to the eyes. Do not damage any part of the cooling system while disposing of the product.
- It may be fatal if the compressor oil is swallowed or if it penetrates the respiratory tract.
- Cooling system of your product includes R600a gas as specified in the type label. This gas is flammable. Do not dispose of the product by throwing it into fire. Risk of explosion!
- C-Pentane is used as a blowing agent in insulation foam and it is a flammable substance. Do not dispose of the product by throwing it into fire.

! 1.12 Technical Information About Bluetooth + Wi-fi

Frequency Band:	2.4GHz (Wi-fi or bluetooth function)
Max. Transferring Power:	< 100mW (Wi-fi or bluetooth function)
Software Details:	Quartz_WiFi.XXX

SIMPLIFIED EU DECLARATION OF CONFORMITY:

Hereby, Beko Europe Management S.R.L.declares that the radio equipment is in compliance with Directive 2014/53/EU. The full text of the EU declaration of conformity is available at the following internet address:<https://docs.emeaappliance-docs.eu>

This product collects and transmits usage data when connected to the internet (e.g. temperature settings, usage duration, error codes **etc.**). In accordance with the EU Data Act (Regulation EU 2023/2854), you have the right to access and manage this data.

For details on what data is collected, how it is used, and how to access it, please visit:www.home-whiz.com/eu-data-act-policy

2 Environmental Instructions

2.1 Compliance with the WEEE Directive and Disposing of the Waste Product



This product complies with EU WEEE Directive (2012/19/EU). This product bears a classification symbol for waste electrical and electronic equipment (WEEE).

This symbol indicates that this product shall not be disposed with other household wastes at the end of its service life. Used device must be returned to official collection point for recycling of electrical and electronic devices. To find these collection systems please contact to your local authorities or retailer where the product was purchased. Each household performs important role in recovering and recycling of old appliance. Appropriate disposal of used

appliance helps prevent potential negative consequences for the environment and human health.

Compliance with RoHS Directive

The product you have purchased complies with EU RoHS Directive (2011/65/EU). It does not contain harmful and prohibited materials specified in the Directive.



Package information

Packaging materials of the product are manufactured from recyclable materials in accordance with our National Environment Regulations. Do not dispose of the packaging materials together with the domestic or other wastes. Take them to the packaging material collection points designated by the local authorities.

CE Conformity with standards and test information / Declaration of EC conformity

Development, manufacture and sales stages of this product conform to the safety rules in all relevant guidelines of the European Community. 2014/35/EU, 2014/30/EU, 93/68/EC, IEC 60436/DIN 44990, EN 50242

3 Your Refrigerator

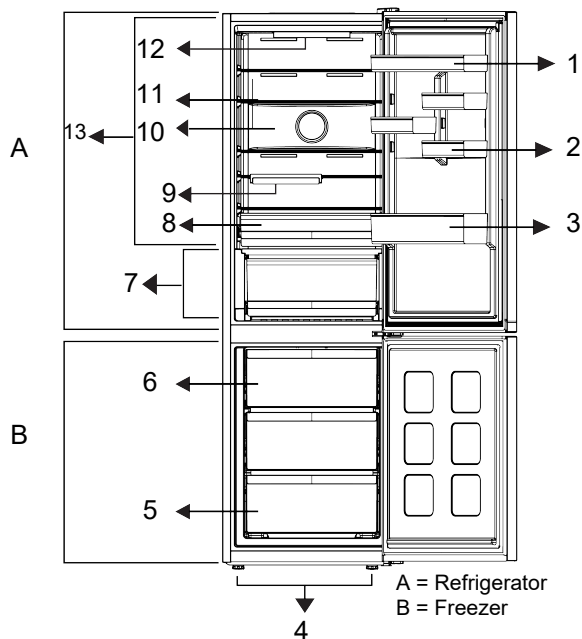

- | | |
|-----------------------------------|-------------------------|
| 1 Adjustable Door Shelf | 2 *Egg Rack |
| 3 * Bottle Rack | 4 * Adjustable Legs |
| 5 * Freezer Compartment | 6 * Ice Tray |
| 7 * Fresh Food / Vegetable Drawer | 8 * Cold Storage Drawer |
| 9 *Foldable Bottle Rack | 10 * Fan |
| 11 *Adjustable Trunk Shelf | 12 *Lighting Lamp |
| 13 * Cold Compartment | |

***Optional** The figures in this user manual are schematic and may not be exactly compatible with your product. If the product you purchased does not contain the relevant parts, they are valid for other models.

4 Installation

Read the "Safety Instructions" first!

4.1 Right Place For Installation

Contact the Authorized Service for the product's installation. To prepare the product for installation, see the information in the user manual and make sure the electric and water utilities are as required. If not, call an electrician and plumber to arrange the utilities as necessary.

- Place the product on a flat surface to avoid vibration
- Place the product at least 30 cm away from the heater, stove and similar sources of heat and at least 5 cm away from electric ovens.
- When placing two coolers in adjacent position, leave at least 4 cm distance between the two units.
- Keep the product out of direct sunlight and in a dry place.
- Products need to have at least 5cm clearance between side walls and rear wall to reach the declared performance values.

If clearance is less than 5cm, energy and performance losses will be at a level that will not affect to end user.

4.2 Adjusting the Legs

If the product is not in balanced position, adjust the front adjustable legs by rotating them to right or left.

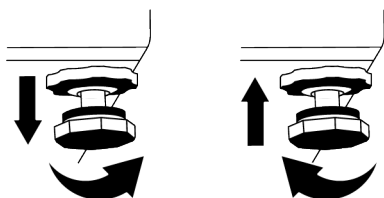

4.3 Hot Surface Warning

The side walls of your product are equipped with cooler pipes to enhance the cooling system. High pressure fluid may flow through these surfaces, and cause hot surfaces on the side walls. This is normal and it does not require servicing.

5 Preparation

Read the "Safety Instructions" first!

5.1 What To Do For Energy Saving

- This refrigerating appliance is not intended to be used as a built in appliance.
- When loading the food, leave enough space inside the refrigerator to allow sufficient air circulation for cooling.
- Since hot and humid air will not directly penetrate into your product when the doors are not opened, your product will optimize itself in conditions sufficient to protect your food. Under these circumstances, functions and components such as compressor, fan, heater, defrost, lighting, display and so on will operate according to the needs by consuming minimum energy.
- In case that multiple options are present, glass shelves must be placed so that the air outlets at the rear wall are not blocked and preferably, in a way that air outlets remain below the glass shelf. This combination may help improving air distribution and energy efficiency.
- Using the below drawer when storing is strongly recommended.
- For optimum performance, Quick Freezing can be used (if available), 24 hours prior to placing fresh foods in the freezer.

- In most cases, 24 hours is enough for the Quick Freezing function after fresh foods are placed in the freezer. After some time, Quick Freezing function will deactivate automatically.
- When freezing a small amount of food, Quick Freezing function can be deactivated after some time to ensure energy saving.
- Depending on the product's features; defrosting frozen foods in the refrigerator compartment will ensure energy saving and preserve food quality.
- In order to load the maximum quantity of food into the freezer compartment of your appliance, the upper drawers should be taken out and the food should be placed onto the wire/glass shelves.
- Place the food as shown below, keeping a distance from the refrigerator temperature sensor. If they are in contact with the sensor, energy consumption of the appliance might increase.

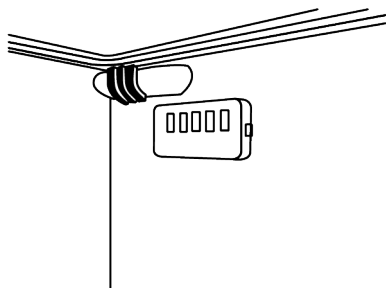

- Store food in refrigerator according to proper storage conditions to save energy.
- Food packages shall not be in direct contact with the temperature sensor located in the freezer compartment.

5.2 First Use

Before using your product make sure the necessary preparations are made in line with the instructions in "Safety Instructions" and "Installation" sections.

- Wait for at least 2 hours before operating the product, to ensure the complete efficiency of refrigeration.
- Keep the product running without placing any food inside for 6 hours and the product door should be kept as closed as possible.
- The temperature change caused by opening and closing of the door while using the product may normally lead to condensation on door/body shelves and glassware placed in the product.
- A sound will be heard when the compressor is engaged. It is normal for the product to make noise even if the compressor is not running, as fluid and gas may be compressed in the cooling system.
- It is normal for the front edges of the product to be warm. These areas are designed to warm up in order to prevent condensation
- For some models, indicator panel turns off automatically 1 minute after the door closes. It will be reactivated when the door is opened or any button is pressed.

5.3 Climate Class and Definitions

Please refer to the Climate Class on the rating plate of your device. One of the following information is applicable to your device according to the Climate Class.

- **SN:** Extended Temperate Climate: This cooling device is designed for use at ambient temperatures between 10 °C and 32 °C.
- **N:** Temperate Climate: This cooling device is designed for use at ambient temperatures between 16°C and 32 °C.
- **ST:** Subtropical Climate: This cooling device is designed for use at ambient temperatures between 16°C and 38°C.
- **T:** Tropical Climate: This cooling device is designed for use at ambient temperatures between 16°C and 43°C.

6 Operating the Product

Read the "Safety Instructions" first!

- The product should only be used for food storage.
- If you will be away from home for an extended period (e.g., on vacation) and will not be using the ice maker or water dispenser, turn off the water valve. Otherwise, a water leak may occur.
- Slight variations in surface brightness may be observed on stainless steel surfaces due to the manufacturing process

and the inherent characteristics of the material. This is normal and does not affect product performance.

Product shutdown

- Remove the food to prevent odors.
- Wait for the ice to melt, clean the interior, and let it dry, leaving the doors open to avoid damaging the interior plastics.

7.1 Control Panel of the Product

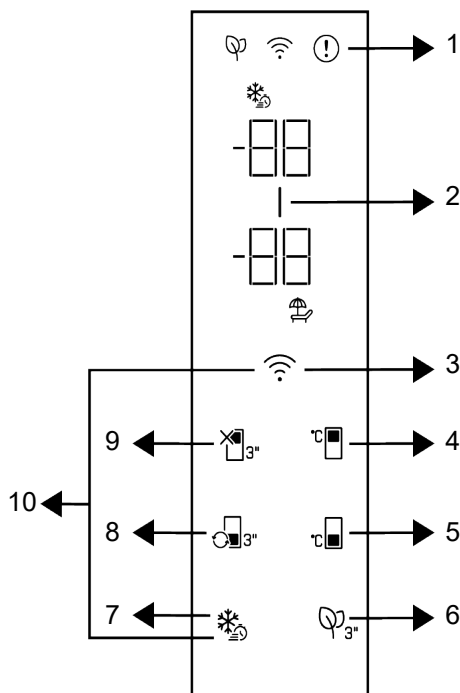

1 * Error Status Indicator

3 *Wireless Key

5 * Freezer Compartment Temperature Setting Key

7 * Quick Freezing Key

9 * Cooler Compartment OFF (Vacation) Function

2 * Energy Saving (Display Off) Indicator

4 * Cooler Compartment Temperature Setting Key

6 * Deodoriser Module Key

8 *Compartment Conversion Key

10 *Key for Resetting Wireless Connection Settings

Read the "Safety Instructions" first!

Auditory and visual functions on the indicator panel will assist you when using the product.

***Optional:** Shown functions are optional, there may be differences of shape and location in functions found on your appliance's indicator panel.

1. Error Condition Indicator

This indicator shall be active when your refrigerator cannot perform adequate cooling or in case of any sensor error. "E" will be displayed on the freezer compartment temperature indicator and figures such as 1,2,3... will be displayed on the cooler compartment temperature indicator. These fig-

ures on the indicator provide information to the authorized service about the error that has occurred. Exclamation mark may be displayed when you load warm food to the freezer compartment or keep the door open for a long period of time. This is not a fault, this warning shall be removed when the food is cooled down or when any key is pressed.

2. Energy Saving (Display Off) Indicator

Energy saving function is enabled automatically and the energy saving symbol lights up when the door of the product is not opened or closed for some period of time. When the energy saving function is active, all symbols on the display except the energy saving symbol shall be turned off. When the energy saving function is active, pressing any key or opening the door will deactivate the energy saving function and the display signals will return to normal. The energy saving function is a function activated ex-factory and cannot be cancelled.

3.*Wireless Key

This key is utilized to connect wirelessly to your appliance through HomeWhiz mobile application. If the key is pressed for a long time (3 seconds), the wireless connection symbol on the display/indicator will blink slowly (in 0.5 second intervals). The home network is initialized on the product this way. After achieving wireless connection with the product, wireless connection symbol illuminates continuously. You may activate/deactivate the connection after the first setting is completed by pressing this key. The wireless connection symbol will flash quickly (at 0.2 second intervals) until the connection is established. When the connection becomes active, wireless connection symbol flashes continuously. If the connection cannot be established for a long period, check your connection settings and refer to the "Troubleshooting" section provided in the user manual. Use HomeWhiz application for wireless connection. The installation steps are described on the application during installation. You may ac-

cess the application by reading the QR code available on the HomeWhiz label on the product. The application can be obtained from App Store for IOS devices or from Play Store for Android devices. For details visit <https://www.homewhiz.com/> address.

4. Cooler Compartment Temperature

Setting Key

Allows setting of temperature for cooler compartment. Pressing the key will enable the cooler compartment temperature to be set at 8 °C, 7 °C, 6 °C, 5 °C, 4 °C, 3 °C, 2 °C, and 1 °C.

5.Freezer Compartment Temperature

Setting Key

Temperature setting is made for freezer compartment. Pressing the key will enable the freezer compartment temperature to be set at -18 °C, 19°C, -20 °C, -21 °C, -22 °C, -23 °C, and -24 °C.

6.*Deodoriser Module Key

Press this key for 3 seconds to activate/deactivate the deodoriser feature. When the deodoriser feature is active, the deodoriser module icon is illuminated. When the feature is active, the deodoriser module will be operated periodically.

7.*Quick Freezing Key

When the quick freezing key is pressed the quick freezing symbol shall be illuminated and the quick freezing function shall be activated. The freezer compartment temperature is set to -27 °C. Press the key again to cancel the function. The quick freezing function will be cancelled automatically. To freeze a large amount of fresh food, press the quick freezing key before placing the food in the freezer compartment.

8.*Compartment Conversion Key

When the compartment conversion key is pressed for 3 seconds, the freezer compartment switches between fresh food, off and freezer modes, respectively. When it is operated as fresh food compartment, the

compartment temperature is set as 4 °C. In OFF mode, compartment temperature indicator shall display "--".

9.*Cooler Compartment Off (Vacation)

Function Key

Press the key for 3 seconds to activate the vacation function. Vacation mode is activated and the vacation symbol is illuminated. "--" expression is displayed on the cooler compartment temperature indicator and the cooler compartment does not perform active cooling operation. It is not suitable to keep your food in the cooler compartment when this function is activated. The other compartments continue to cool according to temperatures set before. Press the key for 3 seconds again to cancel this function.

10.*Key for Resetting Wireless Connection Settings +

To reset wireless connection settings, Quick freezing and Wireless connection keys should be pressed simultaneously for 3 seconds. All user information recorded previously are removed on the product where wireless connection settings are reset/restored to factory defaults.

7.1.1 High Temperature Alarm

The refrigerator's display blinks '- -' set values and sounds an alarm if the freezer compartment is too warm. This might occur if the freezer's temperature rises due to a power failure. The highest temperature in the freezer compartment is displayed until any button is pressed. "If the display has an electronic screen, the maximum actual temperature reached is displayed." If not, only '- -' blinks, and sounds are activated. To deactivate the alarm, press any display button.

7.2 Food Storage in Refrigerator

Food Storage in Refrigerators and Cold Compartments

- Frequent opening and closing of the compartment door, or leaving it open for extended periods, can cause compartment temperatures to rise significantly, reducing food shelf life and leading to spoilage.
- To prevent changes in smell and taste, food should be stored in airtight containers.
- To achieve better and more even cooling, place the food items far apart so that cold air can circulate between them.
- Allow for airflow by leaving a gap between the food and the inside wall. If you place the food against the back wall, it may freeze.
- Allow cooked, hot food to cool to room temperature before refrigerating. Then, you can place the lukewarm food on the lower shelves of your refrigerator. Keep lukewarm food away from perishable foods.
- Pay particular attention to ensuring that frozen foods are not mixed with fresh foods.
- Thaw your frozen foods in the refrigerator. This way, you can use the frozen food to cool the compartment, saving energy.
- Storing unripe tropical fruits (mangoes, various types of melons, papayas, bananas, pineapples) in the refrigerator can accelerate the ripening process. This means a shorter storage time, so it is not recommended.
- Onions, garlic, ginger, and other root vegetables should be stored in a dark, cool room, not in the refrigerator.
- If you notice that food in your refrigerator has spoiled, discard it and clean any accessories that came into contact with it.
- To quickly cool down large pot dishes like soups and stews, you can divide them into shallow containers and store them in the refrigerator.
- Keep unpackaged foods away from eggs.

- Keep fruits and vegetables separate and store all types together (for example, apples with apples, carrots with carrots).
- Remove the greens from the plastic bag, wrap them in paper towels or a dishcloth, and place them in the refrigerator. If you wash these types of foods before putting them in the refrigerator, remember to dry them.
- You can create a moist environment while allowing air circulation by storing fruits and vegetables that are prone to drying out in perforated or open-mouthed plastic bags.
- Except in cases of extreme environmental conditions, food in all compartments will stay fresh longer if your product is set to the set values indicated in the recommended set value table.
- Do not store cold-sensitive vegetables such as leafy greens, tomatoes, and cucumbers in the cold compartment.

Storage in the Cold Compartment Food

In the cold storage area, the temperature of the food being stored can vary between +3°C and -3°C. Temperatures may drop below 0°C in the cold storage area, therefore it is not suitable for storing fresh fruits/vegetables.

Store foods in different places according to their characteristics:	
Food	Location
Egg	Door shelf
Dairy products (butter, cheese)	If available, zero degree (breakfast) compartment / cold zone
Fruits, vegetables and fresh food	Fresh food compartment, vegetable drawer.
Fresh meat, poultry, fish, sausage products, cooked foods.	If available, zero degree (breakfast) compartment / cold zone
Ready-to-eat foods, packaged products, canned goods, and pickles.	Top shelves or door shelf
Beverages, bottles, condiments, and snacks.	Door shelf

Storage in Freezer Compartment Food

- You can activate the Quick Freeze function 4-6 hours before freezing to make it chilling even more effective.
- Allow hot food to reach room temperature before placing it in the freezer compartment.
- Foods to be frozen should be divided into portions large enough for each serving and frozen in separate packages.
- It is recommended to package food before placing it in the freezer.
- To prevent food from going past its expiration date, write the freezing date, storage time, and name of the food on the package according to the storage times of different foods.
- Consume thawed food quickly. Thawed food cannot be refrozen unless cooked. It is not safe to consume thawed and refrozen fresh food without cooking it.
- When freezing fresh food, do not allow these foods to come into contact with already frozen foods. Otherwise, the frozen foods will thaw.

Storing Frozen Foods

- When storing Food, please observe the time periods specified in these instructions.
- To preserve food quality, try to keep the time between purchase and storage as short as possible.
- Buy frozen foods that are stored at -18°C or lower.
- Avoid buying foods that have ice or similar substances in their packaging. This means the product may have partially thawed and then refrozen. Temperature affects the quality of the food.
- Store food for the time recommended by the manufacturer. Only take out as much as you need from the freezer.

- Except in cases of extreme environmental conditions, if your product is set to the set values specified in the recommended set value table, food will stay fresh longer in both the fresh food compartment and the freezer compartment.
- Fresh fruits and vegetables may partially freeze if the Fresh food compartment is set to a lower temperature.
- The 2-star compartment is suitable for pre-frozen food. Ice cream and ice cubes can be stored there.
- Freeze food only in the 4-star compartment.

Meat and Fish		Preparation Method	Longest storage period (month)	
Meat Products	Veal	Steak	Cut into 2 cm thick pieces and place foil between them or wrap tightly with plastic wrap.	6-8
		Roast	By packaging the meat pieces in a freezer bag or wrapping them tightly with plastic wrap.	6-8
		Flaked	In small pieces	6-8
		Schnitzel, chops	By placing foil between the sliced pieces or wrapping them individually with plastic wrap.	6-8
	Mutton	Chop	By placing foil between the pieces of meat or wrapping them individually with plastic wrap.	4-8
		Roast	By packaging the meat pieces in a freezer bag or wrapping them tightly with plastic wrap.	4-8
		Flaked	By packaging the chopped meat in a freezer bag or wrapping it tightly with plastic wrap.	4-8
	Beef	Roast	By packaging the meat pieces in a freezer bag or wrapping them tightly with plastic wrap.	8-12
		Steak	Cut into 2 cm thick pieces and place foil between them or wrap tightly with plastic wrap.	8-12
		Flaked	In small pieces	8-12
		Boiled meat	By packaging it in small portions using freezer bags.	8-12
	Mince	Unseasoned, in flat packs.	1-3	
	Offal (part)	In pieces	1-3	
	Sausage - Salami	Even if it's in a plastic bag, it must be packaged.	1-3	
Ham	By placing foil between the sliced pieces.	2-3		
Poultry and game animals	Chicken and Turkey	Wrapped in foil	4-6	
	Goose	Wrap in foil (portions should not exceed 2.5 kg)	4-6	
	Duck	Wrap in foil (portions should not exceed 2.5 kg)	4-6	
	Deer, Rabbit, Roe Deer	Wrap in foil (portions should not exceed 2.5 kg, and the bones should be removed).	6-8	
Fish and seafood	Freshwater fish (Trout, Carp, Pike, Catfish)	After thoroughly cleaning the insides and scales, it should be washed and dried, and the tail and head should be cut off if necessary.	2	
	Lean fish (Sea bass, Turbot, Sole)		4-6	
	Oily fish (Bonito, Mackerel, Bluefish, Red Mullet, Anchovy)		2-4	
	shellfish		Cleaned and in bags.	4-6
	Caviar		In its packaging, in an aluminum or plastic container.	2-3

"The storage times indicated in the table are based on a storage temperature of -18°C."

Vegetables and Fruits	Preparation Method	Longest storage period (month)
Pole beans	After washing and cutting into small pieces, blanch for 3 minutes.	10-13
Pea	After cleaning and washing, blanch for 2 minutes.	10-12
Cabbage	After cleaning, blanch for 1-2 minutes.	6-8
Carrot	After cleaning and slicing, blanch for 3-4 minutes.	12
Pepper	After cutting off the stem, splitting it in half and removing the seeds, blanch it for 2-3 minutes.	8-10
Spinach	After washing and cleaning, blanch for 2 minutes.	6-9
Leek	After chopping, blanch for 5 minutes.	6-8
Cauliflower	Separate the leaves, cut the center into pieces, and then blanch it in a little lemon water for 3-5 minutes.	10-12
Aubergine	After washing, cut into 2cm pieces and blanch for 4 minutes.	10-12
Courgette	After washing, cut into 2cm pieces and blanch for 2-3 minutes.	8-10
Mushroom	Lightly sauté in oil and squeeze lemon over it.	2-3
Sweetcorn	Clean and pack with the cork or as grainy	12
Apples and Pears	Peel the skin, slice it, and blanch it for 2-3 minutes.	8-10
Apricots and peaches	Cut it in half and remove the seeds.	4-6
Strawberries and Raspberries	By washing and sorting	8-12
cooked fruit	By adding 10% sugar in the container	12
Plum, Cherry, Sour Cherry	After washing and removing the stems	8-12

"The storage times indicated in the table are based on a storage temperature of -18°C."

Dairy products	Preparation Method	Longest Storage Period (Months)	Storage Conditions
Cheese (excluding feta cheese)	In slices, with foil placed in between.	6-8	For short-term storage, it can be left in the original package. For long-term storage, it should also be wrapped in aluminum or plastic foil.
Butter, margarine	In its own packaging	6	In its original packaging or plastic containers

"The storage times indicated in the table are based on a storage temperature of -18°C."

"The amount of fresh food that can be frozen within a specific time period is indicated on the type label."

Freezer Compartment Setting	Cooler Compartment Setting	Remarks
-22°C	2°C	This is the default, recommended setting. This setting is recommended if ambient temperature is below 30°C.

Freezer Information

According to IEC 62552 standards, for every 100 litres of freezer volume compartment, the product must be able to freeze 4.5 kg of substance food at 25°C room temperature for 24 hours at -18°C or lower. Long-term preservation of Food substances is only possible at temperatures of -18°C and lower.

You can keep the Food ingredients fresh for months (in a deep freezer at -18°C and lower temperatures).

Items to be frozen should not be brought into contact with previously frozen foods in order to prevent partial thawing.

To extend the storage time of frozen vegetables, blanch them and drain the water.

After draining, place them in airtight containers and put them in the freezer. Foods such as bananas, tomatoes, lettuce, celery, boiled eggs, potatoes, etc., are not suitable for freezing. If these foods are frozen, only their nutritional value and eating quality will be negatively affected. There is no risk of spoilage that threatens human health.

Food Placement

Freezer shelves compartment: Various frozen foods such as meat, fish, ice cream, vegetables, etc.

Chiller Compartment shelves: Food in pots, covered dishes and covered containers, eggs (in a covered container)

Chiller Compartment door shelves: Small and packaged food or drinks

Crisper: Vegetables and fruits

Fresh food compartment: Deli products (breakfast items, meat products to be consumed quickly)

7.3 Crispers/Fresh food compartment

The vegetable drawer of the product is specifically designed to keep vegetables fresh without losing moisture. For this purpose, cold air circulation is concentrated throughout the vegetable drawer. Store your veget-

ables and fruits in this compartment. To ensure longer storage, do not place leafy green vegetables next to fruits.

7.4 Crisper Technologies

VitalCare

Fruits and vegetables stored in vegetable drawers illuminated with VitalCare technology retain their antioxidant values for longer thanks to blue, green, and red lights and dark cycles that simulate the day cycle. With this innovative technology, we not only use the power of colors to preserve food quality but also transform it into a visual experience. Each time the door of your product is opened, the vegetable drawer will be illuminated with Red, Yellow, Green, Purple, or Orange colors in sequence, providing both easy visibility in the dark and a vibrant and dynamic visual experience for the user. The dark period will continue when you close your product, representing the night period in the day cycle.

7.5 Dairy Products Cold Storage Area

Cold Storage Compartment

The Cold Storage Compartment provides a lower temperature inside the product. Use this compartment to store deli products (salami, sausages, dairy products, etc.) or meat, chicken, and fish products that need to be kept at a lower temperature for immediate consumption. Do not store fruits and vegetables in this compartment.

7.6 Reversing the Door Opening Side

The door opening side of your refrigerator can be reversed according to the place you put it. For the products that include electrical display when you need this, you should definitely call the nearest Authorized Service.

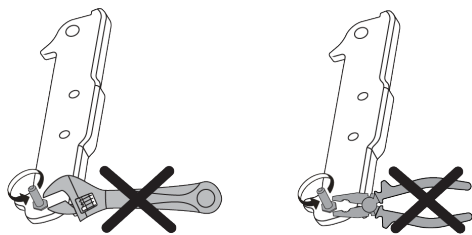

7.7 Door Open Alert

The door open alert system of your refrigerator may differ depending on the model.

Version 1;

If the door of the product remains open for a certain time (between 60 s and 120 s), an audio warning signal sounds; depending on the product model, a visual warning signal (light flash) can also be displayed. If you close the door of the device or press a button on the screen of the device, if any, the warning sound will stop.

Version 2;

If the door of the device remains open for a certain period of time (between 60 s and 120 s), the door open alert is sounded. The door open alert is sounded gradually. First, an audible warning starts to sound. After 4 minutes, if the door is still not closed, a visual warning (lighting flash) is activated. The door open alert will be delayed for a certain period of time (between 60 s and 120 s) when any key on the product screen, if any, is pressed. Then the process will start again. When the device door is closed, the door open alert will be cancelled.

7.8 Replacing the Illumination Lamp

Call the Authorized Service when the Bulb/LED used for lighting in your refrigerator will be replaced.

Lamp(s) used in this appliance cannot be used for house lighting. Intended use of this lamp is to help the user place food into the refrigerator / freezer safely and comfortably.

This product contains a lighting source with 'G' energy class.

The lighting source in this product must be replaced by a qualified repair person.

7.9 Active Check

Active Check is a smart control feature that constantly monitors your product's status using artificial intelligence, identifying potential problems before they even occur and notifying you. This ensures your product's performance is always secure and prevents unexpected malfunctions. For Active Check to work, your product must be connected to the internet via the HomeWhiz app.

7.10 Artificial Intelligence (AI) Technology



Artificial Intelligence Feature

Your product features Artificial Intelligence. For this feature to work, your product must be added to the HomeWhiz app and connected to the internet.

In the HomeWhiz app, you can turn the AI feature on or off from the helper functions page for your specific product.

Thanks to its autonomous technology, your product adapts to your usage habits and offers high energy efficiency. * It provides savings of up to 20%.

* The stated savings figures are obtained under standard laboratory conditions. Your savings figures may vary depending on customer usage conditions and climate.

7.11 Energy Management

Your product has an energy consumption management feature. For this feature to work, your product must be added to the HomeWhiz application and connected to the internet.

You can track your appliance's consumption information using the HomeWhiz Energy Management panel.

You can view the consumption information of your smart product according to different time periods. * You can monitor it and save money by following suggestions to reduce your consumption.

* The consumption values stated on the product label are obtained under standard laboratory conditions. The consumption values shown in the HomeWhiz app are for informational purposes only and may differ from actual consumption values depending on customer usage conditions and climate.

7.12 Using the Water Dispenser

- The first few glasses of water taken from the fountain will normally be warm.
 - If you have not used the water dispenser for a long time, dispose of the first few glasses of water to get clean water.
1. Press on the arm of the water dispenser with your glass. It would be easier to press on the arm with your hand if you are using a soft plastic glass.
 2. Release the arm after filling your glass with water as you desire.

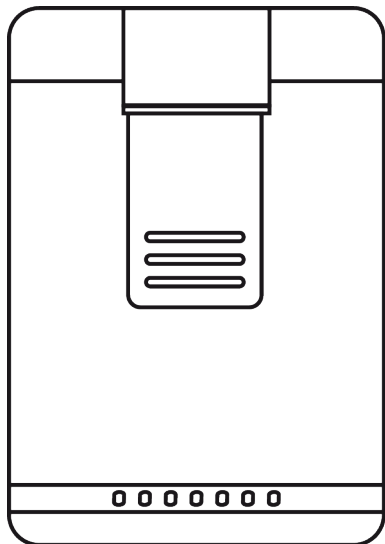

- The amount of water flow from the fountain depends on the pressure you apply on the arm. Release the pressure on the arm slightly as the water level in your glass/container is increased to prevent overflow. Water shall drip if you press the arm slightly; this is normal and it is not a malfunction.

Filling the water tank of the water dispenser

1. Open the lid of the water tank as shown in the figure. Fill in pure and clean drinking water. Close the lid.

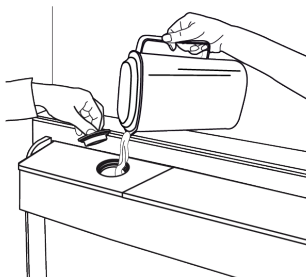

- Water reservoir capacity is 3 litres, do not overfill.

Cleaning the water tank

1. Remove the water filling reservoir inside the door shelf.

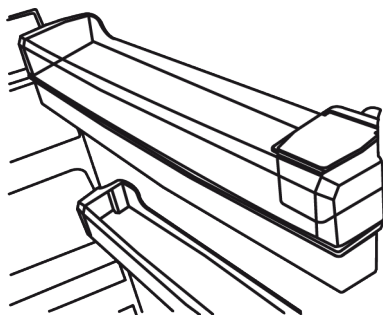

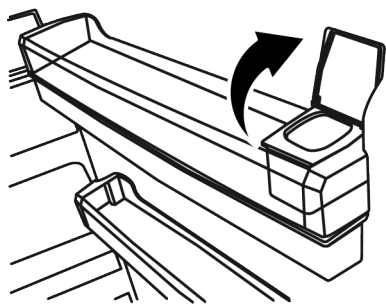

1. Detach by holding both sides of the door shelf.

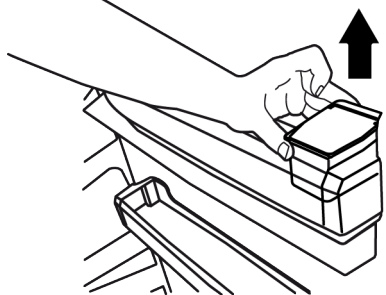

2. Hold both sides of the water tank and remove at 45° angle.

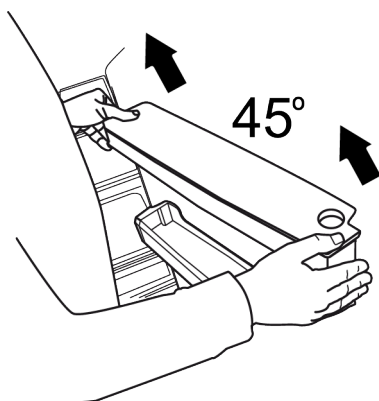
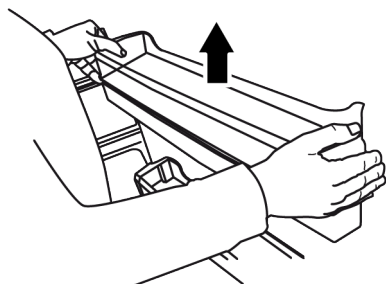

3. Remove and clean the water tank lid.

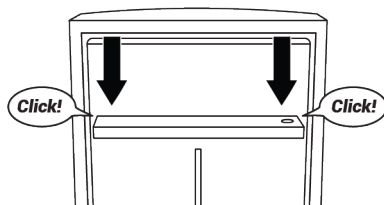
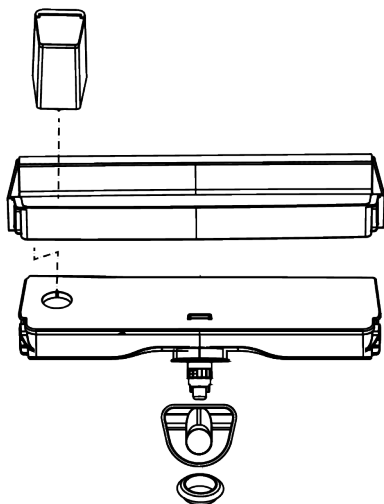

- Do not fill the water tank with fruit juice, fizzy beverages, alcoholic beverages or any other liquids incompatible for use in the water dispenser. Using such liquids will cause malfunction and irreparable damage in the water dispenser. Using the fountain in this way is not within the scope of warranty. Certain chemicals and additives in such beverages / liquids may cause material damage to the water tank.

- Use clean drinking water only.
- Do not wash the components of the water tank and water dispenser in the dishwasher.

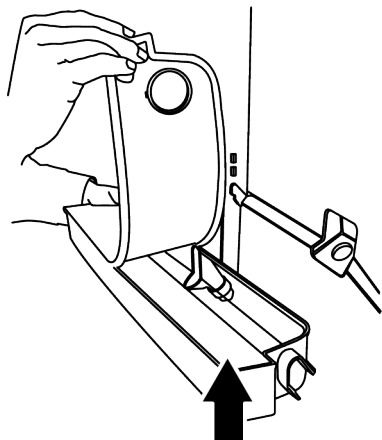

- Before using the water dispenser in the product, check whether the Child Lock is active or not. Refer to the information in the figures about the Child lock ON/OFF positions to check.. Make sure that the Child lock exactly closes as in the figure when it is turned OFF.

Child lock is on like this.

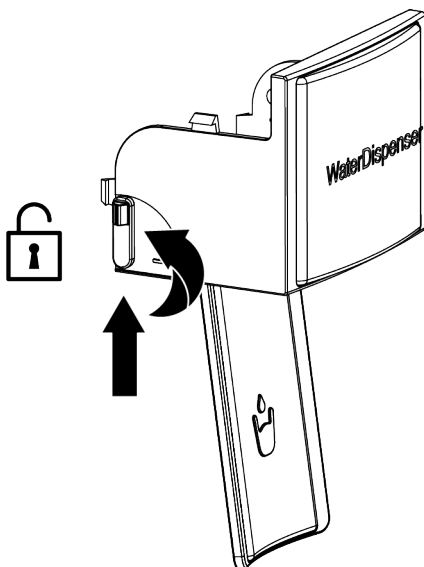

Child lock is off like this.

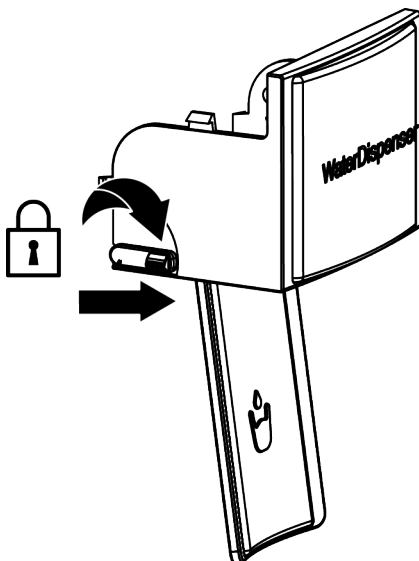

8 Maintenance and Cleaning

Read the "Safety Instructions" first!

- Unplug your appliance before cleaning it.

- The dust on the ventilation grille on the back of the product should be removed (without opening the lid) at least once a year. Cleaning should be done with a dry cloth.

For products that include a water dispenser/ice machine.

- If the water in the tank has been left standing for 2-3 weeks, it should be changed.
- The water tank and water dispenser parts should not be washed in a dishwasher.
- Dissolve one teaspoon of baking soda in half a liter of water. Wet a cloth with this solution and wring it out thoroughly. Wipe the inside of your appliance with this cloth and then dry it completely.
- Ensure that water does not enter the lamp housing, LED light lens, ventilation holes, and other electrical parts. Risk of electric shock and short circuit!
- Do not open or perform cleaning, maintenance, or repair work on electrical components (control board cover, compressor rear cover (if applicable) without authorization. If your product does not have a cover on the compressor area, absolutely do not touch this area or use any tools to come into contact with it. Risk of electric shock and injury!
- Clean the door with a damp cloth. Remove all contents from your product, including the door and body shelves. Lift the door shelves upwards to remove them. After cleaning and drying, slide the shelves back into place from top to bottom.
- Never use chlorine-containing water or cleaning agents for cleaning the exterior surface of the product or chrome-plated parts. Chlorine causes rust on these types of metal surfaces.
- For any reason, do not put your hands, feet, or any metal objects under or between the product. Pinch or any sharp edges could cause personal injury.
- To prevent the prints on the plastic part from peeling off or deforming, do not use sharp, abrasive tools, soap, household cleaning products, detergents, gasoline, polish, etc. For cleaning, use a soft cloth with lukewarm water and dry.
- Water droplets and up to a finger's thickness of frost will form on the back wall of the cooler compartment. Do not clean it, and absolutely do not apply oil or similar substances.
- Use only a slightly damp microfiber cloth for cleaning the exterior surface of the product. Sponges and other types of cleaning cloths may cause scratches.
- To clean the interior surfaces of the product, wash all removable parts with a mild solution of soap, water, and baking soda. Rinse thoroughly and dry completely. Prevent water from getting into the lights and control panel.
- Be careful not to let water get into the lamp housing and other electrical parts.
- Clean the door with a damp cloth. Remove all contents to take out the door and body shelves. Lift the door shelves upwards to remove them. After cleaning and drying, slide them back in place from top to bottom.
- Never use chlorine-containing water or cleaning agents for cleaning the exterior surface of the product or chrome-plated parts. Chlorine causes rust on these types of metal surfaces.
- To prevent the prints on the plastic part from peeling off or deforming, do not use sharp, abrasive tools, soap, household cleaning products, detergents, gasoline, polish, etc. For cleaning, use a soft cloth with lukewarm water and dry.
- In products without No Frost technology; water droplets and up to a finger's thickness of frost will form on the back wall of the cooling compartment. Do not clean it, and absolutely do not apply oil or similar substances.
- Use only a slightly damp microfiber cloth for cleaning the exterior surface of the product. Sponges and other types of cleaning cloths may cause scratches.
- To clean the interior surfaces of the product, wash all removable parts with a mild solution of soap, water, and baking

For products without No Frost;

soda. Rinse thoroughly and dry completely. Prevent water from getting into the lights and control panel.

- Do not use vinegar, rubbing alcohol, or other alcohol-based cleaners on any interior surfaces.

Stainless Steel Exterior Surfaces

Use a non-abrasive stainless steel cleaner and apply it with a lint-free, soft cloth. To polish, gently wipe the surface with a microfiber cloth dampened with water and use a dry polishing pad. Always follow the grain of the stainless steel.

9 Troubleshooting

Read the "Safety Instructions" first!

If you are unable to resolve the problem even after following the instructions in this section, contact the retailer or authorized service center where you purchased the product. Never attempt to repair the malfunctioning product yourself.

The refrigerator does not work.

- The plug is not fully seated in the socket. >>> Insert the plug so that it is fully seated in the socket.
- The fuse in the outlet the product is plugged into, or the main fuse, has blown. >>> Check the fuse.

Condensation on the side wall of the refrigerator compartment.

- The door has been opened and closed too frequently. >>> Please be careful not to open and close the product's door too often.
- The environment is very humid. >>> Do not install the product in very humid environments.
- Foods containing liquids may be stored in open containers. >>> Store foods containing liquids in closed containers.
- The product door was left open. >>> Do not leave the product door open for a long time.

Preventing Bad Odors

No substances that could cause odor are used in the production of your product. However, odors may arise due to improper food storage and failure to properly clean the product's interior surface.

- To prevent this problem, clean with baking soda water every 15 days.
- Store food in sealed containers, as microorganisms released from open food can cause bad odors.
- Never store expired or spoiled food in your product.

Protection of Plastic Surfaces

If oil spills on plastic surfaces, clean them immediately with warm water, as the oil can damage the surface.

- The thermostat is set to too cold. >>> Adjust the thermostat to the appropriate setting.

The compressor is not working.

- In the event of a sudden power outage or when the plug is removed and reinserted, the compressor's protective thermal switch will trip because the gas pressure in the product's cooling system has not yet equalized. The product should start working again after approximately 6 minutes. If the product does not start working after this time, call for service.
- It is in the defrost cycle. >>> This is normal for a fully automatic defrosting product. The defrost cycle occurs periodically.
- The product is not plugged into the power outlet. >>> Please make sure the plug is plugged into the power outlet.
- The temperature settings are incorrect. >>> Select the appropriate temperature setting.
- The power has been cut off. >>> The product will continue to function normally once the power is restored.

The refrigerator's operating noise increases when it's running.

- The product's performance may vary depending on changes in ambient temperature. This is normal and not a malfunction.

The refrigerator is running too often or for too long.

- The new product may be larger than the old one. Larger products last longer.
- The room temperature may be high. >>> It is normal for it to operate for longer periods in hot environments.
- The product may have been recently plugged in or new food may have been added. >>> When the product is newly plugged in or new food is added, it takes longer to reach the set temperature. This is normal.
- The product may have recently been served with large quantities of hot food. >>> Do not serve hot food in this product.
- The doors have been opened frequently or left open for extended periods. >>> The warm air entering causes the product to operate longer. Do not open the doors too often.
- The refrigerator door may have been left ajar. >>> Check if the doors are completely closed.
- The product is set to a very low temperature. >>> Adjust the product's temperature to a higher setting and wait for it to reach that temperature.
- The refrigerator door seal may be dirty, worn, broken, or not properly seated. >>> Clean or replace the seal. A damaged/broken door seal will cause the appliance to run longer to maintain its current temperature.

The freezer temperature is too low, but the refrigerator temperature is adequate.

- The freezer compartment temperature is set to a very low value. >>> Adjust the freezer compartment temperature to a higher setting and check.

The refrigerator temperature is too low, but the freezer temperature is adequate.

- The refrigerator compartment temperature is set to a very low value. >>> Adjust the refrigerator compartment temperature to a higher setting and check.

Food stored in refrigerator drawers freezes.

- The refrigerator compartment temperature is set to a very low value. >>> Adjust the refrigerator compartment temperature to a higher value and check.

The temperature in the refrigerator or freezer is too high.

- The refrigerator compartment temperature may be set too high. The refrigerator compartment temperature setting affects the freezer compartment temperature. Try adjusting the refrigerator or freezer compartment temperature and wait until the temperature in either compartment reaches a satisfactory level.
- The doors have been opened frequently or left open for too long. >>> Don't open the doors too often.
- The door might be ajar. >>> Close the door completely.
- The product may have been recently plugged in or new food may have been added. >>> This is normal. When the product is newly plugged in or new food is added, it takes longer than usual to reach the set temperature.
- The product may have recently been served with large quantities of hot food. >>> Do not serve hot food in this product.

Shaking or noise.

- The floor is not level or stable. >>> If the product wobbles when moved slowly, adjust its feet to balance it. Also, make sure the floor is stable enough to support the product's weight.
- Items placed on the product may be causing noise. >>> Remove any items from the product.
- The product is making sounds such as liquid leaking or spraying.

- Due to the product's operating principles, liquid and gas flows occur. >>> This is normal and not a malfunction.

The product is making a wind noise.

- A fan is used to perform the cooling process of the product. This is normal and not a malfunction.

Condensation is forming on the inner walls of the product.

- Hot and humid weather increases icing and condensation. This is normal and not a malfunction.
- The doors have been opened frequently or left open for too long. >>> Don't open the doors too often, and close them if they are open.
- The door might be ajar. >>> Close the door completely.

Condensation is forming on the outside of the product or between the doors.

- The air may be humid, which is quite normal in humid weather. Condensation disappears when the humidity decreases.

The inside of the product smells bad.

- Regular cleaning has not been performed. >>> Regularly clean the inside of the product with a sponge, warm water, or baking soda solution.
- Some containers or packaging materials may have odors. >>> Use odor-free containers or packaging materials.
- The food items were placed in open containers. >>> Store food in closed containers. Microorganisms released from food stored in open containers can cause unpleasant odors.

- Remove any expired or spoiled food from the product.

The door won't close.

- Food packages might be preventing the door from closing. >>> Move any packages that are blocking the doors.
- The product may not stand completely upright on the ground. >>> Adjust the legs to balance the product.
- The floor is not level or stable. >>> Ensure the floor is level and stable enough to support the product.

The vegetable drawers are cramped.

- Food items may be touching the top of the drawer. >>> Organize the food in the drawer.

There is heat on the product surface.

- While your product is operating, you may experience high temperatures between the two doors, on the side panels, and in the rear grille area. This is normal and does not require any servicing.

The fan continues to run when the door is opened.

- The fan may continue to operate even when the freezer door is opened.

If you are unable to resolve the problem even after following the instructions in this section, contact the retailer or authorized service center where you purchased the product. Do not attempt to repair the malfunctioning product yourself. This is normal.

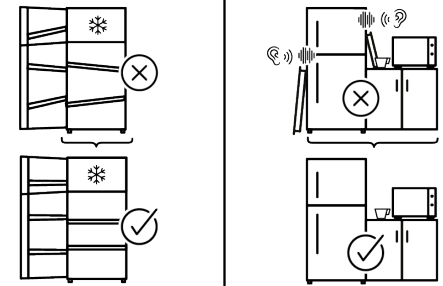
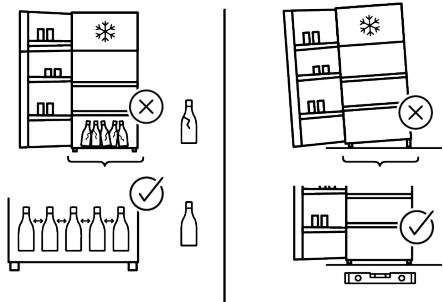
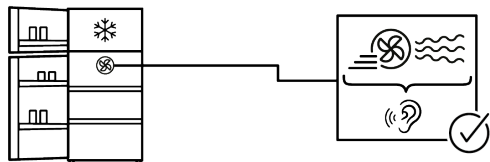
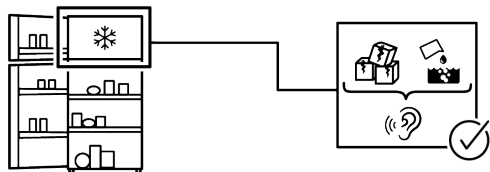
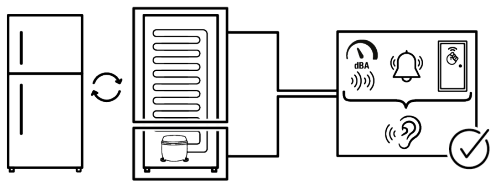

DISCLAIMER

Some (simple) failures can be adequately handled by the end-user without any safety issue or unsafe use arising, provided that they are carried out within the limits and in accordance with the following instructions (see the "Self-Repair" section).

Therefore, unless otherwise authorized in the "Self-Repair" section below, repairs shall be addressed to registered professional repairers in order to avoid safety issues. A registered Professional repairer is a professional repairer that has been granted access to the instructions and spare parts list of this product by the manufacturer according to the methods described in legislative acts pursuant to Directive 2009/125/EC.

However, only the service agent (i.e. authorized professional repairers) that you can reach through the phone number given in the user manual/warranty card or through your authorized dealer may provide service under the guarantee terms. Therefore, please be advised that repairs by professional repairers (who are not authorized by) Hotpoint shall void the guarantee.

Self-Repair

Self-repair can be done by the end-user with regard exclusively to the following spare parts: door handles, door hinges, trays, baskets and door gaskets (an updated list is also available parts-selfservice.europeanappliances.com as of 1st March 2021).

Moreover, to ensure product safety and to prevent risk of serious injury, the mentioned self-repair shall be done following the instructions in the user manual for selfrepair or which are available in parts-selfservice.europeanappliances.com. For your safety, unplug the product before attempting any self-repair.

Repair and repair attempts by end-users for parts not included in such list and/or not following the instructions in the user manuals for self-repair or which are available in

parts-selfservice.europeanappliances.com, might give rise to safety issues not attributable to Hotpoint, and will void the warranty of the product.

Therefore, it is highly recommended that end-users refrain from the attempt to carry out repairs falling outside the mentioned list of spare parts, contacting in such cases authorized professional repairers or registered professional repairers. On the contrary, such attempts by end-users may cause safety issues and damage the product and subsequently cause fire, flood, electrocution and serious personal injury to occur.

By way of example, but not limited to, the following repairs must be addressed to authorized professional repairers or registered professional repairers: compressor, cooling circuit, main board, inverter board, display board, etc.

The manufacturer/seller cannot be held liable in any case where end-users do not comply with the above.

The spare part availability of the refrigerator that you purchased is 10 years. During this period, original spare parts will be available to operate the refrigerator properly. The minimum duration of guarantee of the refrigerator that you purchased is 24 months.

This product is equipped with a lighting source of the "G" energy class.

The lighting source in this product shall only be replaced by Professional repairer.

