

# AKT 9020 B

12NC: 859991642420

GTIN (EAN) code: 8003437637315

Whirlpool

SENSING THE DIFFERENCE

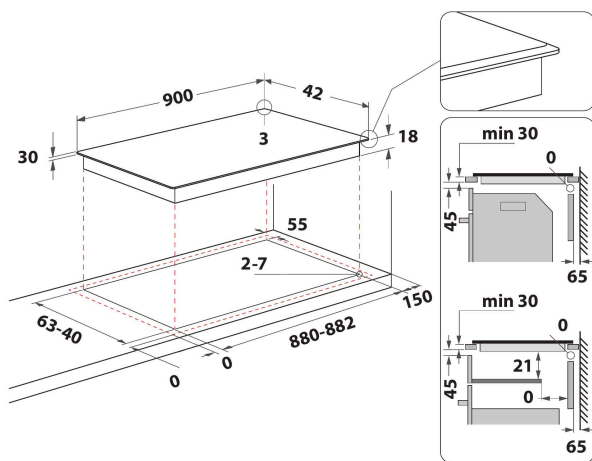
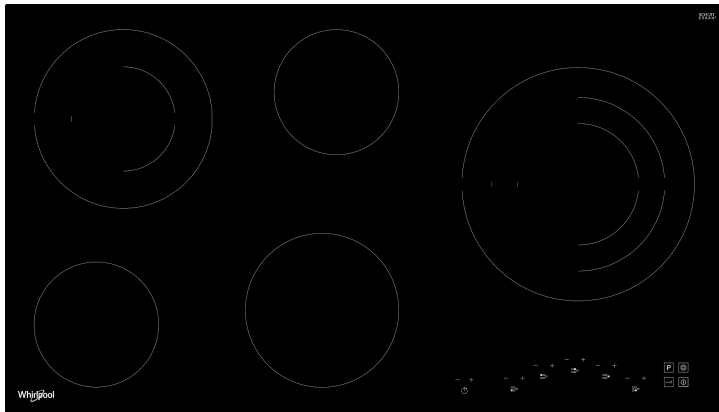

- Residual heat indicator
- Child lock
- On/Off Switch
- 90 cm hob
- Timer
- Black Glass Hob
- 5 Radiant cooking zones
- 5 Boosters
- 5 Plate on Indicator
- Power on indicator
- Supply cord included
- 5 Cooking zones: 1 Radiant 1200 W, 1 Radiant 700/2100 W, 1 Radiant 1200 W, 1 Radiant 1700 W, and 1 Radiant 900/1650/2400 W
- 1 side bevelled
- Dimensions HxWxD: 60x900x510 mm
- Electrical Connection Rating: 8600 W

## Whirlpool hob - AKT 9020 B

This Whirlpool Hob features: electric power supply.



### Touch control

Cooking at the press of a button. Thanks to TouchControl, the precise control of your hobs is at your finger tips. The sensor power regulation does without the 10 phases on most dials and thus allows for simpler cleaning and care for your hob.



### FRONT BEVELLED

The frontal part of the product is bevelled, providing a better integration with the countertop.



### Electronic Timer

Set the ideal time for your preparations based on the recipe's needs.



### Front Controls

Complete control over your cooking. Easily accessible and genuinely intuitive, the controls are conveniently positioned on the front panel of your hob, providing a frictionless cooking experience.



### Double zone G0

Versatile cooking experience. This Whirlpool Hob features the versatile Double Zone G0, providing 2 separate heat zones, so you can easily cook with both large and small pots and pans.

# AKT 9020 B

12NC: 859991642420

GTIN (EAN) code: 8003437637315

**Whirlpool**

SENSING THE DIFFERENCE

## MAIN FEATURES

Product group	Hob
Construction type	Built-in
Type of control	Electronic
Type of control settings	-
Number of gas burners	0
Number of electric cooking zones	5
Number of electric plates	0
Number of radiant plates	5
Number of halogen plates	0
Number of induction plates	0
Number of electric warming zones	0
Location of control panel	Front
Basic surface material	Ceramic Glass
Main colour of product	Black
Electrical connection rating (W)	8600
Gas connection rating (W)	0
Gas type	N/A
Current (A)	37,4
Voltage (V)	230/400
Frequency (Hz)	50/60
Length of Electrical Supply Cord (cm)	100
Plug type	No
Gas connection	N/A
Width of the product	900
Height of the product	60
Depth of the product	510
Minimum niche height	42
Minimum niche width	880
Niche depth	0
Net weight (kg)	11.9
Automatic programmes	No

## TECHNICAL FEATURES

Power on indicator	Yes
Number of indicators	5
Type of regulation	Stepless energy regulated
Type of lid	Without
Residual heat indicator	Separate
Main on/off switch	Yes
Safety device	-
Timer	Yes

## PERFORMANCES

Energy input	Electric
--------------	----------