

GMWL 728/IXL

12NC: 859991596220

GTIN (EAN) code: 8003437608568

Whirlpool

SENSING THE DIFFERENCE

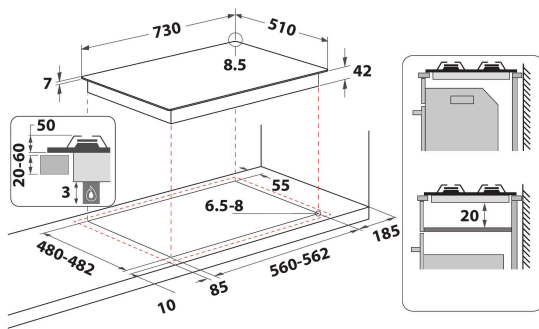

MAIN FEATURES

Product group	Ploča za kuhanje
Construction type	Ugradbeni
Type of control	-
Type of control settings	Knob
Number of gas burners	5
Number of electric cooking zones	0
Number of electric plates	0
Number of radiant plates	0
Number of halogen plates	0
Number of induction plates	0
Number of electric warming zones	0
Location of control panel	Front
Basic surface material	Inox
Main colour of product	Inox Ixelim
Electrical connection rating (W)	0
Gas connection rating (W)	11500
Gas type	G20
Current (A)	0,2
Voltage (V)	230
Frequency (Hz)	50
Length of Electrical Supply Cord (cm)	85
Plug type	Ne
Gas connection	Cilindric
Width of the product	730
Height of the product	41
Depth of the product	510
Minimum niche height	38
Minimum niche width	560
Niche depth	480
Net weight (kg)	13.2
Automatic programmes	Ne

TECHNICAL FEATURES

Power on indicator	Ne
Number of indicators	0
Type of regulation	Semirapid
Type of lid	Without
Residual heat indicator	Without
Main on/off switch	Ne
Safety device	-
Timer	Ne

ENERGY LABEL

Energy input

Gaz