

# WMN574BXA

12NC: 859991686640

GTIN (EAN) code: 8003437397721

**Whirlpool**

SENSING THE DIFFERENCE

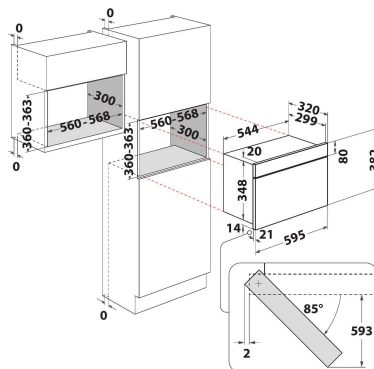
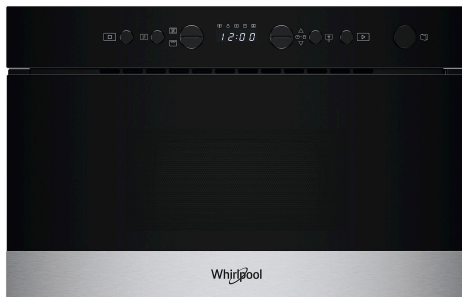

## MAIN FEATURES

Product group	Mikrovalna pečnica
Commercial code	WMN574BXA
Main colour of product	Stainless steel
Type of micro-wave oven	MW+Grill function
Construction type	Ugradbeni
Type of control	Electronic
Type of control settings	LED
Additional cooking method Grill	Yes
Funkcija Crisp	Yes
Steam	Ne
Additional cooking method Fan cooking	Ne
Clock	Yes
Automatic programmes	Ne
Height of the product	382
Width of the product	595
Depth of the product	320
Minimum niche height	360
Minimum niche width	556
Niche depth	300
Net weight (kg)	21
Ljubičasta sa bisernim odsjajem	22
Turntable	Yes
Turntable diameter (mm)	250
Integrated Cleaning system	Ne

## TECHNICAL FEATURES

Current (A)	10
Voltage (V)	220-240
Frequency (Hz)	50
Length of Electrical Supply Cord (cm)	135
Plug type	Ne
Timer	Yes
Grill power (W)	700
Type of grill	Quartz
Funkcija Crisp	Painted
Interior light	Yes
Additional cooking method Grill	Yes
Position of interior lights of the cavity	Right side

## ENERGY LABEL

6th Sense / Dynamic Intelligence	Ne
Number of power levels	4
Maximum micro-wave power (W)	750
Funkcija Bread defrost	Ne
Funkcija Jet defrost	Yes
Funkcija Jet Start	Yes