



SAFETY INSTRUCTIONS

IMPORTANT TO BE READ AND OBSERVED

Before using the appliance, read these safety

instructions. Keep them nearby for future reference. These instructions and the appliance itself provide important safety warnings, to be observed at all times.

The manufacturer declines any liability for failure to observe these safety instructions, for inappropriate use of the appliance or incorrect setting of controls.

⚠ Very young children (0-3 years) should be kept away from the appliance. Young children (3-8 years) should be kept away from the appliance unless continuously supervised.

Children from 8 years old and above and persons with reduced physical, sensory or mental capabilities or lack of experience and knowledge can use this appliance only if they are supervised or have been given instructions on safe use and understand the hazards involved. Children must not play with the appliance. Cleaning and user maintenance must not be carried out by children without supervision.

PERMITTED USE

⚠ CAUTION: The appliance is not intended to be operated by means of an external switching device, such as a timer, or separate remote controlled system.

⚠ This appliance is intended to be used in household and similar applications such as: staff kitchen areas in shops, offices and other working environments; farm houses; by clients in hotels, motels, bed & breakfast and other residential environments.

⚠ This appliance is not for professional use. Do not use the appliance outdoors.

⚠ The bulb used inside the appliance is specifically designed for domestic appliances and is not suitable for general room lighting within the home

(EC Regulation 244/2009).

⚠ The appliance is designed for operation in places where the ambient temperature comes within the following ranges, according to the climatic class given on the rating plate. The appliance may not work properly if it is left for a long time at a temperature outside the specified range.

Climatic Class Amb. T. (°C)

SN: From 10 to 32 °C;

ST: From 16 to 38 °C

N: From 16 to 32 °C

T: From 16 to 43 °C

⚠ This appliance does not contain CFCs. The refrigerant circuit contains R600a (HC). Appliances with Isobutane (R600a): isobutane is a natural gas without environmental impact, but is flammable. Therefore, make sure the refrigerant circuit pipes are not damaged, especially when emptying the refrigerant circuit.

⚠ WARNING: Do not damage the appliance refrigerant circuit pipes.





⚠ WARNING: Keep ventilation openings, in the appliance enclosure or in the built-in structure, clear of obstruction.

⚠ WARNING: Do not use mechanical, electric or chemical means other than those recommended by the Manufacturer to speed up the defrost process.

⚠ WARNING: Do not use or place electrical devices inside the appliance compartments if they are not of the type expressly authorised by the Manufacturer.

⚠ WARNING: Ice makers and/or water dispensers not directly connected to the water supply must be filled with potable water only.

⚠ WARNING: Automatic ice-makers and/or water dispensers must be connected to a water supply that



delivers potable water only, with mains water pressure between 0.17 and 0.81 MPa (1.7 and 8.1 bar).

⚠ Do not store explosive substances such as aerosol cans with a flammable propellant in this appliance.

⚠ Do not swallow the contents (non-toxic) of the ice packs (provided with some models). Do not eat ice cubes or ice lollies immediately after taking them out of the freezer since they may cause cold burns.

⚠ For products designed to use an air filter inside an accessible fan cover, the filter must always be in position when the refrigerator is in function.

⚠ Do not store glass containers with liquids in the freezer compartment since they may break. Do not obstruct the fan (if included) with food items. After placing the food check that the door of the compartments closes properly, especially the freezer door.

⚠ Damaged gaskets must be replaced as soon as possible.

⚠ Use the refrigerator compartment only for storing fresh food and the freezer compartment only for storing frozen food, freezing fresh food and making ice cubes.





⚠ Avoid storing unwrapped food in direct contact with internal surfaces of the refrigerator or freezer compartments.

Appliances could have special compartments (Fresh Food Compartment, Zero Degree Box, etc.). Unless specified in the specific booklet of product, they can be removed, maintaining equivalent performances.

⚠ C-Pentane is used as blowing agent in the insulation foam and it is a flammable gas.

INSTALLATION

⚠ The appliance must be handled and installed by two or more persons - risk of injury. Use protective gloves to unpack and install - risk of cuts.



⚠ Installation, including water supply (if any) and electrical connections, and repairs must be carried out by a qualified technician. Do not repair or replace any part of the appliance unless specifically stated in the user manual.

Keep children away from the installation site. After unpacking the appliance, make sure that it has not been damaged during transport. In the event of problems, contact the dealer or your nearest After-sales Service. Once installed, packaging waste (plastic, styrofoam parts etc.) must be stored out of reach of children - risk of suffocation. The appliance must be disconnected from the power supply before any installation operation - risk of electric shock. During installation, make sure the appliance does not damage the power cable - risk of fire or electric shock. Only activate the appliance when the installation has been completed.

⚠ Be careful not to damage the floors (e.g. parquet) when moving the appliance. Install the appliance on a floor or support strong enough to take its weight and in a place suitable for its size and use. Make sure the appliance is not near a heat source and that the four feet are stable and resting on the floor, adjusting them as required, and check that the appliance is perfectly level using a spirit level. Wait at least two hours before switching the appliance on, to ensure that the refrigerant circuit is fully efficient.

⚠ **WARNING:** To avoid a hazard due to instability, positioning or fixing of the appliance must be done in accordance with the manufacturer instructions. It is forbidden to place the refrigerator in such way that the metal hose of gas stove, metal gas or water pipes, or electrical wires are in contact with the refrigerator back wall (condenser coil). All dimensions and spacing needed for installation of the appliance are in the Installation instruction booklet.

ELECTRICAL WARNINGS

⚠ It must be possible to disconnect the appliance from the power supply by unplugging it if plug is accessible, or by a multi-pole switch installed upstream of the socket in accordance with the wiring rules and the appliance must be earthed in conformity with national electrical safety standards.

⚠ Do not use extension leads, multiple sockets or adapters. The electrical components must not be accessible to the user after installation. Do not use the appliance when you are wet or barefoot. Do not operate this appliance if it has a damaged power cable or plug, if it is not working properly, or if it has been damaged or dropped.

⚠ If the supply cord is damaged, it must be replaced with an identical one by the manufacturer, its service agent or similarly qualified persons in order to avoid a hazard - risk of electric shock.

CLEANING AND MAINTENANCE

⚠ **WARNING:** Ensure that the appliance is switched off and disconnected from the power supply before performing any maintenance operation; never use steam cleaning equipment - risk of electric shock.

⚠ Do not use abrasive or harsh cleaners such as window sprays, scouring cleansers, flammable fluids, cleaning waxes, concentrated detergents, bleaches or cleansers containing petroleum products on plastic parts, interior and door liners or gaskets. Do not use paper towels, scouring pads, or other harsh cleaning tools.

DISPOSAL OF PACKAGING MATERIALS

The packaging material is 100% recyclable and is marked with the recycle symbol ♻.

The various parts of the packaging must therefore be disposed of responsibly and in full compliance with local authority regulations governing waste disposal.

DISPOSAL OF HOUSEHOLD APPLIANCES

This appliance is manufactured with recyclable or reusable materials. Dispose of it in accordance with local waste disposal regulations. For further information on the treatment, recovery and recycling of household electrical appliances, contact your local authority, the collection service for household waste or the store where you purchased the appliance. This appliance is marked in compliance with European Directive 2012/19/EU, Waste Electrical and Electronic Equipment (WEEE). By ensuring this product is disposed of correctly, you will help prevent negative consequences for the environment and human health.

The symbol  on the product or on the accompanying documentation indicates that it should not be treated as domestic waste but must be taken to an appropriate collection center for the recycling of electrical and electronic equipment.

ENERGY SAVING TIPS

To guarantee adequate ventilation follow installation instructions. Insufficient ventilation at the back of the product increases energy consumption and decreases cooling efficiency. Frequent door opening might cause an increase in Energy Consumption. The internal temperature of the appliance and the Energy Consumption may be affected also by the ambient temperature, as well as location of the appliance. Temperature setting should take into consideration these factors. Reduce door opening to a minimum. When thawing frozen food, place in the refrigerator. The low temperature of the frozen products cools the food in the refrigerator. Allow warm food and drinks to cool down before placing in the appliance. Positioning of the shelves in the refrigerator has no impact on the efficient usage of energy. Food should be placed on the shelves in such way to ensure proper air circulation (food should not touch each other and distance between food and rear wall should be kept). You can increase storage capacity of frozen food by removing baskets and, if present, Stop Frost shelf. Do not worry about noises coming from the compressor which are described as normal noises in this product's Quick Guide.

HOW TO OPERATE THE REFRIGERATOR COMPARTMENT

Switching on the appliance

Starting up the appliance

The appliance features internal controls. Plug in the appliance.

When the appliance is connected to the mains, the inside light switches on each time the door is opened. The thermostat, located inside the refrigerator compartment, is used to adjust the temperature of both the refrigerator compartment and low temperature compartment (if fitted).

Appliance temperature adjustment:

The thermostat automatically adjusts the temperature inside the refrigerator compartment and the ***C*** compartment. The thermostat knob can be turned from position **1** to **7** (coldest setting) to make the internal temperature colder.

When set to **0** the appliance is switched off.

To store food for a short period of time, set the thermostat between **1 (Min)** and **3 (Med)**.

- To store food for long periods of time in the ***C*** compartment, set the thermostat to **3** or **4**.

Note:

The ambient air temperature, frequency of door opening and the position of the appliance can affect internal temperatures. These factors must be taken into account when setting the thermostat.

How to use the refrigerator compartment

Position the food as shown in the figure.

- A Cooked food
- B Fish, meat
- C Fruit and vegetables
- D Bottles
- E Cheese

Notes:

- The space between the shelves and the rear wall of the refrigerator compartment must be unobstructed to allow circulation of air.
- Do not place food in direct contact with the rear wall of the refrigerator compartment.
- Do not place hot food in the refrigerator.
- Store liquids in closed containers.

Important

Storing vegetables with high water content can cause condensation to form on the glass shelf of the crisper drawer: this will not affect the correct operation of the appliance.

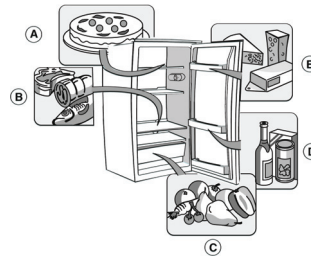

HOW TO OPERATE THE LOW TEMPERATURE COMPARTMENT

The low temperature compartment is . Frozen food can be stored in the compartment for the period of time indicated on the pack, and also fresh food can be frozen. The quantity of fresh food that can be frozen in 24 hours is shown on the rating plate.

Note:

In the event of a power cut, the low temperature compartment will maintain a sufficiently low temperature for food storage. However, it is advisable to avoid opening the compartment door during such periods.

Freezing fresh food (only in compartments marked)
Important

- Before freezing, wrap and seal fresh food in: aluminium foil, cling film, air and water-tight plastic bags, polythene containers with lids or freezer containers suitable for freezing fresh food.
- Arrange the fresh food in the top compartment, leaving sufficient space around each pack for the air to circulate.
- For optimum freezing, turn the thermostat down by half a point when placing fresh foods in the freezer compartment.
- The food will be completely frozen in 24 hours.

For appliances with compartments marked

The table alongside shows the recommended maximum storage time for frozen fresh foods.

When purchasing frozen food products:

- ensure that the packaging is not damaged (frozen food in damaged packaging may have deteriorated). If the package is swollen or has damp patches, it may not have been stored under optimal conditions and defrosting may have already begun.
- When shopping, leave frozen food purchases until last and transport the products in a thermally insulated cool bag.
- Place the items in the low temperature compartment as soon as you get home.
- If food has defrosted even partially, do not re-freeze it. Consume within 24 hours.
- Avoid, or reduce temperature variations to the minimum. Respect the best-before date on the package.
- Always observe the storage information on the package.

Making ice cubes

- Fill the ice cube tray 2/3 full and place it in the low temperature compartment
- Do not use sharp or pointed instruments to detach the tray if it is stuck to the low temperature compartment bottom.
- Bend the ice tray slightly to remove the cubes.

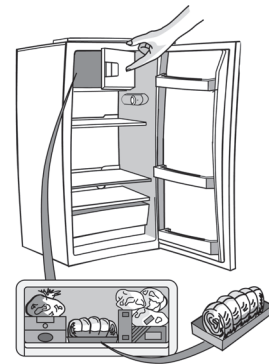

MONTHS	FOOD
1-3	
4-7	
8-12	

HOW TO DEFROST AND CLEAN THE REFRIGERATOR

Before any cleaning or maintenance operation, unplug the appliance from the mains or disconnect the electrical power supply.

Defrosting of the refrigerator compartment is completely automatic.

Droplets of water on the rear wall of the refrigerator compartment indicate that the periodic automatic defrost cycle is in progress.

The defrost water is automatically routed to a drain outlet and into a container from which it evaporates.

Regularly clean the inside of the defrost water drain hole in order to guarantee the constant and correct flow of defrost water.

Defrosting the low temperature compartment

Defrost the low temperature compartment once or twice a year or when the ice formation is excessive.

It is perfectly normal for ice to form. The amount of ice which forms and the rate at which it accumulates will depend on room temperature and humidity, and on the frequency with which the door is opened. Ice formation is concentrated at the top of the compartment and does not affect the efficiency of the appliance.

If possible, defrost the freezer when it is nearly empty.

- Remove the food from the freezer, wrap in newspaper and group together in a cool place or in a portable cooler.
- Leave the door open to allow the frost to melt.
- **Clean the interior with a sponge soaked in warm water and/or neutral detergent. Do not use abrasive substances.**
- Rinse the interior and dry thoroughly.
- Put the food back into the freezer.
- Close the door.
- Plug in the appliance once again.
- Switch the appliance on.

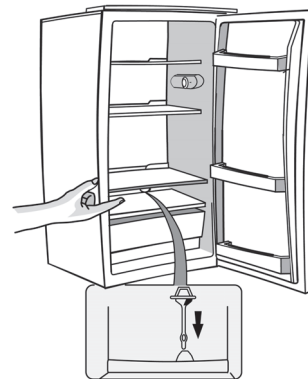

CARE AND MAINTENANCE

- Periodically clean air vents and the condenser at the rear of the appliance with a vacuum cleaner or a brush.
- Clean the outside using a soft cloth.

Prolonged disuse

1. Empty the refrigerator.
 2. Disconnect the appliance from the power supply.
 3. Defrost and clean the interior.
 4. In the event of prolonged disuse, leave the door open to prevent the formation of mould, odours and oxidation.
 5. Clean the appliance.
- Clean the inside of the low temperature compartment (where fitted) when defrosting.
 - Periodically clean the inside of the refrigerator compartment with a sponge dampened in warm water and/or neutral detergent. Rinse and dry with a soft cloth. Do not use abrasive products.
 - Clean the outside with a soft damp cloth. Do not use abrasive products, scourers, stain-removers (e.g. acetone, trichloroethylene) or vinegar.

Replacing LED:**When replacing LED, proceed as follows:**

Unplug the appliance from mains

1. Take out the screw cover with Slotted screwdriver (Pic 1)
2. Unscrew the screw with Cross screwdriver (Pic 2)
3. Take out control box (Pic 3)
4. Remove LED with slotted screwdriver (Pic 4)
5. Take out LED and replacing a new LED (Pic 5)
6. Fix the new LED with slotted screwdriver (Pic 6)
7. Fix the control box (Pic 3, 2, 1)
8. Wait 5 minutes before plugging the appliance back into mains.

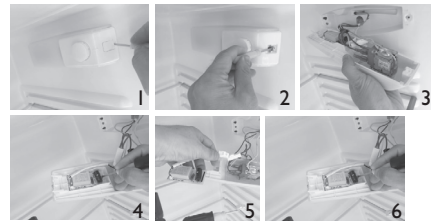

TROUBLESHOOTING GUIDE

When you hear these noises

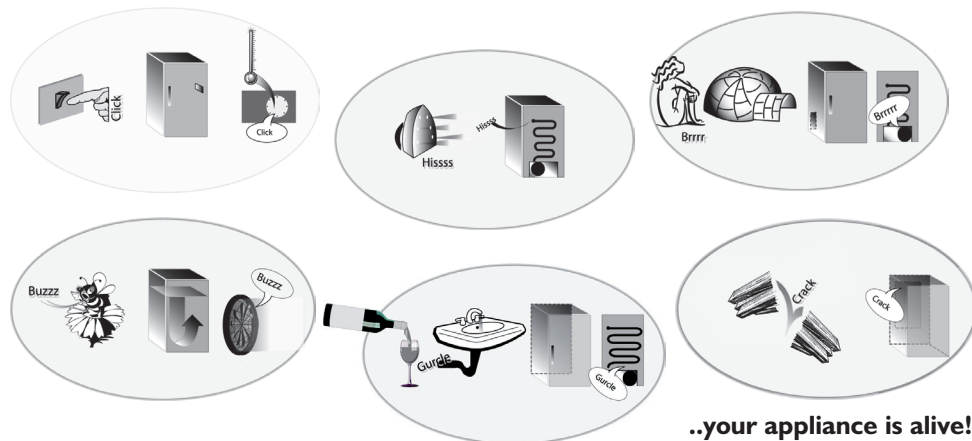
**..your appliance is alive!!!****1. The appliance is not working.**

- Is there a power failure?
- Is the plug properly inserted in the socket?
- Is the double-pole switch on?
- Has the fuse blown?
- Is the power cord damaged?
- Is the thermostat set to ● (Stop)?

2. Temperature inside the compartments is not low enough.

- Is the door shut properly?
- Is food obstructing proper door closure?
- Is the appliance installed near a heat source?
- Is the thermostat setting correct?
- Are the air circulation vents blocked?

3. Temperature inside the refrigerator compartment is too low.

- Is the thermostat setting correct?

4. The appliance is excessively noisy.

- Has the appliance been installed correctly?
- Are the pipes at the back touching or vibrating?

5. Water collects at the bottom of the refrigerator compartment.

- Is the defrost water drain blocked?

6. Excessive frost build-up in the low temperature compartment.

- Is the door shut properly?
- Is food obstructing proper door closure?

Notes:

- Gurgling and hissing noises due to expansion in the refrigerant circuit are normal.

AFTER-SALES SERVICE

Before contacting After-Sales Service:

1. See if you can solve the problem yourself with the help of the "Troubleshooting guide").
2. Switch the appliance on again to see if the problem has been solved. If it has not, disconnect the appliance from the power supply and wait for about an hour before switching on again.
3. If the problem persists after this course of action, contact After-sales Service.

Specify:

- the nature of the problem
- the model
- the Service number (the number after the word SERVICE on the rating plate on the inside of the appliance)
- your full address
- your telephone number and area code.

SERVICE 0000 000 00000



INSTALLATION

- Install the appliance away from heat sources. Installation in a hot environment, direct exposure to the sun or installation near heat sources (heaters, radiators, cookers) will increase power consumption and should therefore be avoided.
- If this is not possible, the following minimum distances must be respected:
 - 30 cm from coal or paraffin stoves;
 - 3 cm from electric and/or gas stoves.
- To optimize appliance efficiency, leave a 5 cm gap above the appliance and make sure that adjacent kitchen units are sufficiently distanced to allow air circulation.
- Install the appliance in a dry, well-ventilated place, and ensure it is level, using the front adjustment feet if necessary.
- Clean the interior.
- Fit the accessories.

Electrical connection

- Electrical connections must be made in accordance with local regulations.
- Voltage and power consumption are indicated on the rating plate inside the appliance.
- Regulations require that the appliance is earthed. The Manufacturer declines all liabilities for injury to persons or animals or damage to property resulting from failure to observe these regulations.
- If the plug and socket are not of the same type, have the socket replaced by a qualified electrician.
- Do not use extension leads or adapters.

Disconnecting the appliance

It must be possible to disconnect the appliance by unplugging it or by means of a two-pole switch fitted upline of the socket.

Door Swing Reversal

Reversing the door swing

The refrigerator has the capability of opening the door from either the left or the right side.

The unit is delivered to you with the door opening from the left side. To change the opening direction, please follow these instructions.

Note: Before reversing the door swing, unplug the appliance from the mains or disconnect the electrical power supply.

1. Remove the screws (6) holding the top panel (7) to the unit. Remove the top panel
2. Remove the two screws (1) holding the top hinge (5) (right side) to the frame. Remove the top hinge (5).
3. Lift the door off the bottom hinge pin and place it on a non-scratching surface.
4. Remove the two screws (8) holding the bottom hinge (2). Remove the bottom hinge (2).
5. Remove the left front leg (4) and transfer it to the right side.
6. Before replacing the bottom hinge (2), remove the hinge pin (9) and reverse the direction of the hinge (2). Reassemble the bottom hinge (2) on the left hand side using the two screws (8).
7. Refit the hinge pin (9) into the bottom hinge (2).
8. Lower the door onto the bottom hinge pin (9).
9. While holding the door in the closed position, reassemble the top hinge (5) on the left hand side using the two screws (1). Do not tighten the screws (1) until the top of the door is level with the counter top.
10. Refit the top panel using the screws (6).

Note:

The direction of door opening can be changed.
If this operation is performed by After-sales Service it is not covered by the warranty.

Reversing the Inside Compartment Door Swing

1. Remove the door support pin screw at the bottom right;
2. remove the cap on the left part;
3. remove the two screw caps on the left part;
4. undo the two screws;
5. refit everything on the opposite side.

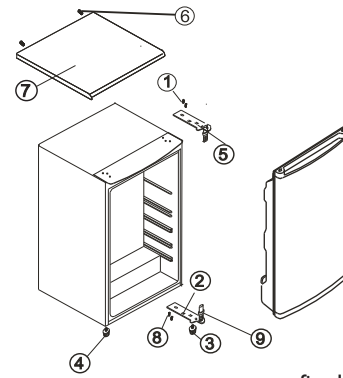

Door opening from left side fig. 1

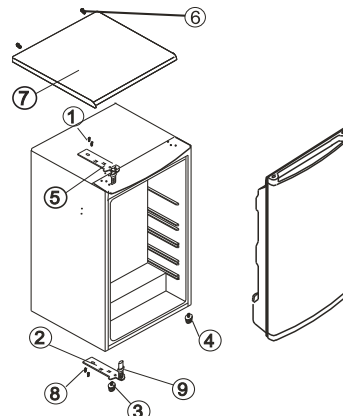

Door opening from right side fig. 2

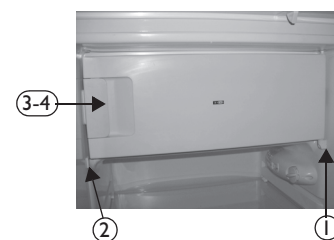

TOP REMOVABLE

REFRIGERATION TABLE TOP 54 CM

HOW TO REMOVE THE TOP BEFORE TO PLACE THE APPLIANCE IN BUILT IN POSITION

Operation n°1

To dismount the 2 screws on the back side of the product

Operation n°2

To lift up from rear the top, and remove it from front fixation

Operation n°3

To dismount the 10 screws on the front plastic frame and metal hinge

Operation n°4

To move out the hinge and the plastic frame

Operation n°5

To replace and to refit the metallic hinge with 2 screws



screws

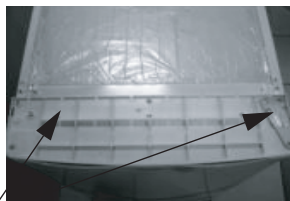

screws

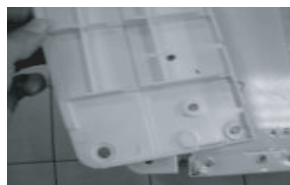

screws



ELECTRICAL CONNECTION

1) For Great Britain only

Warning - this appliance must be earthed

Fuse replacement

If the mains lead of this appliance is fitted with a BS 1363A 13amp fused plug, to change a fuse in this type of plug use an A.S.T.A. approved fuse to BS 1362 type and proceed as follows:

1. Remove the fuse cover (A) and fuse (B).
2. Fit replacement 13A fuse into fuse cover.
3. Refit both into plug.

Important:

The fuse cover must be refitted when changing a fuse and if the fuse cover is lost the plug must not be used until a correct replacement is fitted.

Correct replacement are identified by the colour insert or the colour embossed in words on the base of the plug.

Replacement fuse covers are available from your local electrical store.

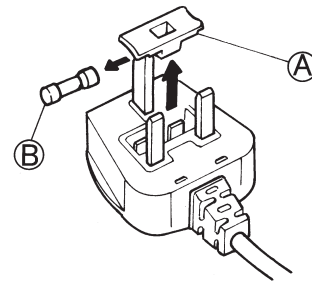

2) For the Republic of Ireland only

The information given in respect of Great Britain will frequently apply, but a third type of plug and socket is also used, the 2-pin, side earth type.

3) Socket outlet / plug (valid for both countries)

If the fitted plug is not suitable for your socket outlet, please contact Whirlpool Service for further instruction. Please do not attempt to change plug yourself. This procedure needs to be carried out by a qualified Whirlpool technician in compliance with the manufactures instructions and current standard safety regulations.