

FFT CM10 8B UK

12NC: 859991635210

GTIN (EAN) code: 8003437624766

Whirlpool

SENSING THE DIFFERENCE

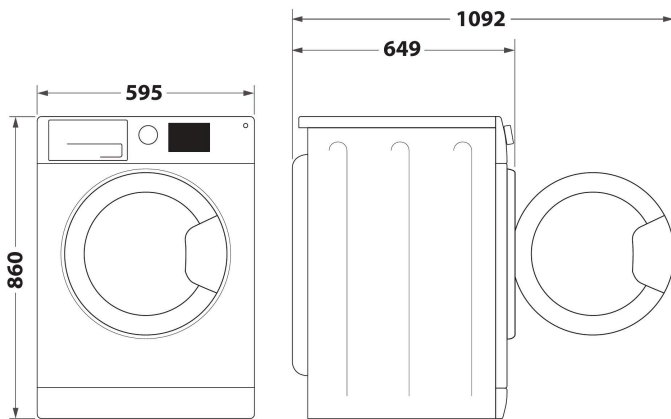

- Energy class B
- Drying capacity: 8,0 kg
- White finishing
- 6TH Sense Technology
- Condenser technology
- FreshCare+
- Start delay 1-9h
- Drying time
- Delicates
- Adjustable dryness levels
- Rapid program
- Eco Cotton
- Wool
- Mixed Fabrics Program
- Special big items
- Jeans
- Sport

Whirlpool condenser tumble dryer: freestanding, 8,0kg - FFT CM10 8B UK

This Whirlpool freestanding Tumble Dryer features: spacious 8,0kg capacity drum. Exclusive 6th SENSE technology that constantly monitors the moisture in the drum, protecting your clothes and providing ideal drying results. Condenser technology providing improved, energy efficient results compared to standard vented dryers.



Quiet

This Whirlpool Dryer is designed to produce limited noise output.



6th Sense

6th Sense automatically detects the amount of laundry and sets the right drying cycle time, guaranteeing the desired dryness level, with time and energy optimization.



FreshCare+

Keep your garments fresh up to 6 hours after the cycle is over*. Innovative FreshCare+ system takes care of your garments inside the dryer thanks to intelligent delicate temperature control and delicate tumbling action that keep garments fresh and prevent bad odours. FreshCare+ treatment leaves truly fresher clothes and peace of mind - even hours after the end of the cycle. *FreshCare+ treatment inhibits the proliferation of the main bad odour sources (inside the dryer) up to 6 hours after the drying ends. Not compatible with programmes designed for delicate garments and with extra and cupboard drying levels.



8kg capacity

All the space you need. With its 8kg drum capacity, this Whirlpool Dryer provides all the space you need for your laundry.



Energy Class B

This Whirlpool Dryer is an Energy Class B appliance.



Drum finiture

This Dryer drum features a special pattern and lifters, designed to provide excellent drying results, and ideal care for all garments.



Direct Drain

Forget about emptying the water tank. Save time and effort by connecting your dryer's drain hose to drain pipe.



Easy Cleaning

Easily remove and clean the filter in only three simple steps

FFT CM10 8B UK

12NC: 859991635210

GTIN (EAN) code: 8003437624766

Whirlpool

SENSING THE DIFFERENCE

MAIN FEATURES

Product group	Dryer
Commercial code	FFT CM10 8B UK
GTIN (EAN) code	8003437624766
Construction type	Free-standing
Installation type	Free-standing
Removable work top	No
Loading type	Front loader
Main colour of product	White
Electrical connection rating (W)	2700
Current (A)	13
Voltage (V)	220-240
Frequency (Hz)	50
Length of Electrical Supply Cord (cm)	150
Plug type	UK
Height of the product	860
Width of the product	595
Depth of the product	649
Depth with open door 90 degree (mm)	1092
Net weight (kg)	37

TECHNICAL FEATURES

Automatic programmes	No
Moisture monitoring system	Yes
Adjustable drying temperature	No
Progress indicator	Yes
Digital countdown indicator	Yes
Start delay options	One time fixed
Start delay time max. (h)	9
Blocked filter indicator	Yes
Full tank indicator	Yes
Quick dry	No
Anti-crease function	Yes
Drum volume (l)	120

PERFORMANCES

Energy efficiency class - NEW (2010/30/EU)	B
Condensation efficiency class - NEW (2010/30/EU)	B
Energy consumption electric dryer, full load - NEW (2010/30/EU)	4,72
Weighted condensation efficiency	81
Weighted annual energy consumption, electric dryer - NEW (2010/30/EU)	562,0
Capacity cotton (kg) - NEW (2010/30/EU)	8,0
Dryer type	Condenser
Noise level (dB(A) re 1 pW)	66
Standard cotton programme time at full load	130
Standard cotton programme time at partial load	80
Weighted programme time	101
Power consumption in left-on mode - NEW (2010/30/EU)	2,00
Duration of the left-on mode - NEW (2010/30/EU)	15
Power consumption in off-mode - NEW (2010/30/EU)	0,13

ENERG Y IJA
енергия · ενεργεια
IE IA

WHIRLPOOL
FFT CM10 8B UK

A+++
A++
A+
A
B
C
D

B

562,0
kWh/annum

ENERGIA · ЕНЕРГИЯ · ENERGIEIA
ENERGIJA · ENERGY · ENERGIE
ENERGI

130
min/cycle*

8,0
kg

66
dB

ABCDEFG

* λικνση · ciklus · portion · zklus
tipolozovani · ciklo · tsikluel
ohjelma · ciklus · ciklas · cikls
ciklu · cyclus · cykl · ciclu
program · taskompling

392/2012