

# AKZ9S 8271 IX

12NC: 859991670640

GTIN (EAN) code: 8003437836237

Whirlpool

SENSING THE DIFFERENCE

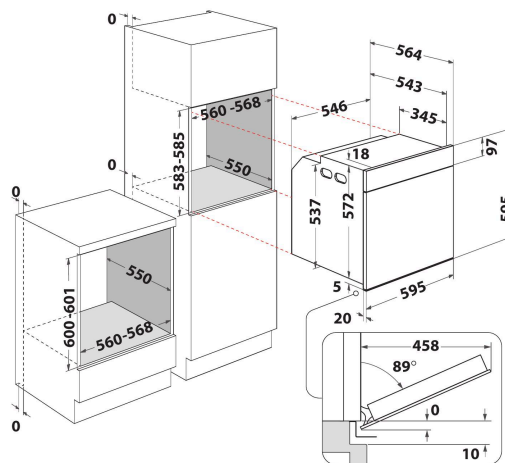

- 6TH Sense technology
- Up to 40 6th SENSE Cooking Combinations
- Energy class A+
- Cavity 73 L
- Cook3
- Ready2Cook
- SteamSense: steam 25 and 50%
- Forced Air Fan Cooking
- Turbo Fan
- Grill
- Easy Clean Enamel Interior
- Turbo grill function
- Maxi cooking
- Pastry function
- Pizza/Bread function
- Eco Forced Air
- Warm Keeping

## Whirlpool built in electric oven: inox color - AKZ9S 8271 IX

This Whirlpool built in Oven features: advanced electric technology allowing you to cook dishes saving energy. Halogen lamp allowing a more energy-efficient performance. Exclusive 6th SENSE technology, that allows you to pick among a variety of pre-programmed recipes, and your oven will automatically adjust cooking, temperature and time settings, to ensure perfect results. Innovative Cook3 function, that allows you to cook up to three separate dishes at the same time, without the risk of aromas mixing. Oven door with soft-close design, for increased ease of use.



### Multifunction 8

Multiple cooking methods. The Multifunction 8 feature offers flexible cooking options, to ensure perfect results, whatever the recipe.



### 6th Sense Absolute

Thanks to the 6TH SENSE Technology, the oven will manage the temperature and cooking time for you. The cooking process is fully automated and will stop once the dish is perfectly cooked.



### Ready2cook

No pre-heating required. The Ready2Cook function uses a powerful convection system to quickly reach the right temperature, and completely eliminate the need for pre-heating.



### SteamSense

A combination of heat and steam injection with three levels of steam to cook your favorite recipes and get soft, crispy and juicier results. It maintains the nutrients and enhances taste.



### Forced Air

Seal in the taste. Thanks to the Forced Air technology, preheated air is circulated inside your Oven using an innovative convection system, giving you moist, juicy cooking results.



### FlexiClean

Two cleaning options in the same oven, allowing you to clean it effortlessly no matter the occasion.



### Pyrolytic technology

Spotless cleaning at the touch of a button. Pyrolytic technology uses a high-temperature cycle to burn food residues into ashes, which can then be easily wiped away with a sponge. Heat-reflecting glass panels in the oven door ensure that the external temperature stays low, for added safety.

# AKZ9S 8271 IX

12NC: 859991670640

GTIN (EAN) code: 8003437836237

**Whirlpool**

SENSING THE DIFFERENCE

## MAIN FEATURES

Product group	Oven
Commercial code	AKZ9S 8271 IX
Main colour of product	Inox
Construction type	Built-in
Type of control	Electronic
Type of control settings	-
Are any hobs controls integrated?	No
Which kind of hobs can be controlled?	-
Automatic programmes	Yes
Current (A)	16
Voltage (V)	220-240
Frequency (Hz)	50/60
Length of Electrical Supply Cord (cm)	90
Plug type	No
Depth with open door 90 degree (mm)	-
Height of the product	595
Width of the product	595
Depth of the product	564
Minimum niche height	0
Minimum niche width	0
Niche depth	0
Net weight (kg)	38
Usable volume (of cavity)	73
Integrated Cleaning system	Pyrolytic+Hydrolytic
Grids of the cavity	1
Trays	3

## TECHNICAL FEATURES

Timer	Yes
Time control	Electronic
Time-setting options	Start and Stop
Safety device	-
Interior light	Yes
Number of interior lights of the cavity	1
Position of interior lights of the cavity	Rear
Oven guides of the cavity	Telescopic
Probe of the cavity	No

## PERFORMANCES

Energy input	Electric
Type of energy of the cavity	Electricity
Energy efficiency class - NEW (2010/30/EU)	A+
Energy consumption per cycle conventional - NEW (2010/30/EU)	0.90
Energy consumption per cycle forced air convection - NEW (2010/30/EU)	0.69

**ENERG** Y UA  
енергия · ενεργεια IE IA

**WHIRLPOOL** AKZ9S 8271 IX

**A+**

73 l

0.90 kWh/cycle\*

0.69 kWh/cycle\*

\* ημερησια · cyklus · portion · zykus · nopolyqayua · ciclo · tsükkel · ohjelma · ciklus · cikls · ciklu · cycles · cykl · ciclu · program · cykel

65/2014