

# AKT 109 NE

12NC: 859410901000

GTIN (EAN) code: 8003437829055

Whirlpool

SENSING THE DIFFERENCE

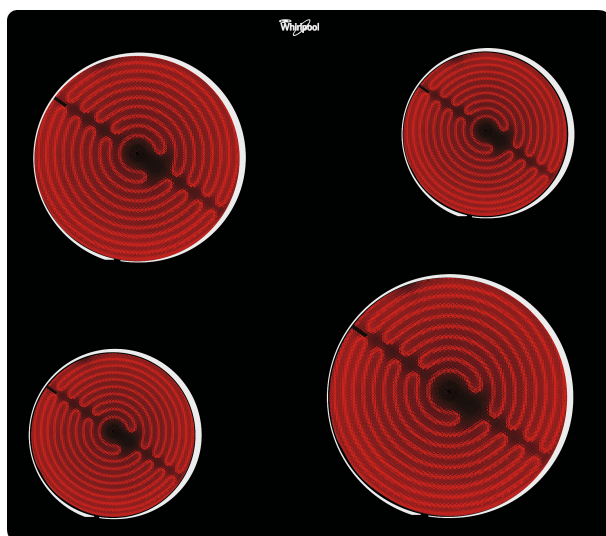

## Whirlpool hob - AKT 109 NE

This Whirlpool Hob features: electric power supply.



### Under the Counter

Effortlessly access your hob via your oven's control panel, for increased ease of use.

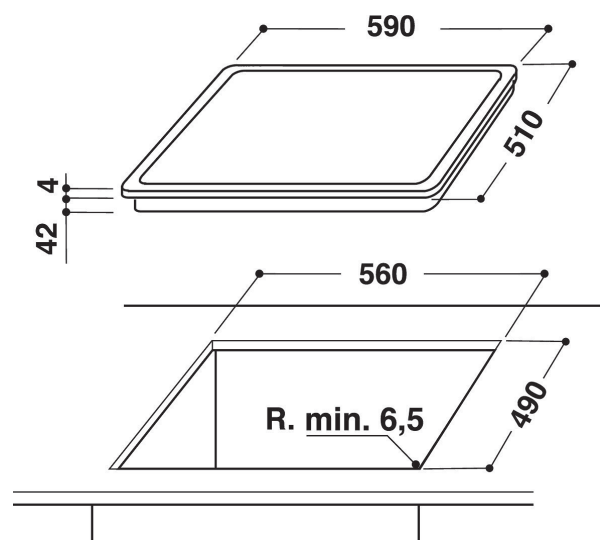

- External controls
- 60 cm hob
- Mechanical control
- Black Glass Hob
- 4 Radiant cooking zones
- Supply cord included
- 4 Cooking zones: 1 Radiant 1200 W, 1 Radiant 1700 W, 1 Radiant 1200 W, and 1 Radiant 2100 W
- Frameless
- Dimensions HxWxD: 46x580x510 mm
- Niche dimensions HxWxD: 42x560x490 mm
- Electrical Connection Rating: 6200 W
- Voltage: 230 V
- Front left zone: 145 mm  $\varnothing$ , 1200 W
- Rear left zone: 180 mm  $\varnothing$ , 1700 W
- Rear right zone: 145 mm  $\varnothing$ , 1200 W
- Front right zone: 210 mm  $\varnothing$ , 2100 W

# AKT 109 NE

12NC: 859410901000

GTIN (EAN) code: 8003437829055

**Whirlpool**

SENSING THE DIFFERENCE

## MAIN FEATURES

|                                       |            |
|---------------------------------------|------------|
| Product group                         | Hob        |
| Construction type                     | Built-in   |
| Type of control                       | Mechanical |
| Type of control settings              | -          |
| Number of gas burners                 | 0          |
| Number of electric cooking zones      | 4          |
| Number of electric plates             | 0          |
| Number of radiant plates              | 4          |
| Number of halogen plates              | 0          |
| Number of induction plates            | 0          |
| Number of electric warming zones      | 0          |
| Location of control panel             | External   |
| Basic surface material                | Glass      |
| Main colour of product                | Black      |
| Electrical connection rating (W)      | 6200       |
| Gas connection rating (W)             | 0          |
| Gas type                              | N/A        |
| Current (A)                           | 26         |
| Voltage (V)                           | 230        |
| Frequency (Hz)                        | 50/60      |
| Length of Electrical Supply Cord (cm) | 0          |
| Plug type                             | No         |
| Gas connection                        | N/A        |
| Width of the product                  | 580        |
| Height of the product                 | 46         |
| Depth of the product                  | 510        |
| Minimum niche height                  | 42         |
| Minimum niche width                   | 560        |
| Niche depth                           | 490        |
| Net weight (kg)                       | 8          |
| Automatic programmes                  | No         |

## TECHNICAL FEATURES

|                         |                       |
|-------------------------|-----------------------|
| Power on indicator      | No                    |
| Number of indicators    | 0                     |
| Type of regulation      | Step energy regulated |
| Type of lid             | Without               |
| Residual heat indicator | Without               |
| Main on/off switch      | No                    |
| Safety device           | -                     |
| Timer                   | No                    |

## PERFORMANCES

|              |          |
|--------------|----------|
| Energy input | Electric |
|--------------|----------|