

FFD 10449 CV GCC

12NC: 859991642040

GTIN (EAN) code: 8003437628429

Whirlpool

SENSING THE DIFFERENCE

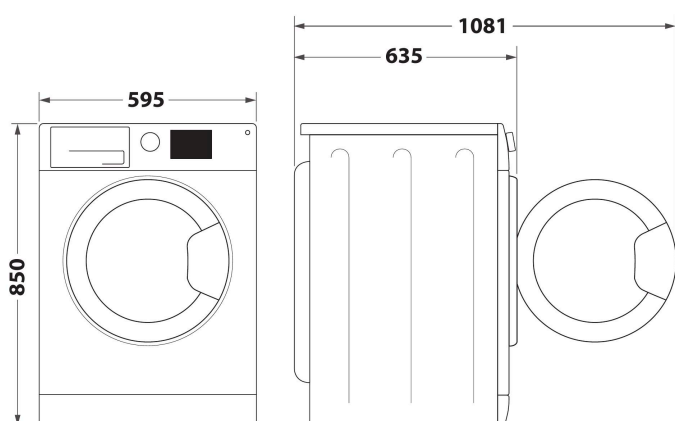

- Energy class A+++
- Washing capacity: 10 kg
- Maximum spin speed: 1400 rpm
- 6TH Sense Technology
- FreshCare+
- Daily 30°
- Daily 40°
- Daily mixed 40°C
- Eco Cotton
- Steam refresh
- Mixed Fabrics Program
- Special Big Items Program
- Sport
- Lingerie Program
- Delicates
- Program Progress Indicators
- Program cancellation

Whirlpool freestanding front loading washing machine: 10 kg - FFD 10449 CV GCC

This Whirlpool freestanding Washing Machine features: white color. A spacious, large 10kg capacity. A fast, resource-efficient 1400 revolutions per minute spin speed. Exclusive 6th SENSE technology, that dynamically adapts settings to each specific load, ensuring ideal care for all your fabrics. Outstanding A+++ energy rating, effectively reducing energy consumption by 10%.



6th Sense Technology

Discover perfect care. 6th SENSE intelligent sensors adapt resources according to the size and type of load, offering time, energy and water optimization.



FreshCare+

100% Freshness even if you forget to unload. No need to adapt your schedule to the laundry chores: your garments will be protected from odours and creasing. FreshCare+ thanks to delicate steaming and tumbling action inhibits the proliferation of the main bad odour sources (inside the washer) for up to 6 hours after the cycle ends, while gentle tumbling prevents fixing of creases.



Steam Hygiene

Laundry is sanitized in the most natural and delicate way at the end of the washing cycle - even when washing at low temperatures - without chemical additives. Ideal for those with sensitive skins, and good for the environment as well, this treatment removes up to 99.9% of the most common bacteria.



Sense Inverter Motor

Silent performance. This Whirlpool Washing machine's innovative SENSE Inverter Motor is designed to ensure a long lasting, silent performance. Enjoy both ideal results and some extra peace and quiet.



1400 rpm

Outstanding speed. This Whirlpool Washing Machine features a 1400 rounds per minute spin speed.



Super Energy efficiency: A+++ -10%

Unparalleled energy efficiency. This Whirlpool Washing Machine features an outstanding A+++ energy rating, reducing energy consumption by 10%.



10kg capacity

All the space you need. With its 10kg drum capacity, this Whirlpool Washing Machine provides all the space you need for your laundry.

FFD 10449 CV GCC

12NC: 859991642040

GTIN (EAN) code: 8003437628429

Whirlpool

SENSING THE DIFFERENCE

MAIN FEATURES

Product group	Washing machine
Construction type	Free-standing
Installation type	Free-standing
Removable work top	No
Loading type	Front loader
Main colour of product	White
Electrical connection rating (W)	1850
Current (A)	10
Voltage (V)	220-240
Frequency (Hz)	50
Length of Electrical Supply Cord (cm)	120
Plug type	UK
Height of the product	850
Width of the product	595
Depth of the product	605
Net weight (kg)	71.6

TECHNICAL FEATURES

Automatic programmes	Yes
Spin speed options	Variable
Skip spin	Yes
Weight measurement	-
Textile type recognition	-
Degree of dirtiness recognition	-
Foam control	Yes
Balance control	Yes
Type of water protection system	No
Cold wash option	No
Progress indicator	DISPLAY
Digital countdown indicator	Yes
Start delay options	Continuous
Start delay time max. (h)	0
Tub material	Plastic
Drum volume (l)	71
Hot & cold water intake?	No
Gross weight (kg)	73.2
Height of the packed product	890
Width of the packed product	645
Depth of the packed product	670

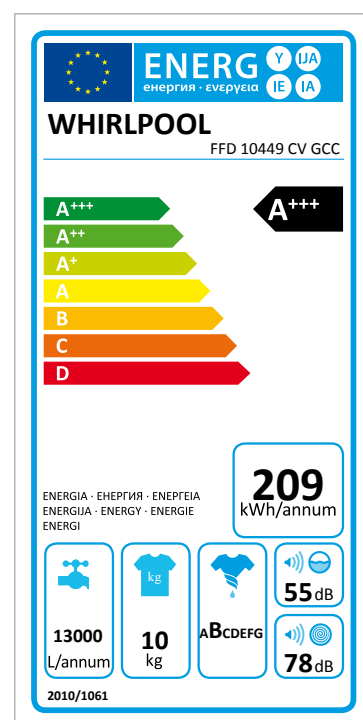

PERFORMANCES

Energy efficiency class - NEW (2010/30/EU)	A+++
Energy consumption annual (kWh/annum) - NEW (2010/30/EU)	209
Washing performance class	A
Maximum spin speed (rpm) - NEW (2010/30/EU)	1400
Capacity cotton (kg) - NEW (2010/30/EU)	10
Water consumption annual (l/annum) - NEW (2010/30/EU)	13000
Energy consumption 60 °C full load	1.155
Power consumption in left-on mode - NEW (2010/30/EU)	8
Power consumption in off-mode - NEW (2010/30/EU)	0.5
Moisture content % on dry load after max. spin - NEW (2010/30/EU)	53
Average washing time cotton 60°C (full load) - NEW (2010/30/EU)	225
Noise level washing (dB(A) re 1 pW)	55
Noise level spinning (dB(A) re 1 pW)	78