

# WSIO 3T223 PCE X UK

12NC: 859991552740

GTIN (EAN) code: 8003437233098

Whirlpool

SENSING THE DIFFERENCE

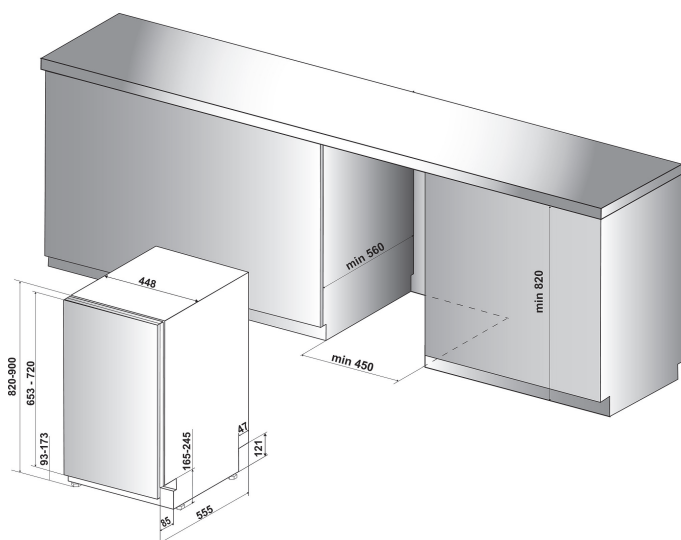

- Installation Type: Built-in
- Energy class A++
- 10 place settings
- Model only 45 cm wide
- 6TH Sense Technology
- Noise level: 43 dB(A)
- 9 L per cycle (2520 L per year)
- PowerCleanPro
- PowerCleanPRO
- Third rack: Tray
- Autoclean filter
- Start delay 1-12 h
- FlexiSpace
- Adjustable upper rack
- Multizone
- Cutlery basket
- Tablet

## Whirlpool integrated dishwasher: inox color, slimline - WSIO 3T223 PCE X UK

This Whirlpool integrated Dishwasher features: inox color. Outstanding A++ energy rating, for reduced energy consumption. Adjustable feet, for perfect stability on uneven floors and surfaces. Innovative technology ensuring extra silent performance, for a very quiet appliance. Superb cleaning performance, for ideal washing results.



### Single rack washing option

Outstanding water efficiency. The single rack option allows you to wash a small number of dishes without having to wait to fill your Dishwasher. Enjoy perfect results and low water consumption.



### Start Delay

Tailored for you. The Start Delay option allows you to set the Dishwasher to begin its cycle whenever most convenient for you, saving you both time and energy.



### EcoFriendly

Extraordinary savings. 6th SENSE EcoFriendly technology features intelligent sensors to continuously monitor the wash cycle and detect the level of soiling, adjusting resources accordingly. Enjoy ideal cleaning results and save up to 50% energy, water and time.\* (\*Comparison between minimum and maximum consumption on the 6th SENSE programs.)



### 10 Place Settings

All the space you need. This Whirlpool Dishwasher provides 10 versatile place settings, so you can enjoy all the space you need, always.



### Silent

Silent performance. Your Whirlpool Dishwasher is designed to provide ideal washing results, while ensuring the lowest possible noise output.



### 6th Sense

No prewash required. technology provides perfect washing results with no pre-washing, soaking or scrubbing by hand, while effectively reducing water consumption and costs.



### Powerclean Pro

Powerful water jets on the rear of the machine work to deliver supreme cleaning results on the toughest soil. The intelligent sensors detect the level of dirt and adapt the water pressure accordingly.



### Flexible washing options

Ideal space management. Add, remove or adapt the space inside your Dishwasher as you like, thanks to the modular racks and foldable tines.

# WSIO 3T223 PCE X UK

12NC: 859991552740

GTIN (EAN) code: 8003437233098

**Whirlpool**

SENSING THE DIFFERENCE

## MAIN FEATURES

Construction type	Built-in
Installation type	Full-integrated
Type of control	Electronic
Type of control settings	-
Removable work top	N/A
Door decor panel	N/A
Main colour of product	Inox
Electrical connection rating (W)	1900
Current (A)	13
Voltage (V)	220-240
Frequency (Hz)	50
Length of Electrical Supply Cord (cm)	130
Plug type	UK
Length inlet hose (cm)	155
Length outlet hose (cm)	150
Adjustable plinth	No
Height of removable worktop (mm)	0
Adjustable feet	Yes - all from front
Height of the product	820
Width of the product	448
Depth of the product	555
Depth with open door 90 degree (mm)	-
Minimum niche height	820
Maximum niche height	900
Minimum niche width	450
Maximum niche width	600
Niche depth	560
Net weight (kg)	29.6
Gross weight (kg)	31.6

## TECHNICAL FEATURES

Automatic programmes	Yes
Maximum temperature for water intake (°C)	60
Start delay options	Continuous
Start delay time max. (h)	12
Progress indicator	-
Digital countdown indicator	Yes
Salt light indicator	Yes
Rinse aid light indicator	Yes
Safety device	N/A
Adjustable upper basket	Yes
Largest loadable dish upper basket (cm)	0
Largest loadable dish lower basket (cm)	0
Number of place settings	10

## PERFORMANCES

Energy efficiency class - NEW (2010/30/EU)	A++
Energy consumption annual (kWh/annum) - NEW (2010/30/EU)	212
Duration of the left-on mode - NEW (2010/30/EU)	12
Power consumption in left-on mode - NEW (2010/30/EU)	5
Power consumption in off-mode - NEW (2010/30/EU)	0.5
Water consumption annual (l/annum) - NEW (2010/30/EU)	2520
Noise level (dB(A) re 1 pW)	43

**ENERG** Y IJA  
енергия · ενεργεια IE IA

**WHIRLPOOL**  
WSIO 3T223 PCE X UK

A+++  
A++  
A+  
A  
B  
C  
D

**A++**

**212**  
kWh/annum

ENERGIA · ЕНЕРГИЯ · ΕΝΕΡΓΕΙΑ  
ENERGIJA · ENERGIY · ENERGIJE  
ENERGI

2520  
L/annum

ABCDEFG

X 10

43  
dB

2010/1059