

WMD44ME

12NC: 859991682260

GTIN (EAN) code: 8003437397295

Whirlpool

SENSING THE DIFFERENCE

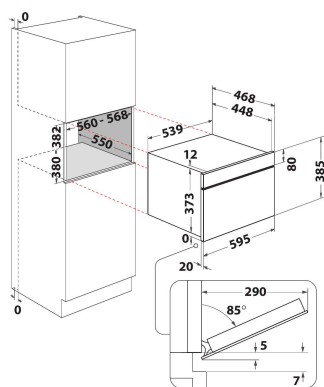

MAIN FEATURES

| | |
|---------------------------------------|--------------------|
| Product group | Mikrovalna pećnica |
| Commercial code | WMD44ME |
| Main colour of product | Urban beige |
| Type of micro-wave oven | MW+Grill function |
| Construction type | Ugradbeni |
| Type of control | Electronic |
| Type of control settings | LED |
| Additional cooking method Grill | Yes |
| Funkcija Crisp | Yes |
| Steam | Ne |
| Additional cooking method Fan cooking | Ne |
| Clock | Yes |
| Automatic programmes | Yes |
| Height of the product | 385 |
| Width of the product | 595 |
| Depth of the product | 468 |
| Minimum niche height | 380 |
| Minimum niche width | 556 |
| Niche depth | 550 |
| Net weight (kg) | 27 |
| Ljubičasta sa bisernim odsjajem | 31 |
| Turntable | Yes |
| Turntable diameter (mm) | 325 |
| Integrated Cleaning system | Hydrolytic |

TECHNICAL FEATURES

| | |
|---|-----------------|
| Current (A) | 10 |
| Voltage (V) | 220-240 |
| Frequency (Hz) | 50 |
| Length of Electrical Supply Cord (cm) | 135 |
| Plug type | Schuko |
| Timer | Yes |
| Grill power (W) | 800 |
| Type of grill | Quartz |
| Funkcija Crisp | Stainless steel |
| Interior light | Yes |
| Additional cooking method Grill | Yes |
| Position of interior lights of the cavity | Right side |

ENERGY LABEL

| | |
|----------------------------------|--------------------|
| 6th Sense / Dynamic Intelligence | Tehnologija 6.ČULO |
| Number of power levels | 7 |
| Maximum micro-wave power (W) | 1000 |
| Funkcija Bread defrost | Ne |
| Funkcija Jet defrost | Yes |
| Funkcija Jet Start | Yes |