



**THANK YOU FOR BUYING A WHIRLPOOL PRODUCT**  
In order to receive a more complete assistance, please register your product on [www.whirlpool.eu/register](http://www.whirlpool.eu/register)



Before using the appliance carefully read the Safety Instruction.

**PLEASE SCAN THE QR CODE ON YOUR APPLIANCE IN ORDER TO REACH MORE INFORMATION**

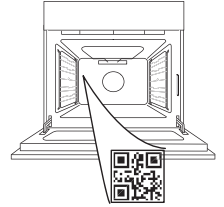

## PRODUCT DESCRIPTION

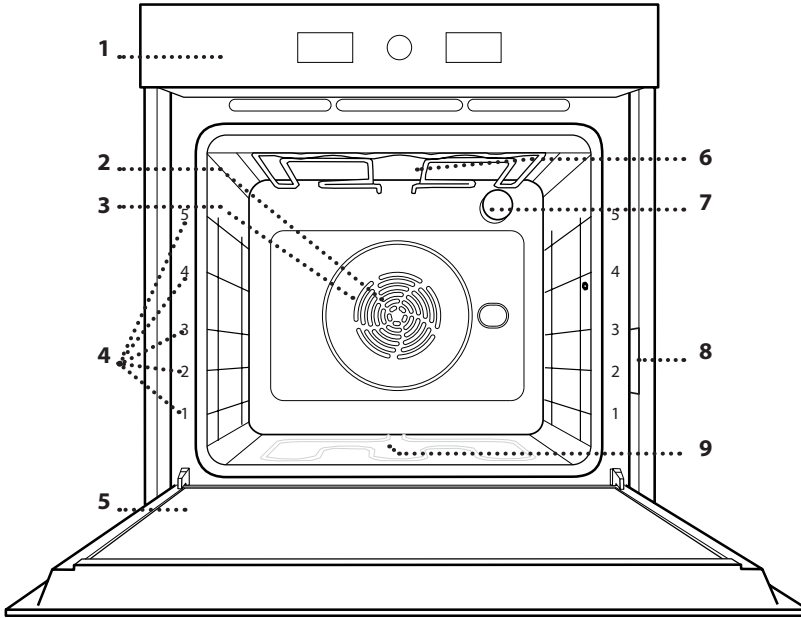

1. Control panel
2. Fan
3. Circular heating element (non-visible)
4. Shelf guides (the level is indicated on the front of the oven)
5. Door
6. Upper heating element/grill
7. Lamp
8. Identification plate (do not remove)
9. Lower heating element (non-visible)

## CONTROL PANEL

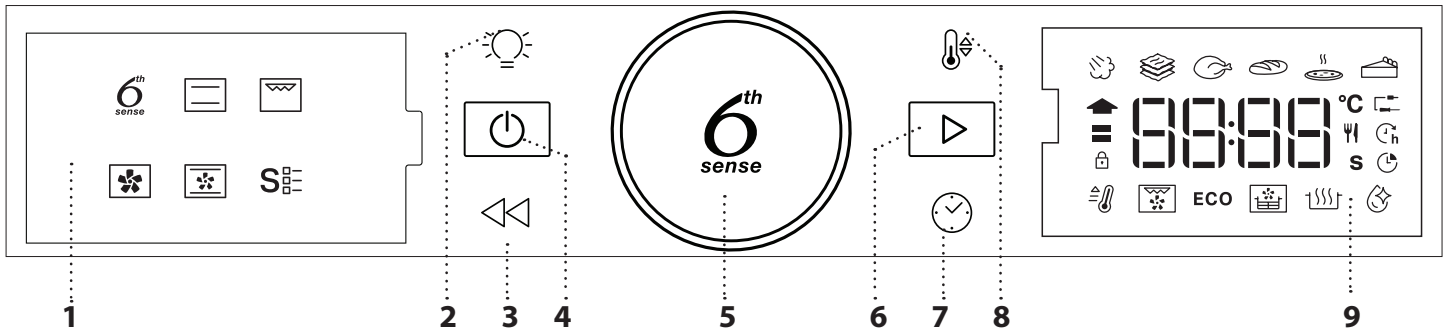

### 1. LEFT HAND DISPLAY

#### 2. LIGHT

For switching the lamp on/off.

#### 3. BACK

For returning to the previous screen. During cooking, allows settings to be changed.

#### 4. ON/OFF

For switching the oven on and off and for stopping an active function at any time.

### 5. ROTARY KNOB

Turn this to navigate through the functions and adjust all of the cooking parameters. Press to select, set, access or confirm functions or parameters and eventually start the cooking program.

### 6. START

For starting functions and confirming settings or a set value.

#### 7. TIME

For setting the time as well as setting or adjusting the cooking time.

#### 8. TEMPERATURE

For setting the temperature.

#### 9. RIGHT-HAND DISPLAY

# ACCESSORIES

## WIRE SHELF

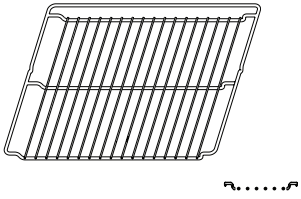

Use to cook food or as a support for pans, cake tins and other ovenproof items of cookware.

## DRIP TRAY

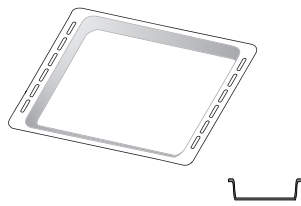

Use as an oven tray for cooking meat, fish, vegetables, focaccia, etc. or position underneath the wire shelf to collect cooking juices.

## BAKING TRAY \*

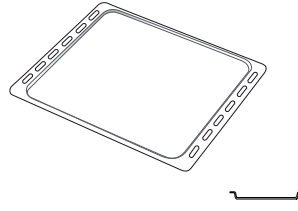

Use for cooking all bread and pastry products, but also for roasts, fish en papillote, etc.

## SLIDING RUNNERS \*

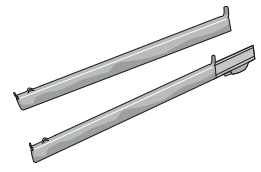

To facilitate inserting or removing accessories.

## AIR FRY TRAY \*

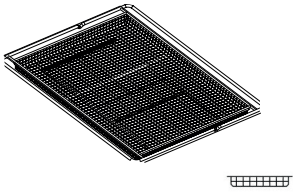

To be used when cooking foods with Air Fry function, with a baking tray positioned at a lower level to collect possible crumbs and drip. It can be cleaned in the dishwasher.

The number and the type of accessories may vary depending on which model is purchased.

Other accessories can be purchased separately; for orders and information contact the after sales service.

\* Available only in certain models

## INSERTING THE WIRE SHELF AND OTHER ACCESSORIES

Insert the wire shelf horizontally by sliding it across the shelf guides, making sure that the side with the raised edge is facing upwards.

Other accessories, such as the drip tray and the baking tray, are inserted horizontally in the same way as the wire shelf.

## REMOVING AND REFITTING THE SHELF GUIDES

- To remove the shelf guides, lift them up and pull the lower parts out of their lodgings: The shelf guides can now be removed.

- To refit the shelf guides, first fit them back into their upper seating. Keeping them held up, slide them into the cooking compartment, then lower them into position in the lower seating.

## FITTING THE SLIDING RUNNERS (IF PRESENT)

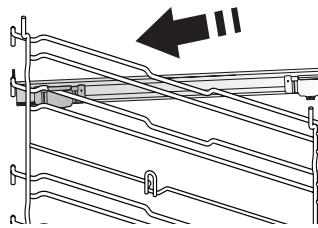

Remove the shelf guides from the oven and remove the protective plastic from the sliding runners.

Fasten the upper clip of the runner to the shelf guide and slide it along as far as it will go. Lower the other clip into position.

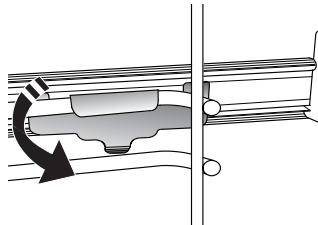

To secure the guide, press the lower portion of the clip firmly against the shelf guide. Make sure that the runners can move freely. Repeat these steps on the other shelf guide on the same level.

Please note: The sliding runners can be fitted on any level.

# FUNCTIONS

## 6TH SENSE

These allow a fully automatic cooking for all types of food (Lasagna, Meat, Fish, Vegetables, Cakes & Pastries, Salt cakes, Bread, Pizza). To get the best from this function, follow the indications on the relative cooking table.

-  **STEAM+**

The Steam+ function allows to obtain excellent performances thanks to the presence of steam in the cooking cycle. This function suggests the ideal temperature for cooking a wide range of recipes; the cooking times of the main dishes are shown in the relative cooking table. Always activate the steam function when the oven is cold, and after pouring drinking water into the bottom of the cavity.

-  **CASSEROLE**

This function suggests the best temperature and cooking method for pasta dishes.

-  **MEAT**

This function suggests the best temperature and cooking method for meat.

-  **BREAD**

This function automatically suggests the best temperature and cooking method for all types of bread.

-  **PIZZA**

This function allows you to cook great homemade pizza, in less than 10 minutes like in a restaurant. The dedicated cooking cycle works at temperature level above 300 degree Celsius, delivering pizza soft inside, crunchy on the edges and with a perfectly even browning.

Combining this function with the Pizza Stone WPro accessory and preheating for 30 minutes can bake a pizza in 5-8 min. (For orders and information contact the after sales service or [www.whirlpool.eu](http://www.whirlpool.eu).)

-  **PASTRY**

This function suggests the best temperature and cooking method for all types of cake.

## CONVENTIONAL

For cooking any kind of dish on one shelf only.

## GRILL

For grilling steaks, kebabs and sausages, cooking vegetables au gratin or toasting bread. When grilling meat, we recommend using a drip tray to collect the cooking juices: Position the tray on any of the levels below the wire shelf and add 500 ml of drinking water.

## FORCED AIR

For cooking different foods that require the same

cooking temperature on several shelves (maximum three) at the same time. This function can be used to cook different foods without odours being transferred from one food to another.

## CONVECTION BAKE

For cooking meat, baking cakes with fillings on one shelf only.

## SPECIAL FUNCTIONS

- **FAST PREHEAT**

For preheating the oven quickly.

- **TURBO GRILL**

For roasting large joints of meat (legs, roast beef, chicken). We recommend using a drip tray to collect the cooking juices: Position the pan on any of the levels below the wire shelf and add 500 ml of drinking water.

- **ECO CYCLE**

For cooking stuffed roasting joints and fillets of meat on a single shelf. When this Eco Cycle is in use, the light will remain switched off during cooking. To use the Eco Cycle and therefore optimise power consumption, the oven door should not be opened until the food is completely cooked.

- **AIR FRY/ CONVECT ROAST**

Using dedicated air fry tray (provided with some models) allows you to cook French fries, chicken nuggets and more using less oil, resulting pleasantly crispy. Heating elements cycle to properly heat the cavity, while the fan circulates hot air. Position the food on the Air Fry tray in a single layer and follow Air Fry Cooking Table instructions for best performances.

Alternatively, this function can be used to get great roasting results on meat and poultry, potatoes and vegetables, according to the cooking table recommendation. These recipes can be prepared using standard baking tray.

- **RISING**

For optimal proving of sweet or savoury dough. To maintain the quality of proving, do not activate the function if the oven is still hot following a cooking cycle.

- **SMART CLEAN**

The action of the steam released during this special low-temperature cleaning cycle allows dirt and food residues to be removed with ease. Pour 200 ml of drinking water on the bottom of the oven and only activate the function when the oven is cold.

# FIRST TIME USE

## 1. SET THE TIME

You will need to set the time when you switch on the oven for the first time.



The two digits for the hour will start flashing: Turn the knob to set the hour and press to confirm.



The two digits for the minutes will start flashing. Turn the knob to set the minutes and press to confirm.

Please note: To change the time at a later point, press and hold for at least one second while the oven is off and repeat the steps above.

You may need to set the time again following lengthy power outages.

## 2. SETTINGS

If required, you can change the default rated current (16 A).



Turn the selection knob to select the rated current, then press to confirm.

Please note: The oven is programmed to consume a level of electrical power that is compatible with a domestic network

that has a rating of more than 3 kW (16 A): If your household uses a lower power, you will need to decrease this value (13 A). Please note: To change the rated current at a later point, press and hold for at least five seconds while the oven is off and repeat the steps above.

## 3. HEAT THE OVEN

A new oven may release odours that have been left behind during manufacturing: This is completely normal.

Before starting to cook food, we therefore recommend heating the oven with it empty in order to remove any possible odours. Remove any protective cardboard or transparent film from the oven and remove any accessories from inside it. Heat the oven to 200 °C for around one hour, ideally using a function with air circulation (e.g. "Forced Air" or "Convection Bake").

Follow the instructions for setting the function correctly.

Please note: It is advisable to air the room after using the appliance for the first time.

# DAILY USE

## 1. SELECT A FUNCTION

When the oven is off, only the time is shown on the display. Press and hold to switch the oven on. Turn the rotary knob to view the main functions available on the left-hand display. Select one and press .



To select a sub-function (where available), select the main function and then press to confirm and go to the function menu.



Turn the rotary knob to select from amongst the subfunctions available on the right-hand display and then press to confirm.

## 2. SET THE FUNCTION

After having selected the function you require, you can change its settings. The display will show the settings that can be changed in sequence.

### TEMPERATURE / GRILL LEVEL



When the °C icon flashes on the display, turn the knob to change the value, then press to confirm and continue to alter the settings that follow (if possible).

You can also set the grill level (3 = high, 2 = medium, 1 = low) at the same time.



Please note: Once the function has started, you can change the temperature or the grill level by pressing or by turning the knob directly.

#### DURATION



When the icon flashes on the display, use the adjustment knob to set the cooking time you require and then press to confirm.

You do not have to set the cooking time if you want to manage cooking manually: Press to confirm and start the function. In this case, you cannot set the end cooking time by programming a delayed start.

Please note: You can adjust the cooking time that has been set during cooking by pressing : Turn the knob to change the hour and press to confirm.

#### SETTING THE END COOKING TIME/DELAYED START

In many functions, once you have set a cooking time you can delay starting the function by programming its end time. Where you can change the end time, the display will show the time the function is expected to finish while the icon flashes.



If necessary, turn the knob to set the time you want cooking to end, then press to confirm and start the function.

Place the food in the oven and close the door: The function will start automatically after the period of time that has been calculated in order for cooking to finish at the time you have set.



Please note: Programming a delayed cooking start time will disable the oven preheating phase: The oven will reach the temperature you require gradually, meaning that cooking times will be slightly longer than those listed in the cooking table.

During the waiting time, you can use the knob to change the programmed end time.

Press or to change the temperature and cooking time settings. Press to confirm when finished.

#### 3. ACTIVATE THE FUNCTION

Once you have applied the settings you require, press to activate the function.

You can press and hold at any time to pause the function that is currently active.

#### 4. PREHEATING

Some functions have an oven preheating phase: Once the function has started, the display indicates that the preheating phase has been activated.



Once this phase has finished, an audible signal will sound and the display will indicate that the oven has reached the set temperature.



At this point, open the door, place the food in the oven, close the door and start cooking by pressing .

Please note: Placing the food in the oven before preheating has finished may have an adverse effect on the final cooking result.

Opening the door during the preheating phase will stop pause it.

The cooking time does not include a preheating phase.

You can always change the temperature you want the oven to reach using the knob.

#### 5. END OF COOKING

An audible signal will sound and the display will indicate that cooking is complete.



To extend the cooking time without changing the settings, turn the knob to set a new cooking time and press .

#### 6. 6<sup>TH</sup> SENSE FUNCTIONS

##### SMART CLEAN

To activate the "Smart Clean" function, with the oven cold, distribute 200 ml of water on the bottom of the oven cavity, then close the oven door.

Access special functions and turn the knob to select from menu. then press to confirm.

Press to start immediately the cleaning cycle, or press to set the end time/start delayed.

At the end of the cycle, let the oven cooling down and remove any residual water in the oven and start cleaning using a sponge moistened with hot water (cleaning could be compromised if delayed by more than 15 minutes).

Please note: The duration and temperature of cleaning cycle cannot be set.

---

## 7. KEYLOCK

To lock the keypad, press and hold << for at least five seconds.



Do this again to unlock the keypad.

Please note: This function can also be activated during cooking. For safety reasons, the oven can be switched off at any time by pressing .

## . NOTES

- Do not cover the inside of the oven with aluminium foil.
- Never drag pots or pans across the bottom of the oven as this could damage the enamel coating.
- Do not place heavy weights on the door and do not hold on to the door.
- Due to the higher temperature of the Pizza cycle it is expected to experience slightly higher cooling fan noise.

---

## USEFUL TIPS

---

### HOW TO READ THE COOKING TABLE

The table lists the best function, accessories and level to use to cook different types of food. Cooking times start from the moment food is placed in the oven, excluding preheating (where required). Cooking temperatures and times are approximate and depend on the amount of food and the type of accessory used. Use the lowest recommended settings to begin with and, if the food is not cooked enough, then switch to higher settings. Use the accessories supplied and preferably dark-coloured metal cake tins and baking trays. You can also use Pyrex or stoneware pans and accessories, but bear in mind that cooking times will be slightly longer.

---

### COOKING DIFFERENT FOODS AT THE SAME TIME

Using the "Forced Air" function, you can cook different foods which require the same cooking temperature at the same time (for example: fish and vegetables), using different shelves. Remove the food which requires a shorter cooking time and leave the food which requires a longer cooking time in the oven.

---

### MEAT

Use any kind of oven tray or pyrex dish suited to the size of the piece of meat being cooked. For roast joints, it is best to add some stock to the bottom of the dish, basting the meat during cooking for added flavour. Please note that steam will be generated during this operation. When the roast is ready, let it rest in the oven for another 10-15 minutes, or wrap it in aluminium foil.

When you want to grill meat, choose cuts with an even thickness all over in order to achieve uniform cooking results. Very thick pieces of meat require longer cooking times. To prevent the meat from burning on the outside, lower the position of the wire shelf, keeping the food farther away from the grill. Turn the meat two thirds of the way through cooking. Take care when opening the door as steam will escape.

To collect the cooking juices, we recommend placing a dripping pan filled with half a litre of drinking water directly underneath the wire shelf on which the food is placed. Top-up when necessary.

### DESSERTS

Cook delicate desserts with the conventional function on one shelf only.

Use dark-coloured metal baking pans and always place them on the wire shelf supplied. To cook on more than one shelf, select the forced air function and stagger the position of the cake tins on the shelves, aiding optimum circulation of the hot air.

To check whether a leavened cake is cooked, insert a wooden toothpick into the centre of the cake. If the toothpick comes out clean, the cake is ready.

If using non-stick baking pans, do not butter the edges as the cake may not rise evenly around the edges.

If the item "swells" during baking, use a lower temperature next time and consider reducing the amount of liquid you add or stirring the mixture more gently.

For desserts with moist fillings or toppings (such as cheesecake or fruit tarts), use the "Convection bake" function. If the base of the cake is soggy, lower the shelf and sprinkle the bottom of the cake with breadcrumbs or biscuit crumbs before adding the filling.

---

### RISING

It is always best to cover the dough with a damp cloth before placing it in the oven. Dough proving time with this function is reduced by approximately one third compared to proving at room temperature (20-25°C). The rising time for pizza starts at around one hour for 1 kg of dough.



# AIR FRY COOKING TABLE

	RECIPE	FUNCTION	SUGGESTED QUANTITY	PREHEAT	TEMPERATURE (°C)	DURATION (MIN.)	SHELF AND ACCESSORIES
FROZEN FOOD	Frozen French Fries		650 - 850g	Yes	200	25 - 30	4  2
	Frozen Chicken Nugget		500g	Yes	200	15 - 20	4  2
	Fish Sticks		500g	Yes	220	15 - 20	4  2
	Onion Rings		500g	Yes	200	15 - 20	4  2
VEGETABLES	Fresh Breaded Zucchini		400g	Yes	200	15 - 20	4  2
	Homemade Fries		300 - 800 g	Yes	200	20 - 40	4  2
	Mixed Vegetables		300 - 800 g	Yes	200	20 - 30	4  2
MEAT AND FISH	Chicken Breasts		1 - 4 cm	Yes	200	20 - 40	4  2
	Chicken Wings		200 - 1500 g	Yes	220	30 - 50	4  2
	Breaded Cutlet		1 - 4 cm	Yes	220	20 - 50	4  2
	Fish Fillet		1 - 4 cm	Yes	220	15 - 25	4  2

For cooking fresh or homemade foods, spread a thin layer of oil across the food surface.  
In order to guarantee uniform cooking results, mix food halfway through the recommended cooking time.

FUNCTIONS	 Air Fry		
ACCESSORIES	 Air Fry tray	 Oven tray or cake tray on wire shelf	 Drip tray / Baking tray or oven tray on wire shelf



# COOKING TABLE

RECIPE	FUNCTION	PREHEAT	TEMPERATURE (°C)	COOK TIME (Min.)	LEVEL AND ACCESSORIES
Leavened cakes / Sponge cakes		-	170	30 - 50	2 
		Yes	160	30 - 50	2 
		Yes	160	30 - 50	4 1 
Filled cakes (cheesecake, strudel, apple pie)		-	160 - 200	30 - 85	3 
		Yes	160 - 200	35 - 90	4 1 
Cookies / Small cakes		-	160 - 170	20 - 40	3 
		Yes	150 - 160	20 - 40	4 
		Yes	150 - 160	20 - 40	4 1 
		Yes	135	50 - 90	5 4 3 1 
Tarts		Yes	170	50 - 80	5 4 3 1 
Choux buns		-	180 - 200	30 - 40	3 
		Yes	180 - 190	35 - 45	4 1 
		Yes	180 - 190	35 - 45*	5 3 1 
Meringues		Yes	90	110 - 150	3 
		Yes	90	130 - 150	4 1 
		Yes	90	140 - 160*	5 3 1 
Pizza (Thin, thick, focaccia)		Yes	310	7-12	2 
		Yes	220 - 240	20 - 40	4 1 
		Yes	220 - 240	25 - 50*	5 3 1 
		Yes	210	40 - 60	5 4 3 1 
Bread loaf 0,5 kg		-	180 - 220	50 - 70	2 
Small bread		-	180 - 220	30 - 50	3 
Bread		Yes	180 - 220	30 - 60	4 1 
Frozen pizza		Yes	250	10 - 15	2 
		Yes	250	10 - 20	4 1 
Savoury pies (vegetable pie, quiche)		Yes	180 - 190	45 - 60	2 
		Yes	180 - 190	45 - 60	4 1 
		Yes	180 - 190	45 - 70*	5 3 1 

FUNCTIONS	Conventional	Grill	Turbo Grill	Forced Air	Convect Bake	ECO	Air Fry
AUTOMATIC FUNCTIONS	Casserole	Meat	Bread	Pizza function	Pastry		
ACCESSORIES	Wire shelf	Oven tray or cake tray on wire shelf	Drip tray / Baking tray or oven tray on wire shelf	Drip tray / Baking tray	Drip tray with 500 ml of water		

RECIPE	FUNCTION	PREHEAT	TEMPERATURE (°C)	COOK TIME (Min.)	LEVEL AND ACCESSORIES
Vols-au-vent / Puff pastry crackers		Yes	190 - 200	20 - 30	3
		Yes	180 - 190	20 - 40	4 1
		Yes	180 - 190	20 - 40*	5 3 1
Lasagne / Flans		-	190 - 200	40 - 80	3
Baked pasta / Cannelloni		-	190 - 200	25 - 60	3
Lamb / Veal / Beef / Pork 1 kg		-	190 - 200	60 - 90	3
Chicken / Rabbit / Duck 1 kg		-	200 - 230	50 - 80 **	3
Turkey / Goose 3 kg		-	190 - 200	90 - 150	2
Baked fish / en papillote (fillets, whole)		Yes	180 - 200	40 - 60	3
Stuffed vegetables (tomatoes, courgettes, aubergines)		Yes	180 - 200	50 - 60	2
Toast		-	3 (High)	3 - 6	5
Fish fillets / Steaks		-	2 (Mid)	20 - 30***	4 3
Sausages / Kebabs / Spare ribs / Hamburgers		Yes	200 - 220	15 - 30***	5 4
Roast chicken 1-1.3 kg		Yes	200 - 220	55 - 70**	2 1
Roast beef rare 1 kg		-	2 (Mid)	35 - 50**	3
Leg of lamb / Shanks		-	2 (Mid)	60 - 90**	3
Roast potatoes		Yes	200 - 220	35 - 55**	3
Vegetable gratin		Yes	200 - 220	10 - 25	3
Complete meal: Fruit tart (level 5) / lasagna (level 3) / meat (level 1)		Yes	190	40 - 120*	5 3 1
Complete meal: Fruit tart (level 5) / roasted vegetables (level 4) / lasagna (level 2) / cuts of meat (level 1)		Yes	190	40 - 120*	5 4 2 1
Lasagna & Meat		Yes	200	50 - 120*	4 1
Meat & Potatoes		Yes	200	45 - 120*	4 1
Fish & Vegetables		Yes	180	30 - 50	4 1
Stuffed roasting joints	ECO	-	200	80 - 120*	3
Cuts of meat (rabbit, chicken, lamb)	ECO	-	200	50 - 120*	3

\* Estimated length of time: dishes can be removed from the oven at different times depending on personal preference.





















\*\* Turn food two thirds of the way through cooking (if necessary).

\*\*\* Turn food halfway through cooking.



FUNCTIONS						ECO	
	Conventional	Grill	Turbo Grill	Forced Air	Convect Bake	ECO	Air Fry
AUTOMATIC FUNCTIONS							
	Casserole	Meat	Bread	Pizza function	Pastry		
ACCESSORIES							
	Wire shelf	Oven tray or cake tray on wire shelf	Drip tray / Baking tray or oven tray on wire shelf	Drip tray / Baking tray	Drip tray / Baking tray		Drip tray with 500 ml of water



# STEAM+ COOKING TABLE

FOOD	RECIPE	QUANTITY	TIME (MIN.)	ACCESSORIES	WATER
BREAD	Small breads	80-100 g	30 - 45		100 ml
	Sandwich loaf in tin	300-500 g	40 - 60		
	Bread	500g-2 kg	50 - 100		
	Baguettes	200-300 g	30 - 45		
PASTRIES	Cookies	one tray	25 - 35		
	Muffin	30-60 g	25 - 45		
	Sponge Cake	500-700 g	30 - 50		
	Tart	one tray	35 - 55		
MEAT	Roast	1 kg	60 - 110		200 ml
	Ribs	500g-1,5 kg	50 - 75		
	Chicken	1-1,5 kg	55 - 80		
	Chicken/Turkey	3 kg	100 - 140		
FISH	Fillet Steak	0.5-2 cm	15 - 25		
	Fillet Steak	2-4 cm	20 - 35		
	Whole Fish	300- 600 g	20 - 30		
	Whole Fish	600 -1200 g	25 - 45		
VEGETABLES	Roasted Potatoes	0.5-1.5 kg	45 - 60		
	Stuffed Peppers	1-2 kg	35 - 55		
	Roasted Broccoli	0.3-1 kg	30 - 50		
	Roasted Zucchini	0.5-1.5 kg	30 - 50		

Start the STEAM+ function only when the oven is cold. Opening the door and topping up the water during cooking may have an adverse effect on the final cooking result.

ACCESSORIES			
	Air Fry tray	Oven tray or cake tray on wire shelf	Drip tray / Baking tray or oven tray on wire shelf

# MAINTENANCE AND CLEANING

**Make sure that the oven has cooled down before carrying out any maintenance or cleaning.**

**Do not use steam cleaners.**

**Do not use wire wool, abrasive scourers or abrasive/corrosive cleaning agents, as these could damage the surfaces of the appliance.**

**Wear protective gloves.**

**The oven must be disconnected from the mains before carrying out any kind of maintenance work.**

## EXTERIOR SURFACES

- Clean the surfaces with a damp microfibre cloth. If they are very dirty, add a few drops of pH-neutral detergent. Finish off with a dry cloth.
- Do not use corrosive or abrasive detergents. If any of these products inadvertently comes into contact with the surfaces of the appliance, clean immediately with a damp microfibre cloth.

## INTERIOR SURFACES

- After every use, leave the oven to cool and then clean it, preferably while it is still warm, to remove any deposits or stains caused by food residues. To dry any condensation that has formed as a result of cooking foods with a high water content, leave the oven to cool completely and then wipe it with a cloth or sponge.

- Activate the "Smart Clean" function for optimum cleaning of the internal surfaces. (Only in some models).
- Clean the glass in the door with a suitable liquid detergent.
- The oven door can be removed to facilitate cleaning.

## ACCESSORIES

Soak the accessories in a washing-up liquid solution after use, handling them with oven gloves if they are still hot. Food residues can be removed using a washing-up brush or a sponge. Do not clean Food Probe and Meat Probe (if present) in the dishwasher. Air Fry tray (if present) can be cleaned in the dishwasher.

## CLEANING THE CATALYTIC PANELS

(ONLY IN SOME MODELS)

This oven is equipped with special catalytic panels that facilitate cleaning of the cooking compartment thanks to their special self-cleaning coating, which is highly porous and able to absorb grease and grime. These panels are fitted to the shelf guides: When repositioning and then refitting the shelf guides, make sure that the hooks at the top are slotted into the appropriate holes in the panels.

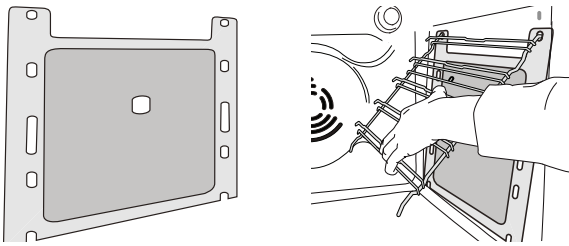

To make best use of the catalytic panels' self-cleaning properties, we recommend heating the oven to 200 °C for around one hour using the "Convection Bake" function. The oven must be empty during this time. Then leave the appliance to cool down before removing any remaining food residues using a nonabrasive sponge.

Please note: Using corrosive or abrasive cleaning agents, stiff brushes, pan scourers or oven sprays could damage the catalytic surface and compromise its self-cleaning properties.

Please contact our After-sales Service if you require replacement panels.

## REPLACING THE LAMP

For the replacement of the lamp, contact the after sales service.

## REMOVING AND REFITTING THE DOOR

**1.** To remove the door, open it fully and lower the catches until they are in the unlock position.

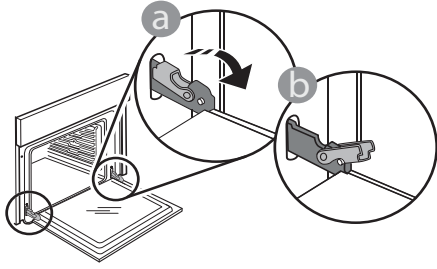

**2.** Close the door as much as you can. Take a firm hold of the door with both hands – do not hold it by the handle.

Simply remove the door by continuing to close it while pulling it upwards at the same time until it is released from its seating. Put the door to one side, resting it on a soft surface.

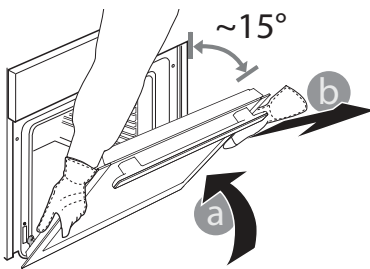

**3.** Refit the door by moving it towards the oven, aligning the hooks of the hinges with their seating and securing the upper part onto its seating.

**4.** Lower the door and then open it fully. Lower the catches into their original position: Make sure that you lower them down completely.

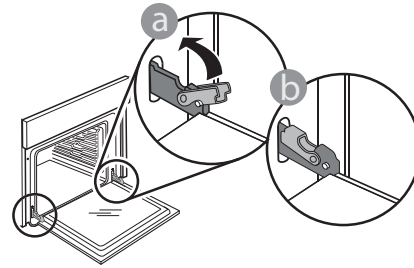

Apply gentle pressure to check that the catches are in the correct position.

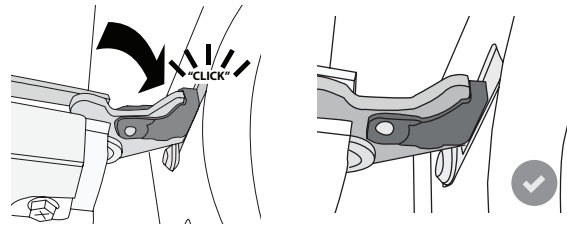

**5.** Try closing the door and check to make sure that it lines up with the control panel. If it does not, repeat the steps above: The door could become damaged if it does not work properly.

## LOWER THE TOP HEATING ELEMENT

(ONLY IN SOME MODELS)

**1.** Remove the lateral shelf guides.

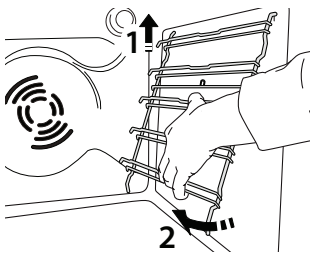

**2.** Pull the heating element out a little and lower it.

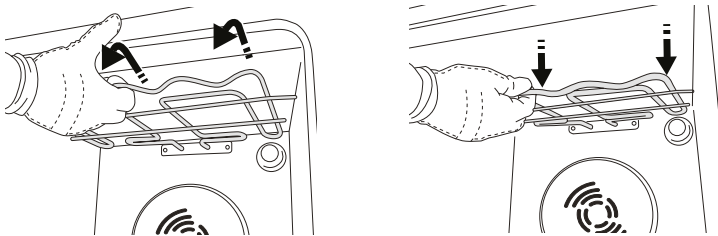

**3.** To reposition the heating element, lift it up, pulling it slightly towards you, making sure it comes to rest on the lateral supports.

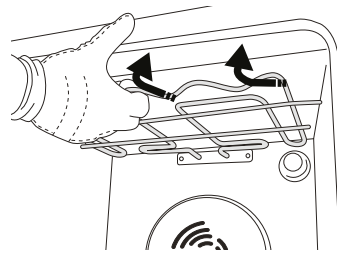

# TROUBLESHOOTING

Problem	Possible cause	Solution
The oven is not working.	Power cut. Disconnection from the mains.	Check for the presence of mains electrical power and whether the oven is connected to the electricity supply. Turn off the oven and restart it to see if the fault persists.
The display shows the letter "F" followed by a number.	Software problem.	Contact the Call Center and state the number following the letter "F".
The display shows unclear text and appears to be broken.	Another language set.	Contact the Call Center.
Cooking cycle with probe ended without evident cause or error F3E3 is printed on the screen.	Food Probe is not properly connected.	Check connection of the food probe.

**Policies, standard documentation and additional product information can be found by:**

- Using the QR on your product
- Visiting our website **[docs.bauknecht.eu](https://docs.bauknecht.eu)**
- Alternatively, **contact our After-sales Service** (See phone number in the warranty booklet). When contacting our After-sales Service, please state the codes provided on your product's identification plate.

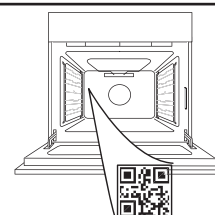



**GRAZIE PER AVERE ACQUISTATO UN PRODOTTO WHIRLPOOL**

Per ricevere un'assistenza più completa, registrare il prodotto su [www.whirlpool.eu/register](http://www.whirlpool.eu/register)

**SCANSIONARE IL CODICE QR SUL PROPRIO APPARECCHIO PER OTTENERE MAGGIORI INFORMAZIONI**

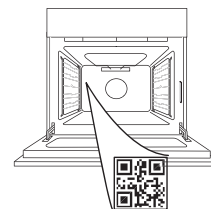

Prima di utilizzare l'apparecchio leggere attentamente le istruzioni di sicurezza.

## DESCRIZIONE DEL PRODOTTO

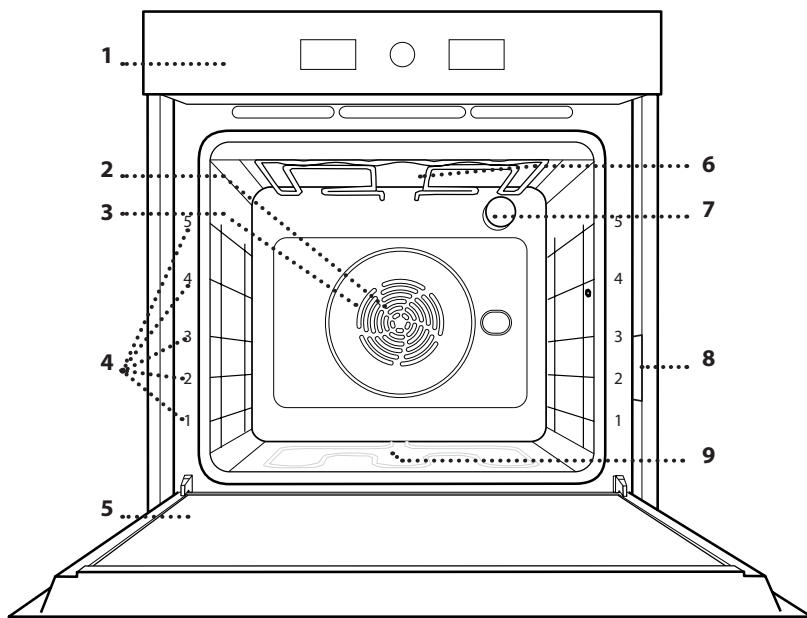

1. Pannello comandi
2. Ventola
3. Resistenza circolare (non visibile)
4. Griglie laterali (il livello è indicato sulla parte frontale del forno)
5. Porta
6. Resistenza superiore / grill
7. Luce
8. Targhetta matricola (da non rimuovere)
9. Resistenza inferiore (non visibile)

## PANNELLO COMANDI

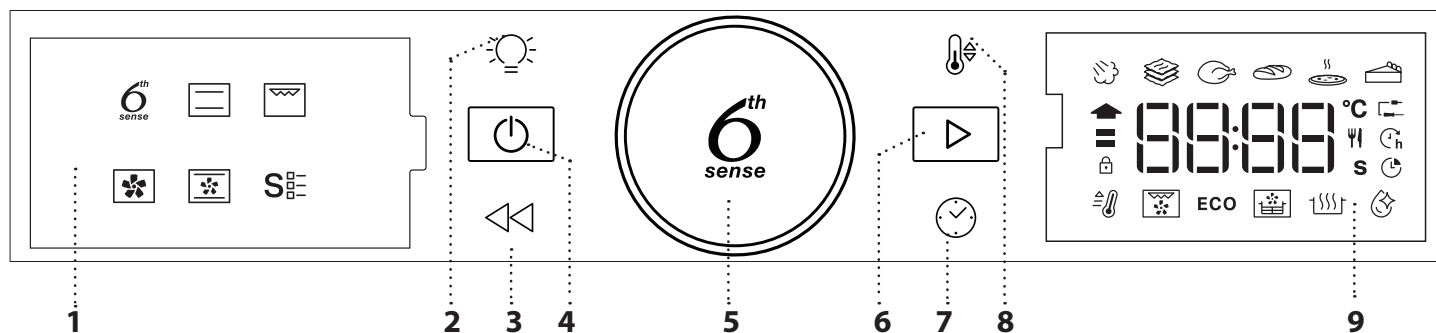

### 1. PARTE SINISTRA DEL DISPLAY

#### 2. LAMPADA

Per accendere/spegnere la lampadina.

#### 3. INDIETRO

Per tornare alla schermata precedente. Durante la cottura, permette di modificare le impostazioni.

#### 4. ON/OFF

Per accendere e spegnere il forno o terminare in qualunque momento una funzione attiva.

### 5. MANOPOLA ROTANTE

Ruotando la manopola è possibile spostarsi tra le funzioni e regolare i parametri di cottura. Premere per selezionare, impostare, visualizzare e confermare le funzioni o i parametri e per avviare i programmi di cottura.

### 6. AVVIO

Per avviare le funzioni e confermare le impostazioni o un valore impostato.

### 7. TEMPO

Per impostare l'ora e per regolare il tempo di cottura.

### 8. TEMPERATURA

Per impostare la temperatura.

### 9. DISPLAY DESTRA

# ACCESSORI

## GRIGLIA

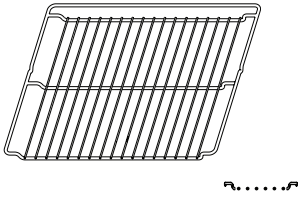

Utilizzare per cuocere gli alimenti o come supporto per teglie, tortiere e altre pentole da forno.

## LECCARDA

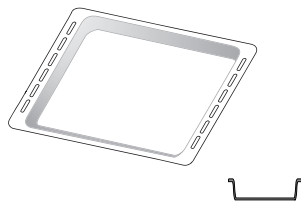

Utilizzare come teglia da forno per cucinare carne, pesce, verdure, focacce, ecc. o posizionare sotto la griglia per raccogliere i succhi di cottura.

## PIASTRA DOLCI \*

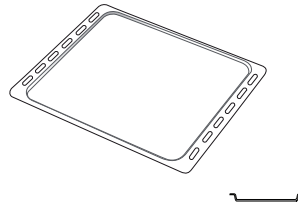

Utilizzare per la cottura di tutti i prodotti di panetteria e pasticceria, ma anche per arrostiti, pesce en papillote, ecc.

## GUIDE DI SCORRIMENTO \*

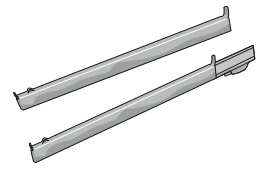

Per facilitare l'inserimento o la rimozione degli accessori.

## LECCARDA FRITTURA AD ARIA \*

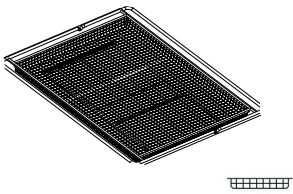

Da utilizzare quando si cucinano alimenti con la funzione Frittura ad aria, con una teglia posizionata a un livello inferiore per raccogliere eventuali briciole e sgocciolamenti. Può essere lavata in lavastoviglie.

Il numero e il tipo di accessori possono variare a seconda del modello acquistato. Altri accessori possono essere acquistati separatamente; per ordini e informazioni contattare il servizio assistenza clienti.

\* Disponibile solo in alcuni modelli

## INSERIRE LA GRIGLIA E GLI ALTRI ACCESSORI

Inserire la griglia orizzontalmente facendola scivolare sulle griglie laterali inserendo dapprima il lato rialzato orientato verso l'alto.

Gli altri accessori, come la leccarda o la teglia, si inseriscono orizzontalmente come la griglia.

## TOGLIERE E RIMONTARE LE GRIGLIE LATERALI

- Per togliere le griglie, sollevare le griglie prima di scostare la parte inferiore dalle proprie sedi: a questo punto è possibile rimuovere le griglie.
- Per rimontare le griglie, inserirle dapprima nelle sedi superiori. Avvicinarle alla cavità tenendo sollevato, quindi abbassarle in posizione nelle sedi inferiori.

## MONTAGGIO DELLE GUIDE SCORREVOLI (SE PRESENTE)

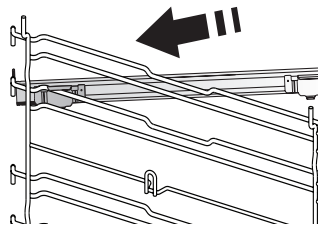

Togliere dal forno le griglie laterali e rimuovere la protezione in plastica dalle guide scorrevoli.

Ancorare alla griglia laterale la clip superiore della guida e farla scivolare fino a fine corsa. Abbassare l'altra clip in posizione.

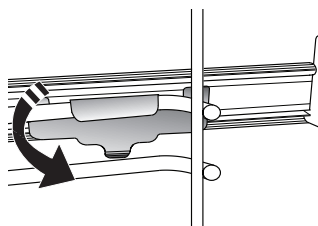

Per fissare la guida, premere la parte inferiore della clip contro la griglia laterale. Assicurarsi che le guide possano scorrere liberamente. Ripetere questa operazione sull'altra griglia laterale, allo stesso livello.

Note: le guide scorrevoli possono essere montate a qualsiasi livello.



# FUNZIONI

## 6TH SENSE

Questa funzione permette la cottura completamente automatica di tutte le pietanze (lasagna, carne, pesce, verdure, torte & dolci, torte salate, pane, pizza). Per utilizzare al meglio questa funzione si raccomanda di seguire le indicazioni della tabella di cottura.

-  **VAPORE+**

La funzione Vapore+ permette di ottenere ottime prestazioni grazie alla presenza di vapore nel ciclo di cottura. Questa funzione suggerisce la temperatura ideale per la cottura di un'ampia gamma di ricette; i tempi di cottura dei piatti principali sono indicati nella relativa tabella di cottura. Attivare sempre la funzione vapore quando il forno è freddo e dopo aver versato acqua potabile sul fondo della cavità.

-  **PRIMI PIATTI**

Questa funzione suggerisce la migliore temperatura e modalità di cottura per le pietanze a base di pasta.

-  **CARNE**

Questa funzione suggerisce la migliore temperatura e modalità di cottura per la carne.

-  **PANE**

Questa funzione suggerisce automaticamente la migliore temperatura e modalità di cottura per qualsiasi tipo di pane.

-  **PIZZA**

Questa funzione consente di cucinare un'ottima pizza fatta in casa, in meno di 10 minuti come al ristorante. Il ciclo di cottura dedicato funziona a temperature superiori a 300 gradi Celsius, garantendo una pizza morbida all'interno, croccante sui bordi e con una doratura perfettamente uniforme.

Combinando questa funzione con l'accessorio Pizza Stone WPro e preriscaldando per 30 minuti, può cuocere una pizza in 5-8 minuti (per ordini e informazioni, contattare il servizio assistenza clienti o [www.whirlpool.eu](http://www.whirlpool.eu).)

-  **TORTE E DOLCI**

Questa funzione suggerisce la migliore temperatura e modalità di cottura per qualsiasi tipo di torta.

## STATICO

Per cuocere qualsiasi tipo di pietanza su un solo ripiano.

## GRILL

Per grigliare bistecche, spiedini e salsicce, cucinare verdure gratinate o tostare il pane. Per la grigliatura delle carni, si consiglia di utilizzare una leccarda per raccogliere il liquido di cottura: posizionare la leccarda a un livello sotto la griglia e aggiungere 500 ml di acqua potabile.

## TERMOVENTILATO

Per cuocere contemporaneamente su più ripiani (massimo tre) alimenti diversi che richiedono la medesima temperatura di cottura. La funzione permette di cuocere senza trasmissione di odori da un alimento all'altro.

## VENTILATO

Per cuocere carni o torte ripiene su un solo ripiano.

## FUNZIONI SPECIALI

- **PRERISC RAPIDO**

Per preriscaldare rapidamente il forno.

- **TURBO GRILL**

Per arrostiti grandi tagli di carne (cosce, roast beef, pollo). Si consiglia di utilizzare una leccarda per raccogliere il liquido di cottura: posizionarla a un livello sotto la griglia e aggiungere 500 ml di acqua potabile.

- **CICLO ECO**

Per cuocere arrostiti ripieni e filetti di carne in pezzi su un solo ripiano. Quando questo Ciclo Eco è in uso, la spia rimarrà spenta durante la cottura. Per utilizzare il Ciclo Eco e quindi ottimizzare il consumo di energia, la porta del forno non deve essere aperta finché gli alimenti non sono completamente cotti.

- **AIR FRY/CONVECT ROAST**

La leccarda Frittura ad aria dedicata (fornita con alcuni modelli) consente di cuocere patate fritte, bocconcini di pollo e altro ancora utilizzando meno olio, ottenendo un risultato piacevolmente croccante. Gli elementi riscaldanti si attivano per riscaldare adeguatamente la cavità, mentre la ventola fa circolare l'aria calda. Posizionare gli alimenti sulla leccarda Air Fry in un unico strato e seguire le istruzioni della tabella di cottura Air Fry per ottenere le migliori prestazioni.

In alternativa, questa funzione può essere utilizzata per ottenere ottimi risultati di arrostitimento di carne e pollame, patate e verdure, secondo le raccomandazioni della tabella di cottura. Queste ricette possono essere preparate con una teglia standard.

- **LIEVITAZIONE**

Per ottenere una lievitazione ottimale di impasti dolci o salati. Allo scopo di preservare la qualità della lievitazione, non attivare la funzione se il forno è ancora caldo dopo un ciclo di cottura.

- **SMART CLEAN**

L'azione del vapore rilasciato durante questo speciale ciclo di pulizia a bassa temperatura permette di rimuovere facilmente sporco e residui di cibo. Versare 200 ml di acqua potabile sul fondo del forno, attivando la funzione a forno freddo.

# PRIMO UTILIZZO

## 1. IMPOSTARE L'ORA

Alla prima accensione è necessario impostare l'ora.



Sul display lampeggiano le due cifre relative alle ore: Ruotare la manopola per impostare l'ora e premere  per confermare.



Sul display lampeggiano le due cifre relative ai minuti. Ruotare la manopola per impostare i minuti e premere  per confermare.

Note: per modificare successivamente l'ora, premere  per almeno 1 secondo a forno spento e ripetere le operazioni sopra descritte.

dopo una prolungata interruzione di corrente potrebbe essere necessario impostare nuovamente l'ora.

## 2. IMPOSTAZIONI

Se necessario, è possibile modificare la corrente nominale predefinita (16 A).



Ruotare la manopola per indicare l'assorbimento di potenza, quindi premere  per confermare.

Note: il forno è programmato per assorbire una potenza elettrica compatibile con una rete domestica di capacità superiore a 3 kW (16 A); nel caso si disponga di una potenza inferiore, è necessario diminuire il valore (13A).

Note: Per modificare la corrente nominale in un momento successivo, tenere premuto  per almeno cinque secondi a forno spento e ripetere i passaggi precedenti.

## 3. RISCALDAMENTO DEL FORNO

Un nuovo forno può rilasciare degli odori dovuti alla lavorazione di fabbrica: questo è normale.



Prima di cucinare gli alimenti è dunque raccomandato di riscaldare a vuoto il forno per rimuovere ogni odore. Rimuovere protezioni di cartone o pellicole trasparenti e togliere gli accessori dal forno. Riscaldare il forno a 200°C per circa un'ora utilizzando preferibilmente una funzione ventilata ("Termoventilato" o "Ventilato").

Seguire le istruzioni per impostare correttamente la funzione.

Note: si consiglia di arieggiare il locale dopo il primo utilizzo dell'apparecchio.

# USO QUOTIDIANO

## 1. SELEZIONARE UNA FUNZIONE

Quando il forno è spento, sul display viene visualizzata solo l'ora. tenere premuto  per accendere il forno. Ruotare la manopola girevole per visualizzare sul display sinistro le funzioni principali disponibili, e premere  per confermare.



Dove presente, per selezionare una sottofunzione, dopo aver selezionato la funzione principale, premere  per confermare e accedere al menu delle funzioni.

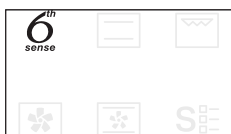

Ruotare la manopola girevole per scegliere tra le sottofunzioni disponibili nella parte destra del display e premere  per confermare.

## 2. IMPOSTARE LA FUNZIONE

Dopo avere selezionato la funzione desiderata è possibile modificarne le impostazioni. Il display mostra in sequenza le impostazioni che è possibile modificare.

### TEMPERATURE / GRILL LEVEL (TEMPERATURA / LIVELLO GRILL)



Quando l'icona °C lampeggia sul display, ruotare la manopola per modificare il valore, quindi premere  per confermare e procedere con le impostazioni seguenti, per tutti i valori che è possibile regolare. Allo stesso modo, è possibile impostare il livello del grill (3 alto, 2 medio, 1 basso).



Note: una volta attivata la funzione, sarà possibile modificare la temperatura o il livello del grill premendo o ruotando direttamente la manopola.

### DURATA



Quando l'icona lampeggia sul display, utilizzare la manopola per impostare il tempo di cottura desiderato, quindi premere per confermare.

È possibile non impostare la durata per gestire manualmente la cottura: Premere per confermare e avviare la funzione. In questo caso, non sarà possibile impostare l'ora di fine cottura, programmando l'avvio ritardato.

Note: durante la cottura, premendo è possibile regolare il tempo impostato: Ruotare la manopola per impostare l'ora e premere per confermare.

### IMPOSTARE L'ORA DI FINE COTTURA/ (AVVIO RITARDATO)

In molte funzioni, una volta impostato un tempo di cottura è possibile posticipare l'avvio della funzione programmando l'ora di fine cottura. Dove possibile modificare l'ora di fine, il display mostra l'ora di fine della funzione prevista mentre l'icona lampeggia.



Se necessario, ruotare la manopola per impostare l'ora di fine cottura desiderata, quindi premere per confermare, attivando la funzione.

Posizionare gli alimenti nel forno e chiudere la porta: la funzione si avvierà automaticamente dopo un periodo di tempo calcolato per terminare la cottura all'orario impostato.



Note: La programmazione dell'avvio ritardato di una cottura disattiva la fase di preriscaldamento del forno: la temperatura desiderata viene raggiunta gradualmente, quindi i tempi di cottura si allungheranno leggermente rispetto a quanto indicato nella tabella di cottura.

Durante il tempo di attesa, è possibile utilizzare la manopola per regolare l'ora di fine programmata.

Premere o per modificare i valori impostati per la temperatura e il tempo di cottura. una volta modificati, premere per confermare.

### 3. AVVIARE LA FUNZIONE

Una volta che i valori corrispondono a quelli

desiderati, premere per avviare la funzione.

Tenere premuto per interrompere in ogni momento la funzione attivata.

### 4. PRERISCALDAMENTO

In alcune funzioni, è prevista una fase di preriscaldamento del forno: una volta avviata la funzione, il display segnala che si è attivata la fase di preriscaldamento.



Al termine di questa fase, un segnale acustico e il display indicheranno che il forno ha raggiunto la temperatura impostata.



A questo punto, aprire la porta, inserire gli alimenti nel forno, chiudere la porta e procedere alla cottura premendo .

Note: inserire gli alimenti nel forno prima della fine del preriscaldamento può compromettere i risultati di cottura. Aprendo la porta durante la fase di preriscaldamento, questa si interrompe temporaneamente. Il tempo di cottura non comprende la fase di preriscaldamento.

È sempre possibile modificare la temperatura del forno che si desidera raggiungere utilizzando la manopola.

### 5. FINE COTTURA

Allo scadere del tempo programmato, un segnale acustico e il display indicheranno che la cottura è terminata.



Per prolungare la cottura mantenendo i valori impostati, ruotare la manopola per impostare un nuovo tempo di cottura e premere .

### 6. FUNZIONI 6<sup>TH</sup> SENSE

#### SMART CLEAN

Per attivare la funzione "Smart Clean", con il forno freddo distribuire 200 ml d'acqua sul fondo della cavità del forno, quindi chiudere la porta. Accedere alle funzioni speciali e ruotare la manopola per selezionare dal menu. Quindi premere per confermare. Premere per avviare immediatamente il ciclo di pulizia, oppure premere per impostare l'ora di fine/avvio ritardato.

Alla fine del ciclo, lasciare raffreddare il forno, rimuovere l'acqua residua e pulire con una spugna inumidita con acqua calda (la pulizia può risultare meno efficace se si aspetta per più di 15 minuti).

Note: non è possibile impostare la durata e la temperatura del ciclo di pulizia.

---

## 7. BLOCCO TASTI

Per bloccare il tastierino, tenere premuto <<< per almeno cinque secondi.



Ripetere la procedura per sbloccare il tastierino.

Note: questa funzione può essere attivata anche durante la cottura. Per ragioni di sicurezza, è possibile spegnere il forno in qualsiasi momento premendo [OFF].

### . NOTE

- Non coprire l'interno del forno con pellicola di alluminio.
- Non trascinare pentole o tegami sul fondo del forno, perché così facendo si potrebbe rovinare lo smalto.
- Non appoggiare pesi elevati sulla porta e non aggrapparsi ad essa.
- A causa della temperatura più elevata del ciclo Pizza, si prevede una rumorosità della ventola di raffreddamento leggermente superiore.

---

# CONSIGLI UTILI

---

## COME LEGGERE LA TABELLA DI COTTURA

La tabella indica la funzione, gli accessori e il livello migliore da utilizzare per cuocere svariati tipi di cibo. I tempi di cottura si intendono dall'introduzione degli alimenti nel forno, escluso il preriscaldamento (dove richiesto). Le temperature e i tempi di cottura sono indicativi e dipendono dalla quantità di cibo e dal tipo di accessori. Utilizzare inizialmente i valori più bassi consigliati e, se il risultato della cottura non è quello desiderato, passare a quelli più alti. Si consiglia di utilizzare gli accessori in dotazione e tortiere o teglie possibilmente in metallo scuro. È possibile utilizzare anche tegami e accessori in pyrex o in ceramica, ma occorre considerare che i tempi di cottura si allungheranno leggermente.

---

## COTTURA SIMULTANEA DI PIETANZE DIVERSE

Utilizzando la funzione "Termoventilato", è possibile cuocere contemporaneamente alimenti diversi (ad esempio: pesce e verdure) che richiedono la stessa temperatura, su differenti ripiani. Si potranno estrarre prima gli alimenti che richiedono tempi di cottura più brevi e lasciare continuare la cottura per quelli che necessitano di tempi più lunghi.

---

## CARNE

Utilizzare qualunque tipo di teglia o pirofila adatta alle dimensioni della carne da cuocere. Per gli arrostiti, aggiungere preferibilmente del brodo sul fondo della pirofila inumidendo la carne durante la cottura per insaporirla. Fare attenzione al vapore che si sviluppa durante tale operazione. Quando l'arrosto è pronto, lasciarlo riposare in forno per altri 10-15 minuti oppure avvolgerlo in un foglio di alluminio.

Per la cottura uniforme della carne alla griglia, scegliere tagli dello stesso spessore. I pezzi di carne molto spessi richiedono tempi di cottura più lunghi. Per evitare che si brucino in superficie, allontanarli dal grill disponendoli su ripiani più bassi. Girare la carne a due terzi della cottura. Aprire con cautela la porta in quanto può fuoriuscire vapore caldo.

Si consiglia di posizionare una leccarda con mezzo litro d'acqua potabile direttamente sotto la griglia sulla quale avete posizionato il cibo da grigliare, per raccogliere il liquido di cottura. Rabboccare se necessario.

## DESSERT

Cuocere i dessert delicati con la funzione statica su un solo livello.

Utilizzare tortiere in metallo scuro e posizionarle sempre sulla griglia in dotazione. Per la cottura su più livelli selezionare la funzione termoventilato e disporre le tortiere sfalsate sulle griglie, in modo da favorire la circolazione dell'aria.

Per capire se la torta lievitata è cotta, inserire uno stuzzicadenti nella parte centrale del dolce. Se lo stuzzicadenti rimane asciutto, il dolce è pronto.

Se si utilizzano tortiere antiaderenti, non imbrattare i bordi, il dolce potrebbe non crescere omogeneamente sui lati.

Se il dolce si "sgonfia" durante la cottura, la volta successiva utilizzare una temperatura inferiore, magari riducendo la quantità di liquido e mescolando più delicatamente l'impasto.

































I dessert con guarnitura succosa (torte al formaggio o crostate di frutta) richiedono la funzione "Ventilato". Se la base della torta risulta troppo umida, usare un ripiano più basso e cospargere la base del dolce di pan grattato o biscotti sbriciolati prima di aggiungere il ripieno.

---

## LIEVITAZIONE



Si consiglia di coprire l'impasto con un panno umido prima di introdurlo nel forno. Con questa funzione, i tempi di lievitazione si riducono di circa un terzo rispetto ai tempi di lievitazione a temperatura ambiente (20-25°C). Il tempo di lievitazione per un impasto da pizza da 1 kg è di circa un'ora.

# TABELLA DI COTTURA PER FRITTURA AD ARIA

	RICETTA	FUNZIONE	QUANTITÀ CONSIGLIATA	PRERISC.	TEMPERATURA (°C)	DURATA (MIN.)	RIPIANI E ACCESSORI
ALIMENTI SURGELATI	Patate fritte surgelate		650 - 850 g	Sì	200	25 - 30	 
	Nugget di pollo surgelati		500 g	Sì	200	15 - 20	 
	Bastoncini di pesce		500 g	Sì	220	15 - 20	 
	Anelli di cipolle		500 g	Sì	200	15 - 20	 
VERDURE	Zucchini freschi impanati		400 g	Sì	200	15 - 20	 
	Patatine fritte fatte in casa		300 - 800 g	Sì	200	20 - 40	 
	Verdure miste		300 - 800 g	Sì	200	20 - 30	 
CARNE E PESCE	Petti di pollo		1 - 4 cm	Sì	200	20 - 40	 
	Alette di pollo		200 - 1500 g	Sì	220	30 - 50	 
	Cotolette impanate		1 - 4 cm	Sì	220	20 - 50	 
	Filetti di pesce		1 - 4 cm	Sì	220	15 - 25	 

Per cucinare alimenti freschi o fatti in casa, distribuire uno strato sottile di olio sulla superficie dell'alimento. Per garantire risultati di cottura uniformi, mescolare gli alimenti a metà del tempo di cottura consigliato.

FUNZIONI	 Frittura ad aria		
----------	---	--	--

ACCESSORI	 Teglia frittura ad aria	 Pirofila o tortiera su griglia	 Leccarda/piastra dolci o teglia su griglia
-----------	--	---	---

# TABELLA DI COTTURA

RICETTA	FUNZIONE	PRERISC.	TEMPERATURA (°C)	TEMPO COTTURA (Min.)	LIVELLO E ACCESSORI
Torte lievitate / Pan di Spagna		-	170	30 - 50	2 
		Si	160	30 - 50	2 
		Si	160	30 - 50	4 1 
Torte ripiene (cheesecake, strudel, torta di mele)		-	160 - 200	30 - 85	3 
		Si	160 - 200	35 - 90	4 1 
Biscotti / Crostatine		-	160 - 170	20 - 40	3 
		Si	150 - 160	20 - 40	4 
		Si	150 - 160	20 - 40	4 1 
		Si	135	50 - 90	5 4 3 1 
Crostate		Si	170	50 - 80	5 4 3 1 
Bigné		-	180 - 200	30 - 40	3 
		Si	180 - 190	35 - 45	4 1 
		Si	180 - 190	35 - 45*	5 3 1 
Meringhe		Si	90	110 - 150	3 
		Si	90	130 - 150	4 1 
		Si	90	140 - 160*	5 3 1 
Pizza (sottile, alta, focaccia)		Si	310	7-12	2 
		Si	220 - 240	20 - 40	4 1 
		Si	220 - 240	25 - 50*	5 3 1 
		Si	210	40 - 60	5 4 3 1 
Pagnotta 0,5 kg		-	180 - 220	50 - 70	2 
Panini		-	180 - 220	30 - 50	3 
Pane		Si	180 - 220	30 - 60	4 1 
Pizza surgelata		Si	250	10 - 15	2 
		Si	250	10 - 20	4 1 
Torte salate (torta di verdure, quiche)		Si	180 - 190	45 - 60	2 
		Si	180 - 190	45 - 60	4 1 
		Si	180 - 190	45 - 70*	5 3 1 

FUNZIONI							
	Statico	Grill	Turbo Grill	Termoventilato	Ventilato	ECO	Frittura ad aria

FUNZIONI AUTOMATICHE					
	Primi piatti	Carne	Pane	Funzione pizza	Dolci

ACCESSORI					
	Griglia	Pirofila o tortiera su griglia	Leccarda/piastra dolci o teglia su griglia	Leccarda / Teglia	Leccarda con 500 ml di acqua

RICETTA	FUNZIONE	PRERISC.	TEMPERATURA (°C)	TEMPO COTTURA (Min.)	LIVELLO E ACCESSORI
Vols-au-vent / Salatini di pasta sfoglia		Si	190 - 200	20 - 30	3
		Si	180 - 190	20 - 40	4 1
		Si	180 - 190	20 - 40*	5 3 1
Lasagne/Timballi		-	190 - 200	40 - 80	3
Pasta al forno/Cannelloni		-	190 - 200	25 - 60	3
Agnello / Vitello / Manzo / Maiale 1 kg		-	190 - 200	60 - 90	3
Pollo / Coniglio / Anatra 1 kg		-	200 - 230	50 - 80 **	3
Tacchino / Oca 3 kg		-	190 - 200	90 - 150	2
Pesce al forno / al cartoccio (filetti, intero)		Si	180 - 200	40 - 60	3
Verdure ripiene (pomodori, zucchine, melanzane)		Si	180 - 200	50 - 60	2
Pane tostato		-	3 (Alta)	3 - 6	5
Filetti di pesce / Bistecche		-	2 (media)	20 - 30***	4 3
Salsicce / Spiedini / Costine / Hamburger		Si	200 - 220	15 - 30***	5 4
Pollo arrosto (1-1,3 kg)		Si	200 - 220	55 - 70**	2 1
Roast beef al sangue (1 kg)		-	2 (media)	35 - 50**	3
Coscia d'agnello / Stinco		-	2 (media)	60 - 90**	3
Patate arrosto		Si	200 - 220	35 - 55**	3
Verdure gratinate		Si	200 - 220	10 - 25	3
Pasto completo: Crostata di frutta (livello 5) / Lasagne (livello 3) / Carne (livello 1)		Si	190	40 - 120*	5 3 1
Pasto completo: Crostata di frutta (livello 5) / Verdure arrostate (livello 4) / Lasagne (livello 2) / Tagli di carne (livello 1)		Si	190	40 - 120*	5 4 2 1
Lasagne e carne		Si	200	50 - 120*	4 1
Carne e patate		Si	200	45 - 120*	4 1
Pesce e verdure		Si	180	30 - 50	4 1
Arrosti ripieni	ECO	-	200	80 - 120*	3
Carne in pezzi (coniglio, pollo, agnello)	ECO	-	200	50 - 120*	3

\* Il tempo di cottura è indicativo: i piatti possono essere estratti dal forno in momenti diversi, a seconda delle preferenze personali.





















\*\* Girare gli alimenti a due terzi della cottura (se necessario).

\*\*\* Girare gli alimenti a metà cottura.



FUNZIONI						ECO	
	Statico	Grill	Turbo Grill	Termoventilato	Ventilato	ECO	Frittura ad aria
FUNZIONI AUTOMATICHE							
	Primi piatti	Carne	Pane	Funzione pizza	Dolci		
ACCESSORI							
	Griglia	Pirofila o tortiera su griglia	Leccarda/piastra dolci o teglia su griglia	Leccarda / Teglia	Leccarda con 500 ml di acqua		



# VAPORE + TABELLA DI COTTURA

ALIMENTO	RICETTA	QUANTITÀ	TEMPO (MIN.)	ACCESSORI	ACQUA
PANE	Pane piccolo	80-100 g	30 - 45		100 ml
	Pane in cassetta	300-500 g	40 - 60		
	Pane	500 g-2 kg	50 - 100		
	Baguette	200-300 g	30 - 45		
PASTICCERIA	Biscotti	una teglia	25 - 35		
	Muffin	30-60 g	25 - 45		
	Pan di spagna	500-700 g	30 - 50		
	Crostata	una teglia	35 - 55		
CARNE	Arrosto	1 kg	60 - 110		200 ml
	Costine	500 g-1,5 kg	50 - 75		
	Pollo	1-1,5 kg	55 - 80		
	Pollo/tacchino	3 kg	100 - 140		
PESCE	Bistecca di manzo	0,5-2 cm	15 - 25		
	Bistecca di manzo	2-4 cm	20 - 35		
	Pesce intero	300 - 600 g	20 - 30		
	Pesce intero	600 -1200 g	25 - 45		
VERDURE	Patate arrosto	0,5-1,5 kg	45 - 60		
	Peperoni ripieni	1-2 kg	35 - 55		
	Broccoli arrostiti	0,3-1 kg	30 - 50		
	Zucchine arrostiti	0,5-1,5 kg	30 - 50		

Attivare la funzione VAPORE+ a forno freddo. L'apertura della porta e il rabbocco dell'acqua durante la cottura possono avere effetti negativi sul risultato finale della cottura.

ACCESSORI			
	Teglia frittura ad aria	Pirofila o tortiera su griglia	Leccarda/piastra dolci o teglia su griglia

# MANUTENZIONE E PULIZIA

**Assicurarsi che il forno si sia raffreddato prima di effettuare qualsiasi intervento di manutenzione o pulizia.**

**Non utilizzare apparecchi a vapore.**

**Non usare pagliette metalliche, panni abrasivi e detergenti abrasivi o corrosivi che possano danneggiare le superfici.**

**Indossare guanti protettivi.**

**Il forno deve essere scollegato dalla rete elettrica prima di effettuare qualsiasi tipo di manutenzione.**

## SUPERFICI ESTERNE

- Pulire le superfici con un panno in microfibra umido. Se molto sporche, aggiungere qualche goccia di detergente con pH neutro. Asciugare con un panno.
- Non utilizzare detergenti corrosivi o abrasivi. Se inavvertitamente uno di questi prodotti dovesse venire a contatto con le superfici, pulire subito con un panno in microfibra umido.

## SUPERFICI INTERNE

- Dopo ogni uso, lasciare raffreddare il forno e pulirlo preferibilmente quando è ancora tiepido per rimuovere incrostazioni e macchie dovute a residui di cibo. per asciugare la condensa dovuta alla cottura di alimenti ad alto contenuto di acqua, usare a forno freddo un panno o una spugna.

- Attivare la funzione "Smart Clean" per una pulizia ottimale delle superfici interne. (Solo in alcuni modelli).
- Pulire i vetri della porta con detergenti liquidi specifici.
- La porta del forno può essere rimossa per facilitare la pulizia.

## ACCESSORI

Mettere a bagno gli accessori con detersivo per piatti dopo l'uso, maneggiandoli con guanti da forno, se ancora caldi. I residui di cibo possono essere rimossi con una spazzola per piatti o con una spugna. Non pulire la sonda alimenti e la sonda carne (se presente) in lavastoviglie. La teglia per frittura ad aria (se presente) può essere lavata in lavastoviglie.

## PULIZIA DEI PANNELLI CATALITICI

(SOLO IN ALCUNI MODELLI)

Questo forno è equipaggiato con degli speciali pannelli catalitici che facilitano la pulizia della cavità grazie a un particolare rivestimento autopulente ad alta porosità, in grado di catturare lo sporco. Questi pannelli sono montati sulle griglie laterali: quando queste vengono rimosse, per un corretto posizionamento, assicurarsi che l'aggancio superiore delle griglie sia infilato negli appositi fori dei pannelli.

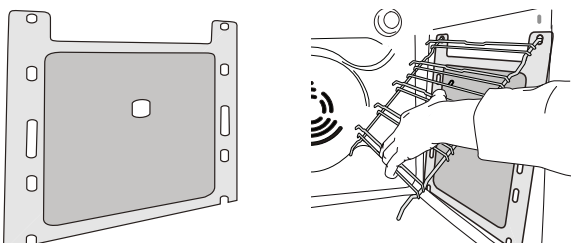

Per utilizzare al meglio le proprietà autopulenti, Si consiglia di riscaldare il forno a 200°C per circa 1 ora utilizzando la funzione "Ventilato". Durante questa procedura il forno deve essere vuoto. Lasciare quindi raffreddare l'apparecchio e infine rimuovere eventuali residui di alimenti con una spugna non abrasiva.

Note: l'uso di detergenti corrosivi o abrasivi, spazzole ruvide, spugne abrasive per pentole o spray per forno possono danneggiare la superficie catalitica, facendole perdere le sue particolari proprietà.

Nel caso fosse necessaria la sostituzione dei pannelli, rivolgersi al Servizio Assistenza Tecnica.

## SOSTITUZIONE DELLA LAMPADINA

Per la sostituzione della luce, contattare il servizio di assistenza.

## RIMOZIONE E MONTAGGIO DELLA PORTA

**1.** Per rimuovere la porta, aprirla completamente e abbassare i fermi fino alla posizione di sblocco.

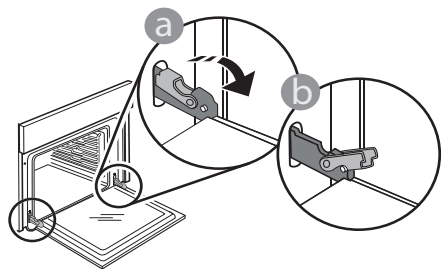

**2.** Chiudere la porta fino a quando è possibile. Prendere saldamente la porta con entrambe le mani, evitando di tenerla per la maniglia. È sufficiente rimuovere la porta continuando a chiuderla e tirandola contemporaneamente verso l'alto, finché non si sgancia dalla propria sede. Togliere la porta e appoggiarla su un piano morbido.

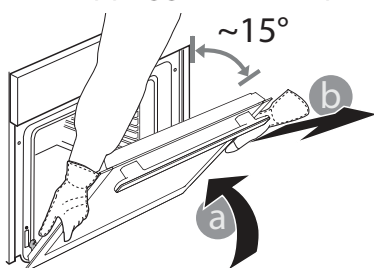

**3.** Per rimontare la porta, avvicinarla al forno allineando i ganci delle cerniere alle proprie sedi e ancorare la parte superiore agli alloggiamenti.

**4.** Abbassare la porta e poi aprirla completamente. Abbassare i fermi nella posizione originale: fare attenzione che siano completamente abbassati.

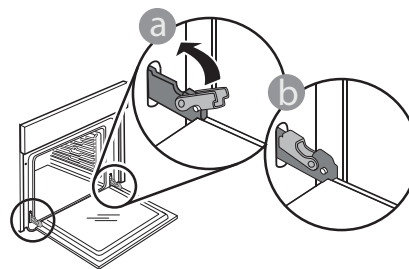

Sarà necessario applicare una leggera pressione per assicurare il corretto posizionamento dei fermi.

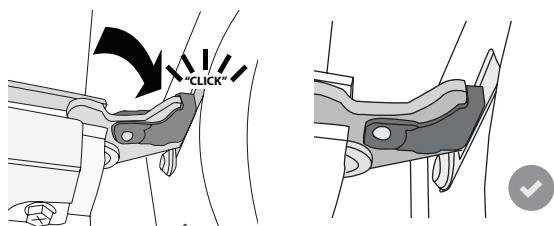

**5.** Provare a chiudere la porta, verificando che sia allineata al pannello di controllo. Nel caso non lo fosse, ripetere i passi sopra descritti: La porta potrebbe danneggiarsi se non funziona correttamente.

## ABBASSARE LA RESISTENZA SUPERIORE

(SOLO IN ALCUNI MODELLI)

**1.** Rimuovere le griglie laterali.

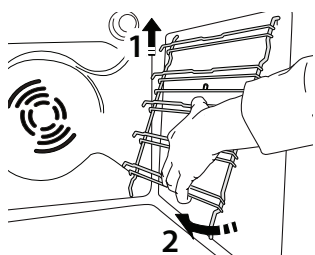

**2.** Estrarre leggermente la resistenza e abbassarla.

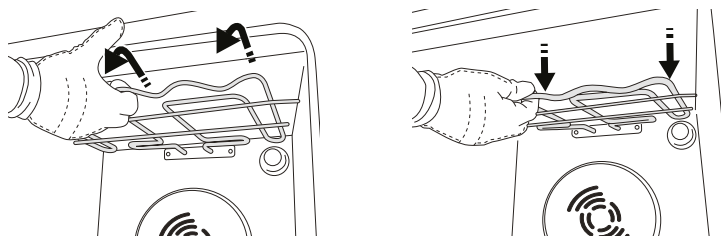

**3.** Per riposizionare la resistenza, sollevarla, tirandola leggermente verso di sé, assicurandosi che poggia sulle apposite sedi laterali.

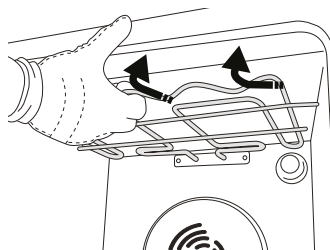

# RISOLUZIONE DEI PROBLEMI

Problema	Possibile causa	Soluzione
Il forno non funziona.	Interruzione di corrente elettrica. Disconnessione dalla rete principale.	Verificare che ci sia tensione in rete e che il forno sia collegato all'alimentazione elettrica. Spegner e riaccendere il forno e verificare se l'inconveniente persiste.
Il display mostra la lettera "F" seguita da un numero.	Problema software.	Contattare il Call Center e indicare il numero che segue la lettera "F".
Il display visualizza un testo poco chiaro e sembra essere guasto.	Un'altra lingua impostata.	Contattare il Call Center.
Il ciclo di cottura con la sonda è terminato senza una causa evidente o l'errore F3E3 è stampato sullo schermo.	La sonda alimenti non è collegata correttamente.	Controllare il collegamento della sonda alimenti.

## Per le linee guida, la documentazione standard e altre informazioni sui prodotti:

- Utilizzare il QR sul proprio prodotto
- Visitare il nostro sito web **docs.bauknecht.eu**
- Oppure, **contattare il Servizio Assistenza Tecnica** (al numero di telefono riportato sul libretto di garanzia). Prima di contattare il Servizio Assistenza Clienti, prepararsi a fornire i codici riportati sulla targhetta matricola del prodotto.

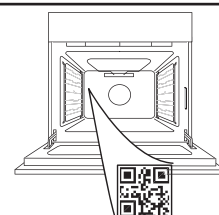

Whirlpool



400020001066

**GRACIAS POR ADQUIRIR UN PRODUCTO  
WHIRLPOOL**

Para recibir una asistencia más completa, registre su producto en [www.whirlpool.eu/register](http://www.whirlpool.eu/register)

ESCANEE EL CÓDIGO QR DE SU  
APARATO PARA OBTENER MÁS  
INFORMACIÓN

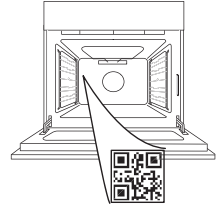

Antes de usar el aparato, lea atentamente las Instrucciones de seguridad.

## DESCRIPCIÓN DEL PRODUCTO

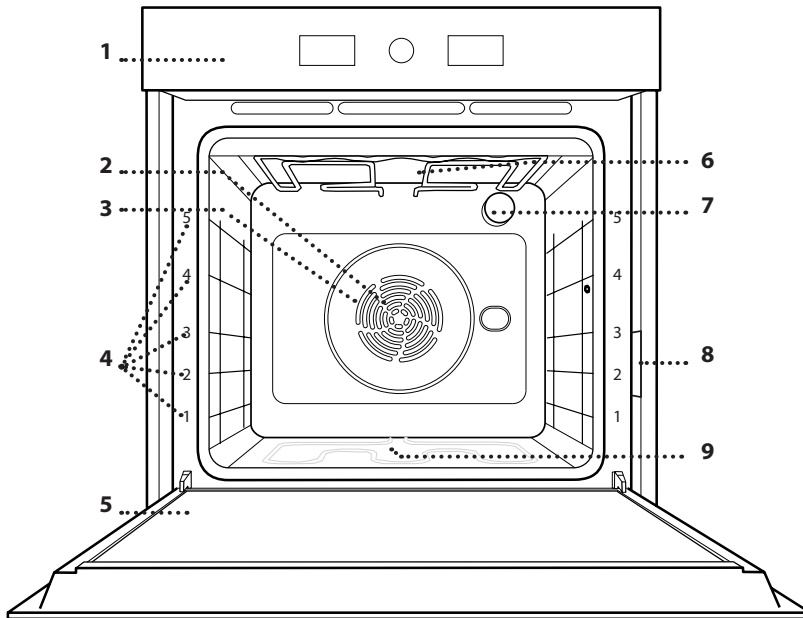

1. Panel de control
2. Ventilador
3. Elemento calefactor circular (no visible)
4. Guías para estantes (el nivel está indicado en la parte frontal del horno)
5. Puerta
6. Resistencia superior / grill
7. Lámpara
8. Placa de características (no debe retirarse)
9. Resistencia inferior (no visible)

## PANEL DE CONTROL

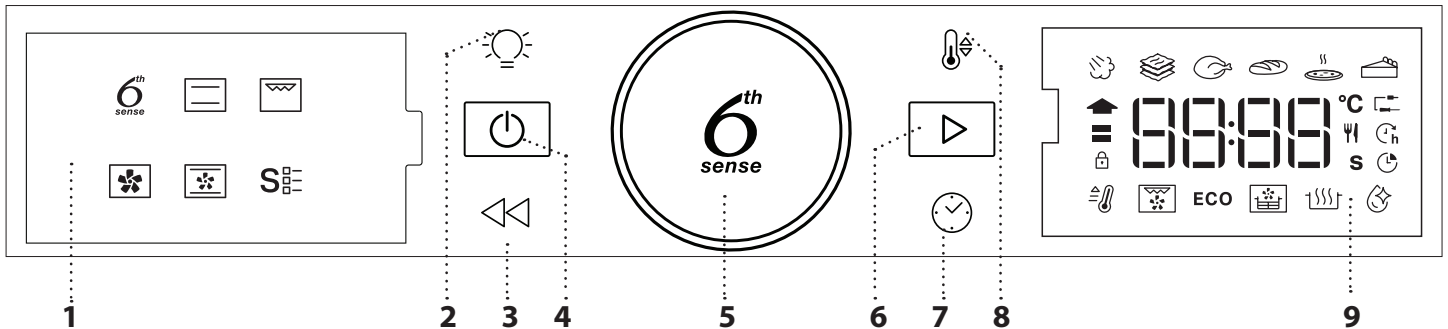

### 1. PANTALLA DE LA IZQUIERDA

#### 2. LUZ

Para encender/apagar la luz.

#### 3. ATRÁS

Sirve para volver a la pantalla anterior. Durante la cocción, permite cambiar los ajustes.

#### 4. ON/OFF

Para encender o apagar el horno y para detener una función activa en cualquier momento.

### 5. POMO GIRATORIO

Gírelo para desplazarse por las funciones y ajustar todos los parámetros de cocción. Pulse para seleccionar, programar, acceder o confirmar las funciones o parámetros, y, eventualmente, para iniciar el programa de cocción.

### 6. INICIO

Para iniciar funciones y confirmar ajustes o un valor programado.

### 7. TIEMPO

Para configurar la hora y ajustar o modificar el tiempo de cocción.

### 8. TEMPERATURA

Para ajustar la temperatura.

### 9. PANTALLA DE LA DERECHA

# ACCESORIOS

## REJILLA

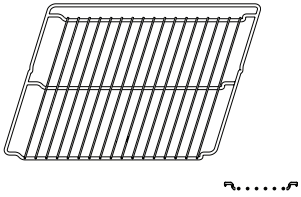

Para cocinar alimentos o como soporte de cazuelas, moldes de tartas y otros recipientes de cocción aptos para horno.

## GRASERA

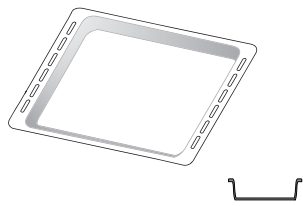

Para utilizar como bandeja de horno para cocinar carne, pescado, verduras, focaccia, etc. o para recoger los jugos de la cocción debajo de la rejilla.

## BANDEJA PASTELERA \*

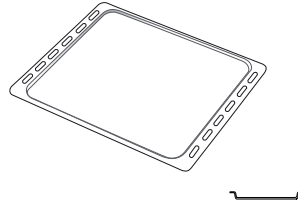

Se utiliza para la cocción de pan y pasteles, pero también para asados, pescado en papillote, etc.

## GUÍAS DESLIZANTES \*

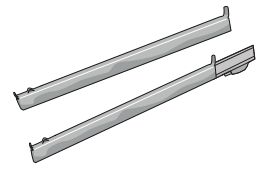

Para facilitar la inserción y extracción de accesorios.

## BANDEJA FREIDORA DE AIRE\*

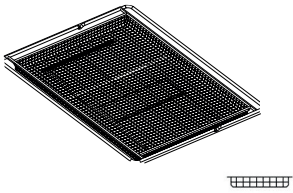

Para utilizar cuando se cocinan alimentos con la función Freidora de aire, con una bandeja de horno colocada a un nivel inferior para recoger posibles migas y goteos. Se puede lavar en el lavavajillas.

El número y el tipo de accesorio puede variar dependiendo del modelo comprado. Otros accesorios pueden adquirirse por separado; para pedidos e información, póngase en contacto con el servicio posventa.

\* Disponible solo en determinados modelos

## INTRODUCCIÓN DE LA PARRILLA Y OTROS ACCESORIOS

Introduzca la rejilla horizontalmente deslizándola a través de las guías y asegúrese de que el lado con el borde en relieve queda mirando hacia arriba.

Otros accesorios, como la grasera y la bandeja pastelera, se introducen horizontalmente igual que la rejilla.

## CÓMO EXTRAER Y VOLVER A COLOCAR LAS GUÍAS PARA ESTANTES

• Para retirar las guías para estantes, levántelas y saque las partes inferiores de sus alojamientos: Ahora puede extraer las guías.

• Para volver a colocar las guías para estantes, primero colóquelas en su alojamiento superior. Manteniéndolas en alto, deslícelas en el compartimento de cocción, y luego bájelas hasta colocarlas en el alojamiento inferior.

## MONTAJE DE LAS GUÍAS DESLIZANTES

(SI PROCEDE)

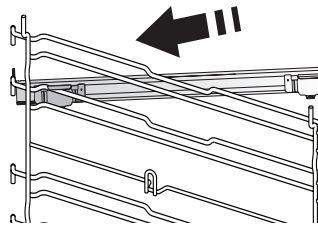

Extraiga las guías para los estantes del horno y quite el plástico de protección de las guías deslizantes.

Fije el cierre superior de la corredera a la guía para los estantes y deslícela hasta el tope. Baje el otro clip a su posición.

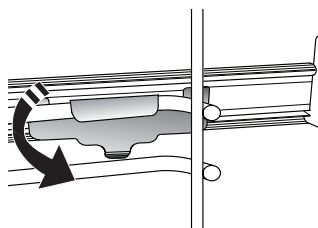

Para fijar la guía, empuje la parte inferior del cierre contra la guía para estantes. Asegúrese de que las guías se pueden mover libremente. Repita estos pasos en la otra guía para estantes del mismo nivel.

Nota: Las guías deslizantes se pueden montar en cualquier nivel.

# FUNCIONES

## 6TH SENSE

Permiten una cocción completamente automática para todo tipo de platos (Lasaña, Carne, Pescado, Verduras, Tartas y pasteles dulces, Tartas saladas, Pan o Pizza). Para sacar el máximo rendimiento a esta función, siga las indicaciones de la tabla de cocción correspondiente.

### VAPOR +

La función Vapor+ permite obtener excelentes rendimientos gracias a la presencia de vapor en el ciclo de cocción. Esta función sugiere la temperatura ideal para cocinar una amplia gama de recetas; los tiempos de cocción de los platos principales se indican en la tabla de cocción relativa. Active siempre la función de vapor cuando el horno esté frío, y después de verter agua potable en el fondo de la cavidad.

### CAZUELA

Esta función sugiere la mejor temperatura y el mejor método de cocción para los platos de pasta.

### CARNE

Esta función sugiere la mejor temperatura y el mejor método de cocción para la carne.

### PAN

Esta función sugiere automáticamente la mejor temperatura y el mejor método de cocción para todos los tipos de pan.

### PIZZA

Esta función le permite cocinar una estupenda pizza casera en menos de 10 minutos, como en un restaurante. El ciclo de cocción específico funciona a una temperatura superior a 300 grados Celsius, proporcionando una pizza suave por dentro, crujiente por los bordes y con un dorado perfectamente uniforme.

Combinando esta función con el accesorio Piedra para Pizza WPro y precalentando durante 30 minutos se puede hornear una pizza en 5-8 min. (Para pedidos e información contacte con el servicio postventa o [www.whirlpool.eu](http://www.whirlpool.eu).)

### TARTAS DULCES

Esta función sugiere la mejor temperatura y el mejor método de cocción para todos los tipos de tarta.

## CONVENCIONAL

Para cocinar cualquier tipo de alimento en un estante.

## GRILL

Para asar al grill filetes, pinchos morunos y salchichas, cocinar verduras gratinadas o tostar pan. Cuando ase carne, le recomendamos colocar la grasera debajo para recoger los jugos de la cocción: Coloque la bandeja en cualquiera de los niveles debajo de la rejilla y añada 500 ml de agua potable.

## AIRE FORZADO

Para hacer diferentes alimentos que requieren la misma temperatura de cocción en varios niveles (máximo tres) al mismo tiempo. Esta función puede utilizarse para cocinar diferentes alimentos sin que se mezclen los olores.

## HORNO CONVECC.

Para cocinar carne y hornear tartas con relleno en un único estante.

## FUNCIONES ESPECIALES

### • PRECALEN. RÁPIDO

Para precalentar el horno rápidamente.

### • TURBO GRILL

Para asar piezas de carne grandes (pierna de cordero, rosbif, pollo). Le recomendamos utilizar la grasera para recoger los jugos de la cocción: Coloque el recipiente en cualquiera de los niveles debajo de la rejilla y añada 500 ml de agua potable.

### • CICLO ECO

Para cocinar piezas de carne asadas con relleno y filetes de carne en un solo estante. Cuando se utiliza el Ciclo Eco, la luz permanece apagada durante la cocción. Para utilizar el ciclo ECO y optimizar el consumo de energía, la puerta del horno no se debe abrir hasta que termine la cocción.

### • ASADO AL AIRE LIBRE/POR CONVECCIÓN

El uso de la bandeja especial para freír (incluida en algunos modelos) permite cocinar patatas fritas, nuggets de pollo y otros alimentos con menos aceite, para que queden agradablemente crujientes. Los elementos calefactores realizan un ciclo para calentar adecuadamente la cavidad, mientras el ventilador hace circular el aire caliente. Coloque los alimentos en la bandeja freidora de aire en una sola capa y siga las instrucciones de la tabla de cocción de la freidora de aire para obtener los mejores resultados.

Alternativamente, esta función puede utilizarse para obtener excelentes resultados de asado en carnes y aves, patatas y verduras, según la recomendación de la tabla de cocción. Estas recetas pueden prepararse utilizando una bandeja de horno estándar.

### • FERMENTAR MASA

Para optimizar la fermentación de masas dulces o saladas. Para garantizar la calidad del leudado, no active la función si el horno está caliente después de un ciclo de cocción.

### • SMART CLEAN

La acción del vapor liberado durante este ciclo especial de limpieza a baja temperatura permite eliminar la suciedad y los residuos de alimentos con facilidad. Vierta 200 ml de agua potable en el fondo del horno y active la función únicamente cuando el horno esté frío.

# PRIMER USO

## 1. CÓMO CONFIGURAR LA HORA

La primera vez que encienda el aparato, tendrá que ajustar la hora.



Los dos dígitos de la hora empezarán a parpadear. Gire el selector para ajustar la hora y pulse  para confirmar.



Los dos dígitos de los minutos empezarán a parpadear. Gire el selector para ajustar los minutos y pulse  para confirmar.

Nota: Para cambiar la hora más adelante, mantenga pulsado  durante como mínimo un segundo con el horno apagado y repita el procedimiento anterior.

Después de un corte de suministro prolongado, es posible que tenga que volver configurar la hora.

## 2. AJUSTES

Si lo desea, puede modificar la corriente nominal por defecto (16 A).



Gire el selector para seleccionar la corriente nominal y pulse  para confirmar.

Nota: El horno está programado para consumir un nivel de potencia eléctrica compatible con el de una red doméstica que tenga una potencia superior a 3 kW (16 A): Si su hogar tiene menos potencia, deberá reducir este valor (13 A).

Nota: Para cambiar la corriente nominal en otro momento, mantenga pulsado  durante al menos cinco segundos mientras el horno está apagado y repita los pasos anteriores.

## 3. CALENTAR EL HORNO



Un horno nuevo puede liberar olores que se han quedado impregnados durante la fabricación: Es completamente normal.

Antes de empezar a cocinar, le recomendamos calentar el horno en vacío para eliminar cualquier olor. Quite todos los cartones de protección o el film transparente del horno y saque todos los accesorios de su interior. Caliente el horno a 200 °C aproximadamente durante una hora, preferiblemente utilizando la función con circulación del aire (p. ej. «Aire forzado» u «Horno de Convección»). Siga las instrucciones para configurar la función correctamente.

Nota: Es aconsejable ventilar la habitación después de usar el aparato por primera vez.

# USO DIARIO

## 1. SELECCIONAR UNA FUNCIÓN

Cuando el horno está apagado, la pantalla solo muestra la hora. Mantenga pulsado  para encender el horno. Gire el selector giratorio para ver las funciones principales disponibles en la pantalla de la izquierda. Seleccione una y pulse .



Para seleccionar una subfunción (en caso de que la haya), seleccione la función principal y después pulse  para confirmar e ir al menú de la función.



Gire el selector rotativo para seleccionar una de las subfunciones disponibles en la parte derecha de la pantalla y después pulse  para confirmar.

## 2. AJUSTAR LA FUNCIÓN

Cuando haya seleccionado la función que desee, puede cambiar la configuración correspondiente. En la pantalla aparecerá la configuración que se puede cambiar por orden.

### TEMPERATURA / NIVEL DEL GRILL



Cuando el icono °C parpadee en la pantalla, gire el mando para modificar el valor y, a continuación, pulse  para confirmar y continuar modificando los ajustes siguientes (si es posible).

También se puede ajustar el nivel del grill (3 = alto, 2 = medio, 1 = bajo) al mismo tiempo.





Nota: Una vez iniciada la función, puede cambiar la temperatura o el nivel del grill pulsando o girando el selector directamente.

### DURACIÓN



Cuando parpadee el icono en la pantalla, utilice el selector de ajuste para ajustar el tiempo de cocción necesario y luego pulse para confirmar.

Si quiere cocinar de forma manual no es necesario configurar el tiempo de cocción: Pulse para confirmar e iniciar la función. En este caso, no puede configurar la hora de finalización de la cocción programando un inicio diferido.

Nota: Pulse para ajustar el tiempo de cocción establecido: Gire el selector para cambiar la hora y pulse para confirmar.

### SELECCIONAR LA HORA DE FINALIZACIÓN DE LA COCCIÓN / INICIO DIFERIDO

En muchas funciones, una vez configurado el tiempo de cocción, podrá retrasar el inicio de la función programando el tiempo final. Cuando pueda cambiar la hora de finalización, la pantalla mostrará la hora a la que terminará la cocción y el icono parpadea.



Si es necesario, gire el selector para configurar la hora a la que quiere que termine la cocción y pulse para confirmar e iniciar la función.

Coloque los alimentos en el horno y cierre la puerta: Esta función se iniciará automáticamente cuando haya transcurrido el periodo de tiempo calculado para que la cocción termine a la hora programada.



Nota: Programar una cocción con inicio diferido deshabilitará la fase de precalentado del horno: el horno alcanzará la temperatura deseada de forma gradual, con lo que los tiempos de cocción serán ligeramente mayores que los de la tabla de cocción.

Durante el tiempo de espera, puede usar el selector para cambiar la hora de finalización programada.

Pulse o para cambiar los ajustes de temperatura y tiempo de cocción. Pulse para confirmar cuando acabe.

### 3. ACTIVAR LA FUNCIÓN

Una vez que haya aplicado la configuración deseada, pulse para activar la función.

Puede mantener pulsado en cualquier momento para poner en pausa la función que esté activada en ese momento.

### 4. PRECALENTAMIENTO

Algunas funciones incluyen una fase de precalentamiento de horno: Una vez iniciada la función, la pantalla indica que se ha activado la fase de precalentado.



Cuando el precalentamiento haya terminado, sonará una señal acústica y la pantalla indicará que el horno ha alcanzado la temperatura establecida.



En ese momento, abra la puerta, introduzca los alimentos en el horno y cierre para iniciar la cocción pulsando .

Nota: Colocar los alimentos en el horno antes de que haya finalizado el precalentado puede tener efectos adversos en el resultado final de la cocción.

Abir la puerta durante la fase de precalentado pausará el proceso.

El tiempo de cocción no incluye la fase de precalentamiento.

Siempre puede cambiar la temperatura que desea que alcance el horno utilizando el selector.

### 5. FINAL DE COCCIÓN

Sonará una señal acústica y la pantalla indicará que la cocción ha terminado.



Para alargar el tiempo de cocción sin cambiar los ajustes, gire el selector para programar un nuevo tiempo de cocción y pulse .

### 6. FUNCIONES 6<sup>TH</sup> SENSE

#### SMART CLEAN

Para activar la función "Smart Clean", con el horno frío, distribuya 200 ml de agua en el fondo de la cavidad del horno y cierre la puerta.

Acceda a las funciones especiales **S** y gire el selector para seleccionar del menú. Luego, pulse para confirmar.

Pulse para iniciar inmediatamente el ciclo de limpieza, o pulse para establecer el tiempo final/ inicio diferido.

---

Al final del ciclo, deje que el horno se enfríe, elimine el agua que pueda quedar en el horno y efectúe la limpieza con una esponja humedecida en agua caliente (si retrasa esta operación más de 15 minutos, podría comprometer el resultado de la limpieza).

Nota: La duración y la temperatura del ciclo de limpieza no se pueden programar.

## 7. BLOQ. DE TECLAS

Para bloquear las teclas, mantenga pulsado  durante al menos cinco segundos.



Vuelva a hacer esto para desbloquear el teclado.

Nota: Esta función también puede activarse durante la cocción. Por motivos de seguridad, puede apagar el horno en cualquier momento pulsando el botón .

## . NOTAS

- No recubra el interior del horno con papel de aluminio.
- No arrastre ollas ni sartenes sobre la base del horno, ya que podrían dañar el revestimiento esmaltado.
- No coloque pesos pesados sobre la puerta ni se agarre a ella.
- Debido a una mayor temperatura del ciclo Pizza, se espera que el ruido del ventilador de refrigeración sea ligeramente superior.

---

## CONSEJOS ÚTILES

---

### CÓMO UTILIZAR LA TABLA DE COCCIÓN

La tabla indica la mejor función, accesorios y nivel para cocinar los diferentes tipos de alimentos. Los tiempos de cocción inician en el momento en que se coloca el alimento en el horno, excluyendo el precalentamiento (cuando sea necesario). Las temperaturas y los tiempos de cocción son orientativos y dependen de la cantidad de alimentos y del tipo de accesorio utilizado. En principio, aplique los valores de ajuste recomendados más bajos y, si la cocción no es suficiente, aumentelos. Utilice los accesorios suministrados y, si es posible, moldes y bandejas pasteleras metálicas de color oscuro. También puede utilizar recipientes y accesorios tipo pírax o de cerámica, aunque deberá tener en cuenta que los tiempos de cocción serán ligeramente mayores.

---

### COCCIÓN DE VARIOS ALIMENTOS A LA VEZ

El uso de la función «Aire forzado» permite cocinar al mismo tiempo distintos alimentos que requieran la misma temperatura (por ejemplo: pescado y verduras), utilizando estantes diferentes. Retire del horno los alimentos que requieran menor tiempo de cocción y deje los que necesiten una cocción más prolongada.

---

### CARNE

Utilice cualquier tipo de bandeja de horno o fuente de Pyrex adecuada al tamaño de la pieza de carne que va a cocinar. En el caso de asados, es conveniente añadir caldo a la base de la fuente y rociar la carne durante la cocción para realzar el sabor. Durante esta operación se generará vapor. Cuando el asado esté listo, déjelo reposar en el horno durante 10 o 15 minutos, o envuélvalo en papel de aluminio.

Cuando desee gratinar carne, elija cortes de carne de igual grosor para obtener un resultado de cocción uniforme. Las piezas de carne muy gruesas requieren tiempos de cocción más prolongados. Para evitar que la carne se queme por fuera, coloque la rejilla en un estante inferior para alejarla del grill. Gire la carne en el segundo tercio del tiempo de cocción. Abra la puerta con cuidado, ya que puede salir vapor caliente. Para recoger los jugos de la cocción, es conveniente colocar una grasera con medio litro de agua directamente debajo de la rejilla en la que se coloque la carne. Reponga el líquido cuando sea necesario.

### POSTRES

Cocine los postres delicados con la función convencional y en un solo nivel.

Utilice bandejas para hornear metálicas de color oscuro y colóquelas siempre sobre la rejilla suministrada. Para cocinar en varios estantes, seleccione la función de aire forzado y disponga los moldes en ellos de modo que la circulación de aire caliente sea óptima.

Para saber si un bizcocho está listo, introduzca un palillo en el centro. Si al retirar el palillo está limpio, el bizcocho está listo.

Si utiliza bandejas para hornear antiadherentes, no unte con mantequilla los bordes, ya que es posible que el bizcocho no suba de manera uniforme por los bordes.

Si el producto se «hincha» durante la cocción, use una temperatura más baja la próxima vez y plantéese reducir la cantidad de líquido añadido o remover la mezcla más suavemente.



Para postres con relleno húmedo (tartas de queso o de fruta) utilice la función «Horno convección». Si la base del bizcocho o tarta está demasiado líquida, coloque el estante en un nivel más bajo y salpique la base con pan rallado o galletas antes de añadir el relleno.

---





### FERMENTAR MASA

Es conveniente cubrir siempre la masa con un paño húmedo antes de introducirla en el horno. Al utilizar esta función, el tiempo de fermentación de la masa se reduce en un tercio con respecto al tiempo de fermentación a temperatura ambiente (20-25° C). El tiempo de leudado de una pizza de 1 kg es de alrededor de una hora.

# TABLA DE COCCIÓN DE FREIDORA DE AIRE

	RECETA	FUNCIÓN	CANTIDAD RECOMENDADA	RÁPIDO	TEMPERATURA (°C)	DURACIÓN (MIN.)	REJILLAS Y ACCESORIOS
ALIMENTOS CONGELADOS	Patatas Fritas Congeladas		650 - 850 g	Sí	200	25-30	4  2 
	Nugget de pollo congelado		500 g	Sí	200	15 - 20	4  2 
	Palitos de pescado		500 g	Sí	220	15 - 20	4  2 
	Aros de cebolla		500 g	Sí	200	15 - 20	4  2 
VERDURAS	Calabacín fresco empanado		400 g	Sí	200	15 - 20	4  2 
	Patatas fritas caseras		300-800 g	Sí	200	20 - 40	4  2 
	Verduras variadas		300-800 g	Sí	200	20 - 30	4  2 
CARNE Y PESCADO	Pechugas de pollo		1-4 cm	Sí	200	20 - 40	4  2 
	Alitas de pollo		200-1500 g	Sí	220	30 - 50	4  2 
	Chuleta empanada		1-4 cm	Sí	220	20 - 50	4  2 
	Filete de pescado		1-4 cm	Sí	220	15 - 25	4  2 

Para cocinar alimentos frescos o caseros, extienda una fina capa de aceite sobre la superficie del alimento.  
Para garantizar resultados de cocción uniformes, mezcle los alimentos a mitad del tiempo de cocción recomendado.

FUNCIONES	 Freidora de aire		
ACCESORIOS	 Bandeja Freír con aire	 Bandeja de horno o molde sobre rejilla	 Grasera/bandeja pastelera o bandeja sobre rejilla

# TABLA DE COCCIÓN

RECETA	FUNCIÓN	RÁPIDO	TEMPERATURA (°C)	TIEMPO COCCIÓN (min.)	NIVEL Y ACCESORIOS
Leavened cakes / Bizcochos esponjosos		-	170	30 - 50	2 
		Sí	160	30 - 50	2 
		Sí	160	30 - 50	4 1 
Tartas rellenas (tarta de queso, strudel, tarta de manzana)		-	160 - 200	30 - 85	3 
		Sí	160 - 200	35 - 90	4 1 
Galletas / Pastelitos		-	160 - 170	20 - 40	3 
		Sí	150 - 160	20 - 40	4 
		Sí	150 - 160	20 - 40	4 1 
		Sí	135	50 - 90	5 4 3 1 
Tartas		Sí	170	50 - 80	5 4 3 1 
Lionesas		-	180 - 200	30 - 40	3 
		Sí	180 - 190	35 - 45	4 1 
		Sí	180 - 190	35 - 45*	5 3 1 
Merengues		Sí	90	110 - 150	3 
		Sí	90	130 - 150	4 1 
		Sí	90	140 - 160*	5 3 1 
Pizza (Fina, gruesa, focaccia)		Sí	310	7-12	2 
		Sí	220 - 240	20 - 40	4 1 
		Sí	220 - 240	25 - 50*	5 3 1 
		Sí	210	40 - 60	5 4 3 1 
Pan de molde 0,5 kg		-	180 - 220	50 - 70	2 
Panecillo		-	180 - 220	30 - 50	3 
Pan		Sí	180 - 220	30 - 60	4 1 
Pizza congelada		Sí	250	10-15	2 
		Sí	250	10 - 20	4 1 
Tartas saladas (tarta de verdura, quiche)		Sí	180 - 190	45 - 60	2 
		Sí	180 - 190	45 - 60	4 1 
		Sí	180 - 190	45 - 70*	5 3 1 

FUNCIÓNES						ECO	
	Convencional	Gratinar	Turbo Grill	Aire Forzado	Hornear por convección	ECO	Freidora de aire

FUNCIÓNES AUTOMÁTICAS					
	Cazuela	Carne	Pan	Función Pizza	Pasteles

ACCESORIOS					
	Rejilla	Bandeja de horno o molde sobre rejilla	Grasera/bandeja pastelera o bandeja sobre rejilla	Grasera / bandeja pastelera	Bandeja con 500 ml de agua

RECETA	FUNCIÓN	RÁPIDO	TEMPERATURA (°C)	TIEMPO COCCIÓN (min.)	NIVEL Y ACCESORIOS
Volovanes / Canapés de hojaldre		Sí	190 - 200	20 - 30	3
		Sí	180 - 190	20 - 40	4 1
		Sí	180 - 190	20 - 40*	5 3 1
Lasañas, Pasteles		-	190 - 200	40 - 80	3
Pasta al horno, Canelones		-	190 - 200	25 - 60	3
Cordero / Ternera / Carne de res / Cerdo 1 kg		-	190 - 200	60 - 90	3
Pollo / conejo / pato 1 kg		-	200-230	50 - 80 **	3
Pavo / oca 3 kg		-	190 - 200	90-150	2
Pescado al horno / en papillote (filetes, entero)		Sí	180 - 200	40 - 60	3
Verduras rellenas (tomates, calabacines, berenjenas)		Sí	180 - 200	50 - 60	2
Tostada		-	3 (Alta)	3 - 6	5
Filetes de pescado/de carne		-	2 (Media)	20 - 30***	4 3
Salchichas / Pinchos morunos / Costillas / Hamburguesas		Sí	200-220	15 - 30***	5 4
Pollo asado 1-1,3 kg		Sí	200-220	55 - 70**	2 1
Rosbif poco hecho (1 kg)		-	2 (Media)	35 - 50**	3
Pierna de cordero / Jarretes		-	2 (Media)	60 - 90**	3
Patatas asadas		Sí	200-220	35 - 55**	3
Verduras gratinadas		Sí	200-220	10 - 25	3
Menú completo: Tarta de frutas (nivel 5), lasaña (nivel 3), carne (nivel 1)		Sí	190	40 - 120*	5 3 1
Menú completo: Tarta de frutas (nivel 5) / verduras asadas (nivel 4) / lasaña (nivel 2) / trozos de carne (nivel 1)		Sí	190	40 - 120*	5 4 2 1
Lasañas y carnes		Sí	200	50 - 120*	4 1
Carnes y patatas		Sí	200	45 - 120*	4 1
Pescado y verduras		Sí	180	30 - 50	4 1
Piezas de carne rellenas asadas	ECO	-	200	80-120*	3
Trozos de carne (conejo, pollo, cordero)	ECO	-	200	50 - 120*	3

\* Tiempo de cocción estimado: Los platos se pueden extraer del horno antes o después según los gustos personales.





















\*\* Darle la vuelta al alimento en el segundo tercio de la cocción (si fuera necesario).

\*\*\* Dar la vuelta al alimento a mitad de la cocción.



FUNCIONES						ECO	
	Convencional	Gratinar	Turbo Grill	Aire Forzado	Hornear por convección	ECO	Freidora de aire
FUNCIONES AUTOMÁTICAS							
	Cazuela	Carne	Pan	Pan	Función Pizza	Pasteles	
ACCESORIOS							
	Rejilla	Bandeja de horno o molde sobre rejilla	Grasera/bandeja pastelera o bandeja sobre rejilla	Grasera / bandeja pastelera	Grasera / bandeja pastelera	Bandeja con 500 ml de agua	



## MESA DE COCINA VAPOR+

ALIMENTO	RECETA	CANTIDAD	TIEMPO (MIN.)	ACCESORIOS	AGUA
PAN	Panes pequeños	80-100 g	30 - 45		100 ml
	Barra de pan de molde	300-500 g	40 - 60		
	Pan	500 g -2 kg	50-100		
	Baguettes	200-300 g	30 - 45		
HOJALDRES	Galletas	una bandeja	25 - 35		
	Muffin	30-60 g	25 - 45		
	Bizcocho	500-700 g	30 - 50		
	Tarta	una bandeja	35 - 55		
CARNE	Asado	1 kg	60 - 110		200 ml
	Costillas	500g-1,5 kg	50 - 75		
	Aves	1-1,5 kg	55 - 80		
	Pollo/Pavo	3 kg	100 - 140		
PESCADO	Filete de carne	0.5-2 cm	15 - 25		
	Filete de carne	2-4 cm	20 - 35		
	Pescado entero	300-600 g	20 - 30		
	Pescado entero	600-1200 g	25 - 45		
VERDURAS	Papas asadas	0.5-1.5 kg	45 - 60		
	Pimientos rellenos	1-2 kg	35 - 55		
	Brócoli asado	0.3-1 kg	30 - 50		
	Calabacines asados	0.5-1.5 kg	30 - 50		

Inicie la función VAPOR+ sólo cuando el horno esté frío. Abrir la puerta y rellenar con agua durante la cocción puede tener un efecto adverso en el resultado final de la cocción.

ACCESORIOS			
	Bandeja Freír con aire	Bandeja de horno o molde sobre rejilla	Grasera/bandeja pastelera o bandeja sobre rejilla

# MANTENIMIENTO Y LIMPIEZA

**Asegúrese de que el horno se haya enfriado antes de llevar a cabo las tareas de mantenimiento o limpieza.**

**No utilice productos de lavado con vapor.**

**No utilice estropajos de acero, estropajos abrasivos ni productos de limpieza abrasivos/corrosivos, ya que podrían dañar las superficies del aparato.**

**Utilice guantes protectores.**

**El horno debe desconectarse de la red eléctrica antes de llevar a cabo cualquier trabajo de mantenimiento.**

## SUPERFICIES EXTERIORES

- Limpie las superficies con un paño húmedo de microfibra. Si están muy sucias, añada unas gotas de detergente neutro al agua. Seque con un paño seco.
- No utilice detergentes corrosivos ni abrasivos. Si uno de esos productos entra accidentalmente en contacto con la superficie del aparato, límpielo de inmediato con un paño húmedo de microfibra.

## SUPERFICIES INTERIORES

- Después de cada uso deje que el horno se enfríe y, a continuación, límpielo, preferiblemente cuando aún esté tibio, para quitar los restos o las manchas causadas por los residuos de los alimentos. Para secar la condensación que se haya podido formar debido a la cocción de alimentos con un alto contenido en agua, deje que el horno se enfríe por completo y límpielo con un paño o esponja.

- Active la función «Smart Clean» para unos resultados de limpieza óptimos de las superficies internas. (Solo en algunos modelos).

- Limpie el cristal de la puerta con un detergente líquido adecuado.

- Para limpiar el horno con facilidad, quite la puerta.

## ACCESORIOS

Después del uso sumerja los accesorios en una solución líquida con detergente, utilice guantes si aún están calientes. Los residuos de alimentos pueden quitarse con un cepillo o esponja.

No limpie la sonda para alimentos ni la sonda para carne (si la hay) en el lavavajillas. La bandeja Freír con aire (si la hay) se puede limpiar en el lavavajillas.

## LIMPIEZA DE LOS PANELES CATALÍTICOS

(SOLO EN ALGUNOS MODELOS)

El horno está equipado con paneles catalíticos especiales que facilitan la limpieza de los compartimentos gracias a su capa especial de autolimpieza, que es muy porosa y absorbe la grasa y la suciedad. Estos paneles están fijados a las guías para estantes: Al volver a colocar y fijar las guías para estantes, asegúrese de que los ganchos superiores quedan introducidos dentro de los agujeros adecuados de los paneles.

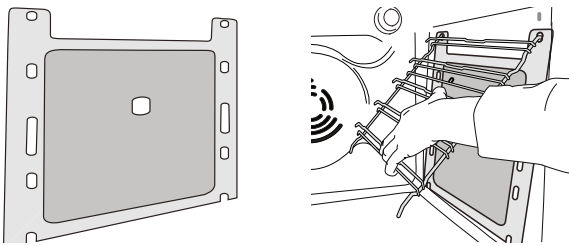

Para sacar el máximo partido a las propiedades de autolimpieza de los paneles catalíticos, recomendamos que caliente el horno a 200 °C durante aproximadamente una hora utilizando la función «Horno de convección». Durante este tiempo, el horno debe permanecer vacío. Deje que el horno se enfríe antes de eliminar los residuos de alimentos con una esponja no abrasiva.

Nota: El uso de detergentes corrosivos o abrasivos, cepillos duros, estropajos para ollas y esprays para horno puede dañar la superficie catalítica y poner en peligro sus propiedades de autolimpieza.

Póngase en contacto con el Servicio Postventa si necesita paneles de recambio.

## SUSTITUCIÓN DE LA LÁMPARA

Para sustituir la lámpara, póngase en contacto con el servicio posventa.



## CÓMO EXTRAER Y VOLVER A COLOCAR LA PUERTA

**1.** Para quitar la puerta, ábrala por completo y baje los pestillos hasta que estén en posición desbloqueada.

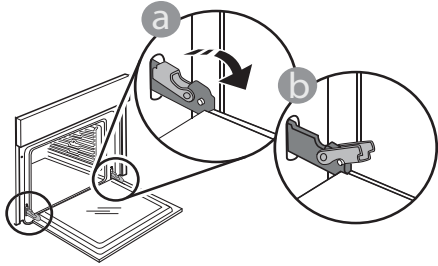

**2.** Cierre la puerta tanto como pueda. Sujete bien la puerta con las dos manos – no la sujete por el asa.

Simplemente extraiga la puerta continuando cerrándola y a la vez levantándola hasta que se salga de su alojamiento. Ponga la puerta en un lado, apoyada sobre una superficie blanda.

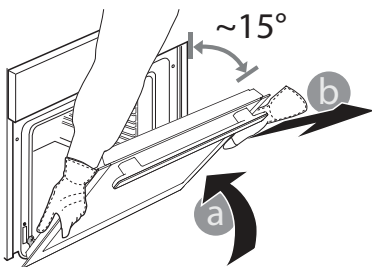

**3.** Vuelva a instalar la puerta llevándola hacia el horno, alineando los ganchos de las ranuras con sus alojamientos y fijando la parte superior en su alojamiento.

**4.** Baje la puerta y ábrala por completo. Baje los pestillos hasta su posición original: Asegúrese de haberlos bajado por completo.

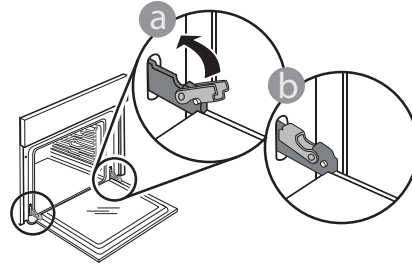

Presione suavemente para comprobar que los pestillos están en la posición correcta.

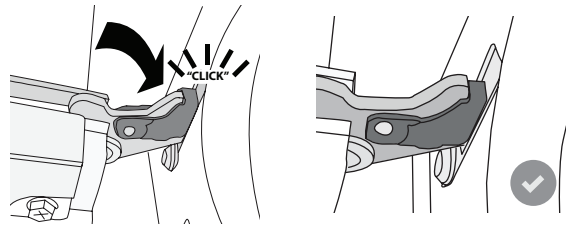

**5.** Intente cerrar la puerta y compruebe que esté alineada con el panel de control. Si no lo está, repita los pasos de arriba: La puerta podría dañarse si no funciona correctamente.

## BAJE LA RESISTENCIA SUPERIOR

(SOLO EN ALGUNOS MODELOS)

**1.** Extraiga las guías laterales para estantes.

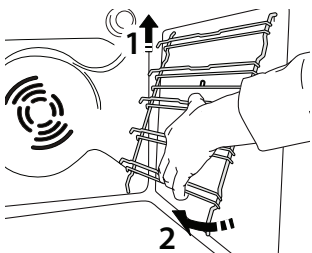

**2.** Extraiga ligeramente la resistencia y bájela.

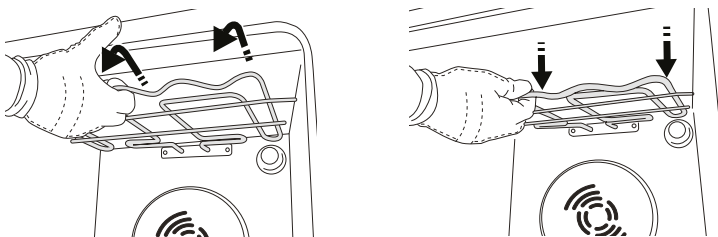

**3.** Para volver a situar la resistencia en su posición, elevarla, tirar de ella ligeramente hacia fuera y comprobar que queda apoyada en las sujeciones laterales.

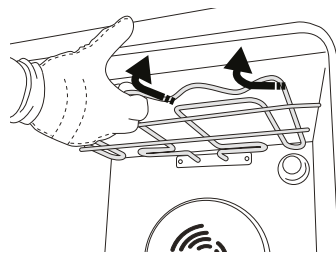

# RESOLUCIÓN DE PROBLEMAS

Problema	Posible causa	Solución
El horno no funciona.	Corte de suministro. Desconexión de la red eléctrica.	Compruebe que haya corriente eléctrica en la red y que el horno esté enchufado a la toma de electricidad. Apague el horno y vuelva a encenderlo para comprobar si se ha solucionado el problema.
En la pantalla aparecerá la letra «F» seguida de un número.	Problema de software.	Póngase en contacto con el Centro de atención telefónica e indique el número que sigue a la letra «F».
La pantalla muestra un texto poco claro y parece estar rota.	Otro idioma configurado.	Póngase en contacto con el Centro de Atención Telefónica.
Ciclo de cocción con sonda finalizado sin causa evidente o error F3E3 aparece impreso en pantalla.	La sonda alimentaria no está bien conectada.	Compruebe la conexión de la sonda alimentaria.

Puede consultar los reglamentos, la documentación estándar e información adicional sobre productos mediante alguna de las siguientes formas:

- Utilizando el QR que aparece en el producto
- Visitando nuestra página web [docs.bauknecht.eu](http://docs.bauknecht.eu)
- También puede **ponerse en contacto con nuestro Servicio Postventa** (Consulte el número de teléfono en el folleto de la garantía). Cuando se ponga en contacto con nuestro Servicio Postventa, deberá indicar los códigos que figuran en la placa de características de su producto.

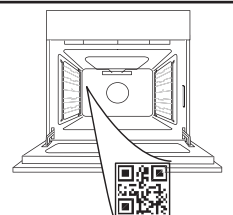

Whirlpool



400020001066