

# AFB 825/A

12NC: 850482515000

GTIN (EAN) code: 8003437130595

**Whirlpool**

SENSING THE DIFFERENCE

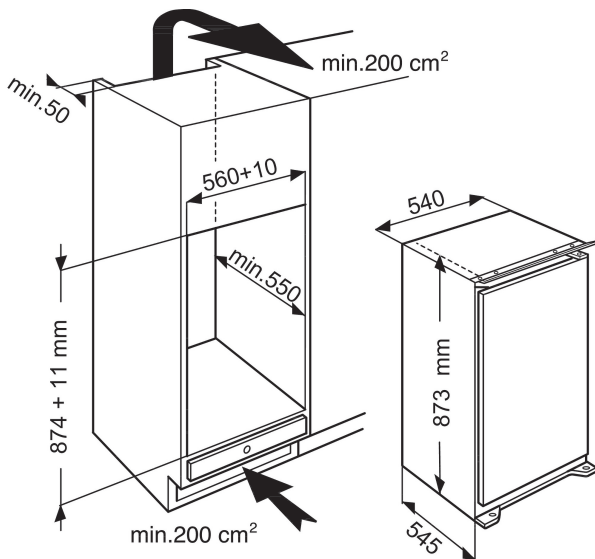

## MAIN FEATURES

Product group	Freezer
Commercial code	AFB 825/A
GTIN (EAN) code	8003437130595
Construction type	Built-in
Installation type	Full-integrated
Type of control	Mechanical
Main colour of product	White
Electrical connection rating (W)	110
Current (A)	13
Voltage (V)	220-240
Frequency (Hz)	50
Length of Electrical Supply Cord (cm)	245
Plug type	UK
Total unit net capacity (l)	91
Height of the product	865
Width of the product	540
Depth of the product	510
Maximum adjustability feet	-
Net weight (kg)	32
Gross weight (kg)	34
Door hinge	-

## TECHNICAL FEATURES

Defrost process	Manual
Fast freezing function	Yes
Refrigerator section with thaw water drainage system	Yes
Number of drawers/baskets	5
Lockable door	-
Thermometer freezer section	None
Interior light	-

## PERFORMANCES

Energy efficiency class - NEW (2010/30/EU)	A
Freezing capacity (kg/24h) - NEW (2010/30/EU)	14
Temperature rise time (h)	16
Climate class	SN
Frost free system	No
Freezer Net capacity (l) - NEW (2010/30/EU)	91