

WIE 2B19 N UK

12NC: 859991607830

GTIN (EAN) code: 8003437611513

Whirlpool

SENSING THE DIFFERENCE

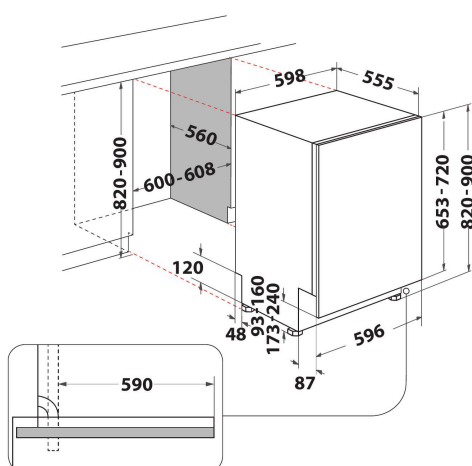

- Installation Type: Built-in
- Energy class A+
- 13 place settings
- Noise level: 49 dB(A)
- 12 L per cycle (3360 L per year)
- Metallic filter
- Adjustable upper rack
- Half load
- Cutlery basket
- Intensive 65°C
- Hot water connection
- Eco 50°C
- 13 place settings and 5 programs
- Electronic control
- Annual energy consumption: 296 kWh/annum
- Water protection system: Overflow
- Energy class A+ and Drying performance A

Whirlpool integrated dishwasher: white color, full size - WIE 2B19 N UK

This Whirlpool integrated Dishwasher features: white color. A+ energy efficiency class. Adjustable feet, for perfect stability on uneven floors and surfaces. Superb cleaning performance, for ideal washing results. Outstanding drying performance, providing excellent results.



Adjustable feet

Tailored for you. This Whirlpool Dishwasher includes adjustable feet, so you can effortlessly set the height of your appliance to fit your needs.



Hot Water connection

Hot water connection. This Whirlpool Dishwasher allows direct connection to a hot water pipe (maximum 60°).



External water protection

This Whirlpool Dishwasher includes an external water protection feature, integrated in the supply pipe, that protects from water flooding in case of an unexpected malfunction.



13 Place Settings

All the space you need. This Whirlpool Dishwasher provides 13 versatile place settings, so you can enjoy all the space you need, always.



Energy class F

Energy savings are ensured at energy class F.



Overflow

Passive water protection system which detects leakages in the tub and prevents flooding in the house. In case of rupture of the tub, the water leaks into the lower compartment of the machine where the floating device triggers the fault alarm. Drain pump is activated and the tub is emptied.



Intensive Programme

Washing program at 65°C long program ideal for the dirtiest dishes



Rapid Cycle

Enjoy rapid results. The Rapid cycle provides all the care and washing power you deserve, in less time.



FlexiSpace

Design your space. FlexiSpace's modular baskets allow you to arrange items freely and easily inside the dishwasher cavity.



Energy class A+

Greater energy efficiency. With its A+ energy rating, this Whirlpool appliance will allow you to enjoy both ideal performance and excellent energy consumption.

WIE 2B19 N UK

12NC: 859991607830

GTIN (EAN) code: 8003437611513

Whirlpool

SENSING THE DIFFERENCE

MAIN FEATURES

Construction type	Built-in
Installation type	Full-integrated
Type of control	Electronic
Type of control settings	-
Removable work top	No
Door decor panel	N/A
Main colour of product	White
Electrical connection rating (W)	1900
Current (A)	13
Voltage (V)	230-240
Frequency (Hz)	50
Length of Electrical Supply Cord (cm)	130
Plug type	UK
Length inlet hose (cm)	155
Length outlet hose (cm)	150
Adjustable plinth	No
Height of removable worktop (mm)	0
Adjustable feet	Yes - all from front
Height of the product	820
Width of the product	598
Depth of the product	555
Depth with open door 90 degree (mm)	-
Minimum niche height	820
Maximum niche height	900
Minimum niche width	600
Maximum niche width	600
Niche depth	560
Net weight (kg)	32.1
Gross weight (kg)	33.9

TECHNICAL FEATURES

Automatic programmes	No
Maximum temperature for water intake (°C)	60
Start delay options	No delay
Start delay time max. (h)	0
Progress indicator	-
Digital countdown indicator	No
Salt light indicator	Yes
Rinse aid light indicator	No
Safety device	Yes
Adjustable upper basket	Yes
Largest loadable dish upper basket (cm)	0
Largest loadable dish lower basket (cm)	0
Number of place settings	13

PERFORMANCES

Energy efficiency class - NEW (2010/30/EU)	A+
Energy consumption annual (kWh/annum) - NEW (2010/30/EU)	296
Duration of the left-on mode - NEW (2010/30/EU)	12
Power consumption in left-on mode - NEW (2010/30/EU)	6
Power consumption in off-mode - NEW (2010/30/EU)	0.5
Water consumption annual (l/annum) - NEW (2010/30/EU)	3360
Noise level (dB(A) re 1 pW)	49

ENERG Y IA
eներգիա - ενεργεια IE IA

WHIRLPOOL WIE 2B19 N UK

A+

296 kWh/annum

3360 L/annum

49 dB

2010/1059