

# FFB 8259 SBSV GCC

12NC: 859991658350

GTIN (EAN) code: 8003437051920

Whirlpool

SENSING THE DIFFERENCE

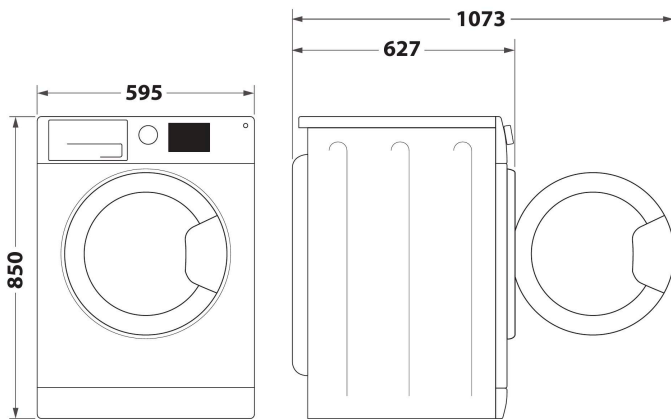

- Energy class A+++
- Washing capacity: 8 kg
- Maximum spin speed: 1200 rpm
- 6TH Sense Technology
- FreshCare+
- Daily 30°
- Daily 40°
- Daily mixed 40°C
- Eco Cotton
- Steam refresh
- Mixed Fabrics Program
- Special Big Items Program
- Sport
- Delicates
- Program Progress Indicators
- Program cancellation
- Clean+

## Whirlpool freestanding front loading washing machine: 8 kg - FFB 8259 SBSV GCC

This Whirlpool freestanding Washing Machine features: silver color. A spacious 8kg capacity. A fast, resource-efficient 1200 revolutions per minute spin speed. Exclusive 6th SENSE technology, that dynamically adapts settings to each specific load, ensuring ideal care for all your fabrics. 30 minute quick wash.



### 6th Sense Technology

Discover perfect care. 6th SENSE intelligent sensors adapt resources according to the size and type of load, offering time, energy and water optimization.



### FreshCare+

100% Freshness even if you forget to unload. No need to adapt your schedule to the laundry chores: your garments will be protected from odours and creasing. FreshCare+ thanks to delicate steaming and tumbling action inhibits the proliferation of the main bad odour sources (inside the washer) for up to 6 hours after the cycle ends, while gentle tumbling prevents fixing of creases.



### Steam Refresh

Steam Refresh regenerates the freshness of your garments avoiding unnecessary washing. Clothes are ready to wear again in just 20 minutes. The washer generates a flow of steam that penetrates into the fibers, removing unpleasant smells, relaxing fibers and smoothing creases.



### Sense Inverter Motor

Silent performance. This Whirlpool Washing machine's innovative SENSE Inverter Motor is designed to ensure a long lasting, silent performance. Enjoy both ideal results and some extra peace and quiet.



### 1200 rpm

Outstanding speed. This Whirlpool Washing Machine features a 1200 rounds per minute spin speed.



### A+++ energy efficiency

Outstanding energy efficiency. With its A+++ energy rating, this Whirlpool Washing machine will allow you to enjoy both ideal results and lower energy consumption.



### 8kg capacity

All the space you need. With its 8kg drum capacity, this Whirlpool Washing Machine provides all the space you need for your laundry.



### Start Delay

Tailored for you. The Start Delay option allows you to set the Washing machine to begin its cycle whenever most convenient for you, saving you both time and energy.

# FFB 8259 SBSV GCC

12NC: 859991658350

GTIN (EAN) code: 8003437051920

Whirlpool

SENSING THE DIFFERENCE

## MAIN FEATURES

Product group	Washing machine
Construction type	Free-standing
Installation type	Free-standing
Removable work top	No
Loading type	Front loader
Main colour of product	Silver
Electrical connection rating (W)	1850
Current (A)	13
Voltage (V)	220-240
Frequency (Hz)	50
Length of Electrical Supply Cord (cm)	120
Plug type	UK
Height of the product	845
Width of the product	595
Depth of the product	630
Net weight (kg)	71

## TECHNICAL FEATURES

Automatic programmes	Yes
Spin speed options	Variable
Skip spin	Yes
Weight measurement	-
Textile type recognition	-
Degree of dirtiness recognition	-
Foam control	Yes
Balance control	Yes
Type of water protection system	No
Cold wash option	No
Progress indicator	-
Digital countdown indicator	Yes
Start delay options	Continuous
Start delay time max. (h)	0
Tub material	Plastic
Drum volume (l)	62
Hot & cold water intake?	No
Gross weight (kg)	72
Height of the packed product	870
Width of the packed product	640
Depth of the packed product	645

ENERGIA - ЕНЕРГИЈА - ENERGIJA - ENERGIJA - ENERGIJA - ENERGIJA - ENERGIJA - ENERGIJA - ENERGIJA - ENERGIJA

**WHIRLPOOL**  
FFB 8259 SBSV GCC

**A+++**

**137**  
kWh/annum

11900  
L/annum

8  
kg

52 dB

79 dB

2010/1061

## PERFORMANCES

Energy efficiency class - NEW (2010/30/EU)	A+++
Energy consumption annual (kWh/annum) - NEW (2010/30/EU)	137
Washing performance class	A
Maximum spin speed (rpm) - NEW (2010/30/EU)	1200
Capacity cotton (kg) - NEW (2010/30/EU)	8
Water consumption annual (l/annum) - NEW (2010/30/EU)	11900
Energy consumption 60 °C full load	0.694
Power consumption in left-on mode - NEW (2010/30/EU)	8
Power consumption in off-mode - NEW (2010/30/EU)	0.5
Moisture content % on dry load after max. spin - NEW (2010/30/EU)	53
Average washing time cotton 60°C (full load) - NEW (2010/30/EU)	230
Noise level washing (dB(A) re 1 pW)	52
Noise level spinning (dB(A) re 1 pW)	79