

AKP 729 IX

12NC: 857772901500

GTIN (EAN) code: 8003437937477

Whirlpool

SENSING THE DIFFERENCE



Whirlpool built in electric oven: inox color - AKP 729 IX

This Whirlpool built in Oven features: advanced electric technology allowing you to cook dishes saving energy. Halogen lamp allowing a more energy-efficient performance.

Multifunction 5

Multiple cooking methods. The Multifunction 5 feature offers flexible cooking options, to ensure perfect results, whatever the recipe.

Absolute aesthetic

The Absolute collection. Admire the beauty of performance. With a futuristic design and unparalleled performance, the Absolute collection is designed for modern, high-tech kitchens. Equipped with innovative 6TH SENSE technology, Absolute ovens can be set in three simple steps for perfect results. Maximum flexibility and ease of use with a distinctive look and original finishes.

Standard cavity

This Whirlpool Oven features a standard-size cavity.

Energy class

Outstanding energy savings. Ovens with an A/ A+ energy rating offer an excellent level of energy efficiency, ensuring lower consumption and saving you money on your energy bills.

Energy class A

Energy efficient. With its A energy rating, this Whirlpool appliance will allow you to enjoy both ideal performance and excellent energy consumption.

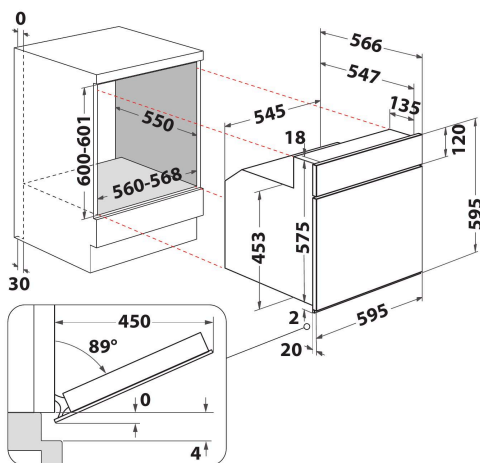

- Energy class A
- Cavity 65 L
- Defrost function
- Grill
- Easy Clean Enamel Interior
- Turbo grill function
- Pastry function
- Conventional Cooking
- Metal handle
- Door Glasses Number: 2
- Protuding handle
- Grill 1400 W
- 1 Grid
- 1 Tray
- Dark Grey Glass and N/A Bottom Front Trim
- Dimensions HxWxD: 595x595x564 mm
- Product Segment: Absolute Inox

AKP 729 IX

12NC: 857772901500

GTIN (EAN) code: 8003437937477

Whirlpool

SENSING THE DIFFERENCE

MAIN FEATURES

Product group	Oven
Commercial code	AKP 729 IX
Main colour of product	Inox
Construction type	Built-in
Type of control	Mechanical
Type of control settings	-
Are any hobs controls integrated?	Yes
Which kind of hobs can be controlled?	-
Automatic programmes	No
Current (A)	13
Voltage (V)	220-240
Frequency (Hz)	50/60
Length of Electrical Supply Cord (cm)	0
Plug type	No
Depth with open door 90 degree (mm)	-
Height of the product	595
Width of the product	595
Depth of the product	564
Minimum niche height	0
Minimum niche width	0
Niche depth	0
Net weight (kg)	34
Usable volume (of cavity)	65
Integrated Cleaning system	No
Grids of the cavity	1
Trays	1

TECHNICAL FEATURES

Timer	No
Time control	No control of the time
Time-setting options	No delay options
Safety device	-
Interior light	Yes
Number of interior lights of the cavity	1
Position of interior lights of the cavity	Rear
Oven guides of the cavity	Grids
Probe of the cavity	No

PERFORMANCES

Energy input	Electric
Type of energy of the cavity	Electricity
Energy efficiency class - NEW (2010/30/EU)	A
Energy consumption per cycle conventional - NEW (2010/30/EU)	0.78
Energy consumption per cycle forced air convection - NEW (2010/30/EU)	0.87



ENERG
енергия · ενεργεια
Y IJA
IE IA

WHIRLPOOL
AKP 729 IX

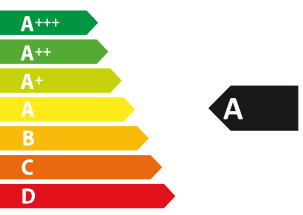

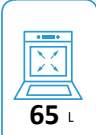

65 L

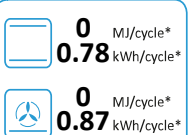

0.78 kWh/cycle*

* цешья · siklus · portion · zklus · πρόγραμμα · ciclo · tsükkel · ohjelma · ciklus
ciklus · ciklus · ciklu · ciklus · cykl · ciclo · program · cycle

65/2014