

# GMA 6414/IXL

12NC: 852442538000

GTIN (EAN) code: 8003437828553

Whirlpool

SENSING THE DIFFERENCE

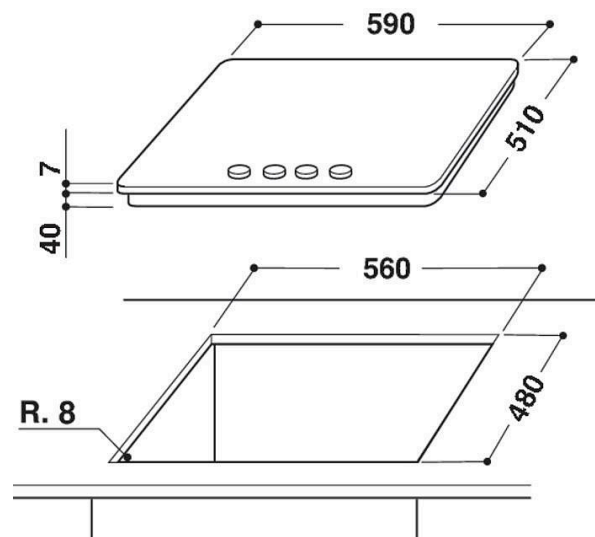

- Cast Iron Pan Supports
- Electromagnetic safety device for each burner
- Wok grid adapter
- Silver painted knobs
- 4 Rounded Cast Iron grids
- Front controls
- 60 cm hob
- Mechanical control
- Ignition type: knob
- Inox iXelium finishing Hob
- 4 Burners
- 4 burners: 1 Ultrarapid 3500 W burner, 1 Semirapid 1650 W burner, 1 Semirapid 1650 W burner, and 1 Auxiliary 1000 W burner.
- Supply cord included
- Dimensions HxWxD: 41x590x510 mm
- Niche dimensions HxWxD: 38x560x480 mm

## Whirlpool gas hob: 4 gas burners - GMA 6414/IXL

This Whirlpool gas Hob features: iXelium stain-resistant surface for effortless cleaning. Cast iron Wok Cooking adapter, specifically tailored for wok use.



### iXelium

Long lasting shine. The revolutionary iXelium treatment protects your hob from scratches and corrosion, ensuring a perfect shine, always. And, it's easy to clean: all you need is water and a soft cloth.

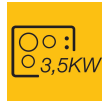

### Power Burner 3500W

3.5kW burner. Enjoy tastier results, faster. Seal your meat to perfection, boil water faster or enjoy a perfect stir-fry dishes with the outstanding Power Burner 3.500W.



### Dishwashable Grids

Keep your hob clean easily and safely thanks to the dishwasher safe grids.



### Wok Cooking

This hob comes with a wok burner and is perfect for stir fries and all fast cooking requirements.



### Easy to clean

Easy cleaning. With our easy-to-clean surfaces, all you need to make your hob shine is a clean, damp cloth.



### Cast Iron Supports

Cast Iron pan supports for that professional look and maximum stability in use.



### Front Controls

Complete control over your cooking. Easily accessible and genuinely intuitive, the controls are conveniently positioned on the front panel of your hob, providing a frictionless cooking experience.

# GMA 6414/IXL

12NC: 852442538000

GTIN (EAN) code: 8003437828553

**Whirlpool**

SENSING THE DIFFERENCE

## MAIN FEATURES

Product group	Hob
Construction type	Built-in
Type of control	Mechanical
Type of control settings	-
Number of gas burners	4
Number of electric cooking zones	0
Number of electric plates	0
Number of radiant plates	0
Number of halogen plates	0
Number of induction plates	0
Number of electric warming zones	0
Location of control panel	Front
Basic surface material	Inoxclearcoat
Main colour of product	Inox
Electrical connection rating (W)	0
Gas connection rating (W)	7800
Gas type	G20
Current (A)	0,2
Voltage (V)	230
Frequency (Hz)	50
Length of Electrical Supply Cord (cm)	85
Plug type	No
Gas connection	Cilindric
Width of the product	590
Height of the product	41
Depth of the product	510
Minimum niche height	38
Minimum niche width	560
Niche depth	480
Net weight (kg)	7.5
Automatic programmes	No

## TECHNICAL FEATURES

Power on indicator	No
Number of indicators	0
Type of regulation	Temperature regulated
Type of lid	Glass
Residual heat indicator	Without
Main on/off switch	No
Safety device	-
Timer	No

## PERFORMANCES

Energy input	Gas
--------------	-----