

# MBNA920B

12NC: 859991659360

GTIN (EAN) code: 8003437396823

Whirlpool

SENSING THE DIFFERENCE

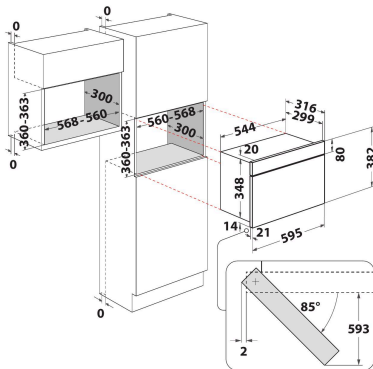

## MAIN FEATURES

Product group	Microwave
Commercial code	MBNA920B
Main colour of product	Черен
Type of micro-wave oven	MW+Grill function
Construction type	Built-in
Type of control	Electronic
Type of control settings	LED
Additional cooking method Grill	Yes
Хрупкаво	No
Steam	No
Additional cooking method Fan cooking	No
Clock	Yes
Automatic programmes	No
Height of the product	382
Width of the product	595
Depth of the product	320
Minimum niche height	360
Minimum niche width	556
Niche depth	300
Net weight (kg)	20
Cavity capacity (l)	22
Turntable	Yes
Turntable diameter (mm)	250
Integrated Cleaning system	No

## TECHNICAL FEATURES

Current (A)	10
Voltage (V)	220-240
Frequency (Hz)	50
Length of Electrical Supply Cord (cm)	135
Plug type	Schuko
Timer	Yes
Grill power (W)	700
Type of grill	Quartz
Cavity material	Painted
Interior light	Yes
Additional cooking method Grill	Yes
Position of interior lights of the cavity	Right side

## ENERGY LABEL

6th Sense / Dynamic Intelligence	No
Number of power levels	4
Maximum micro-wave power (W)	750
Размразяване на хляб	No
Размразяване	Yes
Старт	Yes