

ART 477/5

12NC: 856447715020

GTIN (EAN) code: 8003437036927

Whirlpool

SENSING THE DIFFERENCE

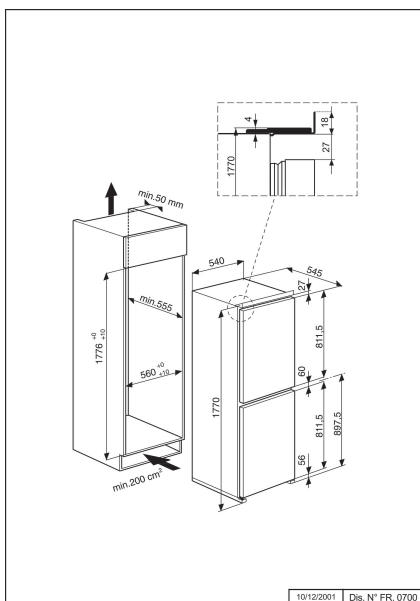

MAIN FEATURES

Product group	Fridge/freezer combination
Installation type	Built-in
Type of control	Mechanical
Construction type	Built-in
Main colour of product	White
Electrical connection rating (W)	140
Current (A)	13
Voltage (V)	220-240
Frequency (Hz)	50
Number of compressors	1
Length of Electrical Supply Cord (cm)	245
Plug type	UK
Total unit net capacity (l)	257
Star Rating	4
Height of the product	1770
Width of the product	540
Depth of the product	545
Maximum adjustability feet	-
Net weight (kg)	58

TECHNICAL FEATURES

Defrost process fridge section	Automatic
Defrost process freezer section	Semi-automatic
Fast cooling possibility	No
Fast freezing function	No
Door opened indicator freezer	No
Temperature adjustable	-
Temperature adjustable freezer	No
Interior ventilator fridge section	No
Number of freezing drawers	4
Automatic motor-driven ice-maker	No
Number of shelves in fridge compartment	4
Material of the shelves	Glass
Thermometer fridge section	None
Thermometer freezer section	None
Number of temperature zones	1

PERFORMANCES

Energy efficiency class - NEW (2010/30/EU)	A
Energy consumption annual (kWh/annum) - NEW (2010/30/EU)	373
Refrigerator Net capacity (l) - NEW (2010/30/EU)	162
Freezer Net capacity (l) - NEW (2010/30/EU)	95
Freezing capacity (kg/24h) - NEW (2010/30/EU)	8
Climate class	SN-ST
Noise level (dB(A) re 1 pW)	39
Frost free system	No