

# GMA 9522/IX

12NC: 859991031820

GTIN (EAN) code: 8003437829123

Whirlpool

SENSING THE DIFFERENCE

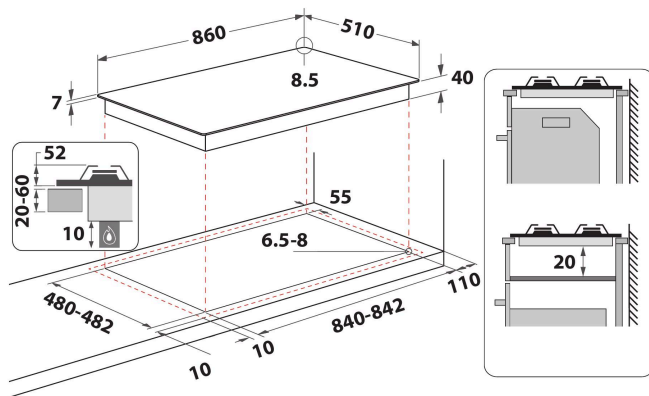

- Cast Iron Pan Supports
- Electromagnetic safety device for each burner
- Silver painted knobs
- 3 Fusion Aphrodite 2 Cast Iron grids
- Front controls
- 90 cm hob
- Mechanical control
- Ignition type: knob
- 5 Burners
- 5 burners: 1 Double crown 4000 W burner, 1 Semirapid 1650 W burner, 1 Rapid 3000 W burner, 1 Auxiliary 1000 W burner, and 1 Semirapid 1650 W burner.
- Supply cord included
- Dimensions HxWxD: 41x860x510 mm
- Niche dimensions HxWxD: 41x840x490 mm
- Voltage: 220-240 V
- Gas Connection Rating: 11300 W

## Whirlpool gas hob: 5 gas burners - GMA 9522/IX

Standard Whirlpool technologies and features for you to enjoy.



### Dishwashable Grids

Keep your hob clean easily and safely thanks to the dishwasher safe grids.



### Power Burner 4000W

4kW burner. Enjoy tastier results, faster. Seal your meat to perfection, boil water faster or enjoy a perfect stir-fry dishes with the outstanding Power Burner 4000W.



### Power Burner 5gas (PB)

Power cooking. This Whirlpool Hob features 5 Power burners to provide extra heat and speed up boiling, frying and steaming, while ensuring maximum energy efficiency.



### Speed to Boil

Enjoy faster boiling. Our innovative technology, by effectively harnessing the energy of the flames, ensures more heat is delivered directly to your pots and pans allowing you to enjoy ideal cooking results, sooner.



### Cast Iron Supports

Cast Iron pan supports for that professional look and maximum stability in use.



### Front Controls

Complete control over your cooking. Easily accessible and genuinely intuitive, the controls are conveniently positioned on the front panel of your hob, providing a frictionless cooking experience.



### Stainless Steel

For the stylish modern look in your kitchen.

# GMA 9522/IX

12NC: 859991031820

GTIN (EAN) code: 8003437829123

**Whirlpool**

SENSING THE DIFFERENCE

## MAIN FEATURES

Product group	Hob
Construction type	Built-in
Type of control	Mechanical
Type of control settings	Knob
Number of gas burners	5
Number of electric cooking zones	0
Number of electric plates	0
Number of radiant plates	0
Number of halogen plates	0
Number of induction plates	0
Number of electric warming zones	0
Location of control panel	Front
Basic surface material	Inox
Main colour of product	Inox
Electrical connection rating (W)	0
Gas connection rating (W)	11300
Gas type	G20
Current (A)	0,2
Voltage (V)	220-240
Frequency (Hz)	50/60
Length of Electrical Supply Cord (cm)	85
Plug type	No
Gas connection	Conic
Width of the product	860
Height of the product	41
Depth of the product	510
Minimum niche height	41
Minimum niche width	840
Niche depth	490
Net weight (kg)	17.8
Automatic programmes	No

## TECHNICAL FEATURES

Power on indicator	No
Number of indicators	0
Type of regulation	Temperature regulated
Type of lid	Without
Residual heat indicator	Without
Main on/off switch	No
Safety device	-
Timer	No

## PERFORMANCES

Energy input	Gas
--------------	-----