

WHVS 91F LT DP K

12NC: 859991678100

GTIN (EAN) code: 8003437056123

Whirlpool

SENSING THE DIFFERENCE

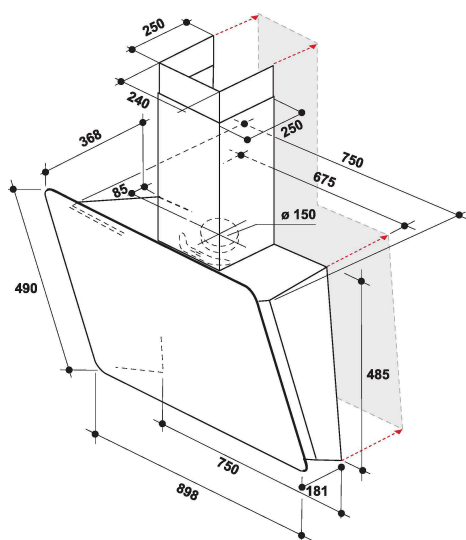

- 6TH Sense technology
- Maximum noise level 65 dBA
- Air Flow (min. - max.): 305, 570, booster 740 m³/h
- Maximum extraction rate: 570 (m³/h)
- Energy class A+
- Extraction / Recirculation Rate
%Z_REQ_MAX_OUT_EXTRACTION% / 445 m³/h
- 4 speed settings + booster
- Anti Condensation System
- 2 LED, 5 W lamps
- 1 x 270 W motor
- Perimetral aspiration
- Electronic Capacitive touch control
- 1 Washable aluminium filter
- Grease Filtering Efficiency Class: D
- Lighting Efficiency Class: A
- Fluid Dynamic Efficiency Class: A

Whirlpool wall mounted cooker hood - WHVS 91F LT DP K

This Whirlpool wall mounted Cooker Hood features: black color. Dishwasher-safe, washable aluminium grease filters. LED lights for ideal lighting. An outstanding cooker extractor fan, ensuring a fresh, grease-free cooking environment. Exclusive 6th SENSE sensor technology that dynamically adjusts energy consumption, depending on what your are cooking.



LED lighting

Increased energy and cost efficiency. The LED lighting system lasts 10 times longer than traditional bulbs and uses 90% less energy.



Anticondensation system

The anti-condensation system works in either manual or automatic mode. If the hood is switched off without deselecting the option, the anti-condensation system activates automatically. The models equipped with this plus have the air outlet placed in both the upper and rear side of the hood. The classic outlet is used in both filtering and extraction mode with an exposed chimney. The innovative rear outlet allows the hood to work in extraction mode by connecting it to an exhaust duct that is already fitted in the wall where the hood will be installed.



Electronic control

Effortless control. This Whirlpool Hood includes an intuitive electronic user interface, designed to provide you with the simplest, most satisfying user experience ever.



4 Speeds

Versatile performance. This Whirlpool Hood offers 4 speed options, giving you complete control over the extraction rate.



Wall-mounted installation

Wall-mounted installation. This wall-mounted Whirlpool Hood is a breeze to install.



Total annual energy consumption

Ideal performance, outstanding savings. Whirlpool Hoods are designed to provide exceptional results, while reducing energy costs.



High efficiency motor

Efficiency first. The motor in this Whirlpool Hood is designed to provide ideal filtration, while ensuring high energy efficiency.



6th sense

Exceptional energy savings. The exclusive 6th SENSE technology allows your hood to dynamically adjust its energy consumption, based on what your are cooking.

WHVS 91F LT DP K

12NC: 859991678100

GTIN (EAN) code: 8003437056123

Whirlpool

SENSING THE DIFFERENCE

MAIN FEATURES

Product group	Hood
Colour body	Black
Material body	Stainless steel / glass
Colour chimney	Black
Material chimney	Metal
Typology	Wall-mounted
Installation type	Wall-mounted
Type of control	Electronic
Type of control settings	-
Decor panel options	N/A
Motor location	Integrated motor in hood body
Operating Mode	Convertible
Electrical connection rating (W)	275
Current (A)	1,2
Voltage (V)	220-240
Frequency (Hz)	50/60
Length of Electrical Supply Cord (cm)	150
Plug type	Schuko
Chimney height (mm)	-
Height of product, without chimney (mm)	504
Height of the product	1475
Width of the product	898
Depth of the product	368
Minimum niche height	0
Minimum niche width	0
Niche depth	0
Net weight (kg)	20.2

TECHNICAL FEATURES

Type of manual control devices	Capacitive touch control
Type of automatic control devices	-
Number of motors	1
Total power of the motors (W)	270
Number of speed settings: boost option availability	4
Boost presence	Yes
Maximum output air extraction (m ³ /h)	570
Boost position air extraction (m ³ /h)	740
Maximum output recirculating air (m ³ /h)	445
Boost position output recirculating (m ³ /h)	465
Light Control Type	On/Off
Number of lights	2
Type of lamps used	LED
Total power of the lamps (W)	5
Diameter of air outlet (mm)	150
No-return airflow flap	Yes
Grease filter material	Washable aluminium
Odour filter	Yes

PERFORMANCES

Sound power at min. speed (2010/30/EU)	52
Sound power at max. speed (2010/30/EU)	65
Noise level with boost position (dB(A) re 1 pW)	57

ENERG Y IJA
енергия · енергия IE IA

WHIRLPOOL
WHVS 91F LT DP K

A+++
A++
A+ **A+**
A
B
C
D

42
kWh/annum

ABCDEF G ABCDEF G ABCDEF G **65** dB

65/2014