

# WHBS 63 F L E X

12NC: 859991549980

GTIN (EAN) code: 8003437233128

**Whirlpool**

SENSING THE DIFFERENCE

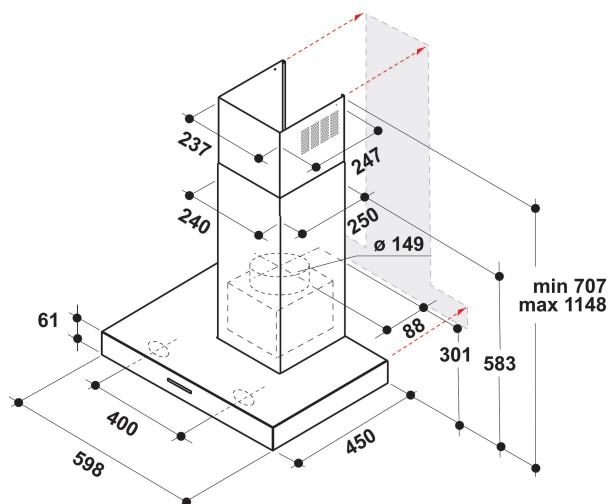

## MAIN FEATURES

Product group	абсорбатори
Colour body	Инокс
Material body	Stainless steel
Colour chimney	Инокс
Material chimney	Stainless steel
Typology	Wall-mounted
Installation type	Wall-mounted
Type of control	Electronic
Type of control settings	-
Decor panel options	N/A
Motor location	Integrated motor in hood chimney
Operating Mode	Convertible
Electrical connection rating (W)	255
Current (A)	1,1
Voltage (V)	220-240
Frequency (Hz)	50
Length of Electrical Supply Cord (cm)	150
Plug type	Schuko
Chimney height (mm)	-
Height of product, without chimney (mm)	40
Height of the product	1150
Width of the product	598
Depth of the product	450
Minimum niche height	0
Minimum niche width	0
Niche depth	0
Net weight (kg)	15.6

## TECHNICAL FEATURES

Type of manual control devices	Buttons
Type of automatic control devices	-
Number of motors	1
Total power of the motors (W)	250
Number of speed settings: boost option availability	1
Boost presence	Yes
Maximum output air extraction (m <sup>3</sup> /h)	713
Boost position air extraction (m <sup>3</sup> /h)	713
Maximum output recirculating air (m <sup>3</sup> /h)	330
Boost position output recirculating (m <sup>3</sup> /h)	330
Light Control Type	On/Off
Number of lights	2
Type of lamps used	LED
Total power of the lamps (W)	5
Diameter of air outlet (mm)	150
No-return airflow flap	No
Grease filter material	Washable aluminium
Odour filter	Yes

## ENERGY LABEL

Sound power at min. speed (2010/30/EU)	53
Sound power at max. speed (2010/30/EU)	69
Noise level with boost position (dB(A) re 1 pW)	0