

# W6 D94SB UK

12NC: 859991694270

GTIN (EAN) code: 8003437059162

Whirlpool

SENSING THE DIFFERENCE

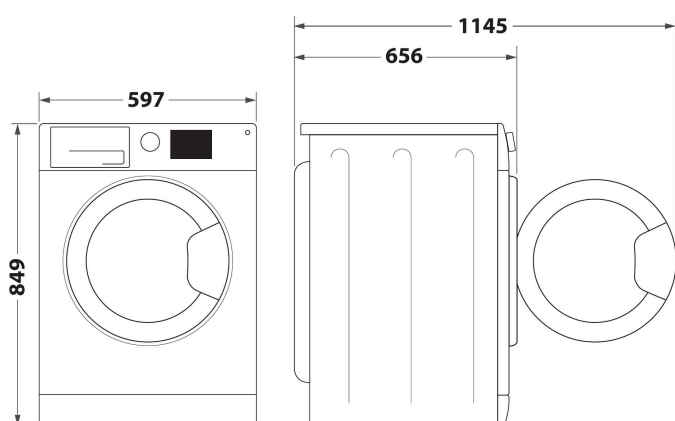

- Energy class A+++
- Drying capacity: 9,0 kg
- Silver finishing
- 6TH Sense Technology
- Heat pump technology
- 3DRY technology
- FreshCare+
- Adjustable Drying Temperature
- Drying time
- Delicates
- Adjustable dryness levels
- Rapid program
- Eco Cotton
- Wool
- Mixed Fabrics Program
- Special big items
- Jeans

## Whirlpool heat pump tumble dryer: freestanding, 9,0kg - W6 D94SB UK

This Whirlpool freestanding Tumble Dryer features: silver color. Outstanding 9,0kg drum capacity, so you will never run out of space. Exclusive 6th SENSE technology that constantly monitors the moisture in the drum, protecting your clothes and providing ideal drying results. Elegant screened door design. Heat pump technology that effectively re-heats the air in the appliance, significantly reducing energy consumption.



### 6th Sense

6th Sense automatically detects the amount of laundry and sets the right drying cycle time, guaranteeing the desired dryness level, with time and energy optimization.



### 3DRYTechnology

The unique 6TH SENSE 3DRY ensures intelligent control of the drying process, whereas 3DRY Technology provides uniform heat distribution inside the drum thanks to multiple flows of warm air. For evenly-dried results also on bulky items.



### FreshCare+

Keep your garments fresh up to 6 hours after the cycle is over\*. Innovative FreshCare+ system takes care of your garments inside the dryer thanks to intelligent delicate temperature control and delicate tumbling action that keep garments fresh and prevent bad odours. FreshCare+ treatment leaves truly fresher clothes and peace of mind - even hours after the end of the cycle. \*FreshCare+ treatment inhibits the proliferation of the main bad odour sources (inside the dryer) up to 6 hours after the drying ends. Not compatible with programmes designed for delicate garments and with extra and cupboard drying levels.



### 9kg capacity

All the space you need. With an outstanding 9kg drum capacity, this Whirlpool Dryer provides all the space you need for your laundry.



### Very quiet

This Whirlpool Dryer is designed to produce very limited noise output.



### Energy Class A+++

Outstanding energy efficiency. With its A+++ energy rating, this Whirlpool Dryer will allow you to enjoy both ideal results and excellent energy consumption.



### Premium design

This Whirlpool Dryer's outstanding design features ensure it will become an eye-catching addition to your home.

# W6 D94SB UK

12NC: 859991694270

GTIN (EAN) code: 8003437059162

# Whirlpool

SENSING THE DIFFERENCE

## MAIN FEATURES

Product group	Dryer
Commercial code	W6 D94SB UK
GTIN (EAN) code	8003437059162
Construction type	Free-standing
Installation type	Free-standing
Removable work top	No
Loading type	Front loader
Main colour of product	Silver
Electrical connection rating (W)	700
Current (A)	10
Voltage (V)	220-240
Frequency (Hz)	50
Length of Electrical Supply Cord (cm)	150
Plug type	UK
Height of the product	849
Width of the product	597
Depth of the product	656
Depth with open door 90 degree (mm)	1145
Net weight (kg)	50.5

## TECHNICAL FEATURES

Automatic programmes	No
Moisture monitoring system	Yes
Adjustable drying temperature	Yes
Progress indicator	Yes
Digital countdown indicator	Yes
Start delay options	Continuous
Start delay time max. (h)	0
Blocked filter indicator	Yes
Full tank indicator	Yes
Quick dry	No
Anti-crease function	Yes
Drum volume (l)	120

## PERFORMANCES

Energy efficiency class - NEW (2010/30/EU)	A+++
Condensation efficiency class - NEW (2010/30/EU)	A
Energy consumption electric dryer, full load - NEW (2010/30/EU)	1,64
Weighted condensation efficiency	91
Weighted annual energy consumption, electric dryer - NEW (2010/30/EU)	194
Capacity cotton (kg) - NEW (2010/30/EU)	9,0
Dryer type	Condenser
Noise level (dB(A) re 1 pW)	62
Standard cotton programme time at full load	210
Standard cotton programme time at partial load	120
Weighted programme time	159
Power consumption in left-on mode - NEW (2010/30/EU)	2,00
Duration of the left-on mode - NEW (2010/30/EU)	15
Power consumption in off-mode - NEW (2010/30/EU)	0,33

**ENERG** Y IJA  
енергия · ενεργεια  
IE IA

**WHIRLPOOL**  
W6 D94SB UK

**A+++**

**A+++**

A+++  
A++  
A+  
A  
B  
C  
D

**194**  
kWh/annum

ENERGIA · ЕНЕРГИЯ · ENERGIA  
ENERGIJA · ENERGY · ENERGIE  
ENERGI

210 min/cycle\*

9,0 kg

62 dB

ABCDEF G

\* λικνωτα · циклуc · portion · zykluc  
tipolozovanje · ciclo · tsiklul  
ohjelma · ciklus · ciklus · ciklus  
ciklu · cyclus · cykl · ciclu  
program · taskompling

392/2012