

WVHF83BB UKIT

12NC: 859991675950

GTIN (EAN) code: 8003437055195

Whirlpool

SENSING THE DIFFERENCE

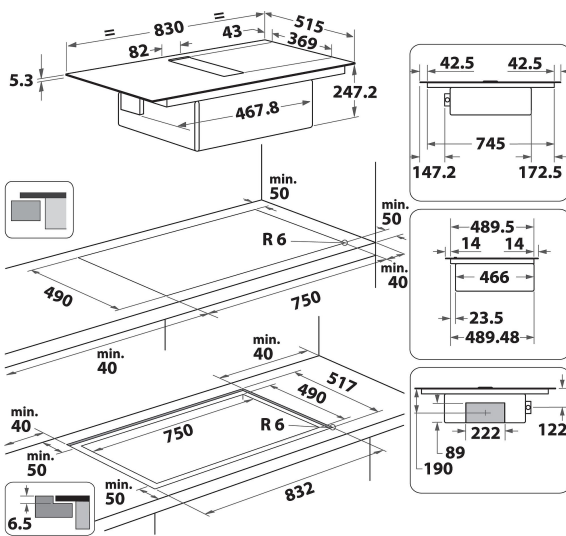

MAIN FEATURES

Product group	Ploča za kuhanje
Construction type	Ugradbeni
Type of control	Front
Type of control settings	-
Number of gas burners	-
Number of electric cooking zones	-
Number of electric plates	-
Number of radiant plates	4
Number of halogen plates	-
Number of induction plates	4
Number of electric warming zones	-
Location of control panel	Front
Basic surface material	Ceramic Glass
Main colour of product	Crna
Electrical connection rating (W)	7400
Gas connection rating (W)	-
Gas type	-
Current (A)	32,2
Voltage (V)	220-240
Frequency (Hz)	50/60
Length of electrical supply cord (cm)	150
Plug type	Ne
Gas connection	-
Width of the product	830
Height of the product	250
Depth of the product	515
Minimum niche height	20
Minimum niche width	560
Niche depth	490
Net weight (kg)	21.5
Automatic programmes	Yes

TECHNICAL FEATURES

Power on indicator	Yes
Number of indicators	5
Type of regulation	Induction
Type of lid	NA
Residual heat indicator	Separate
Main on/off switch	Yes
Safety device	Ne
Timer	Yes

ENERGY LABEL

Energy input	-
--------------	---