

# AKR 811 WH

12NC: 857881115000

GTIN (EAN) code: 8003437982507

**Whirlpool**

SENSING THE DIFFERENCE

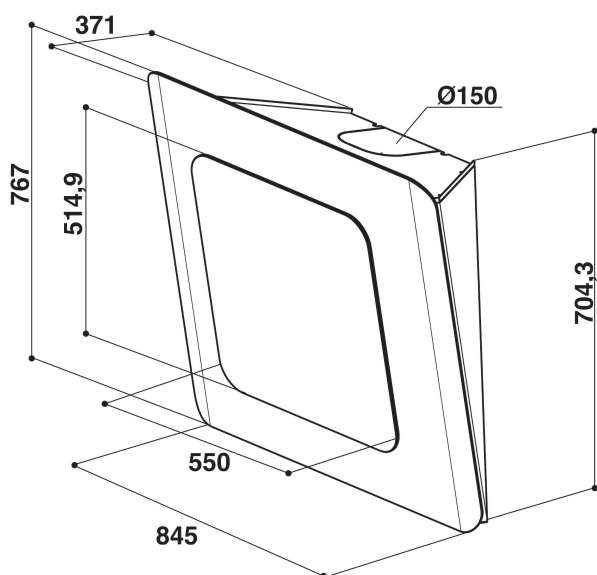

## MAIN FEATURES

Product group	Hood
Colour body	White
Material body	Glass
Colour chimney	-
Material chimney	N/A
Typology	Built-in/Built-under
Installation type	Built-in
Type of control	Electronic
Type of control settings	-
Decor panel options	N/A
Motor location	Integrated motor in hood body
Operating Mode	Recirculating air only
Electrical connection rating (W)	256
Current (A)	1,2
Voltage (V)	220-240
Frequency (Hz)	50/60
Length of Electrical Supply Cord (cm)	150
Plug type	UK
Chimney height (mm)	0
Height of product, without chimney (mm)	767
Height of the product	767
Width of the product	845
Depth of the product	371
Minimum niche height	0
Minimum niche width	0
Niche depth	0
Net weight (kg)	33.8

## TECHNICAL FEATURES

Type of manual control devices	Touch control
Type of automatic control devices	-
Number of motors	1
Total power of the motors (W)	250
Number of speed settings: boost option availability	4
Boost presence	No
Maximum output air extraction (m <sup>3</sup> /h)	596
Boost position air extraction (m <sup>3</sup> /h)	773
Maximum output recirculating air (m <sup>3</sup> /h)	493
Boost position output recirculating (m <sup>3</sup> /h)	604
Light Control Type	On/Off
Number of lights	2
Type of lamps used	LED
Total power of the lamps (W)	6
Diameter of air outlet (mm)	150
No-return airflow flap	No
Grease filter material	Washable aluminium
Odour filter	No

## PERFORMANCES

Sound power at min. speed (2010/30/EU)	-
Sound power at max. speed (2010/30/EU)	-
Noise level with boost position (dB(A) re 1 pW)	0