

# GUIDA RAPIDA



**GRAZIE PER AVER ACQUISTATO UN  
PRODOTTO HOTPOINT - ARISTON**  
Per ricevere un'assistenza più completa,  
registrare il prodotto su  
[www.hotpoint.eu/register](http://www.hotpoint.eu/register)



Scaricare le istruzioni per la sicurezza e le  
istruzioni per l'uso collegandosi al sito  
[docs.hotpoint.eu](http://docs.hotpoint.eu) e seguire la procedura  
indicata sul retro.

**! Leggere attentamente le istruzioni per la sicurezza prima di utilizzare il prodotto**

## DESCRIZIONE PRODOTTO

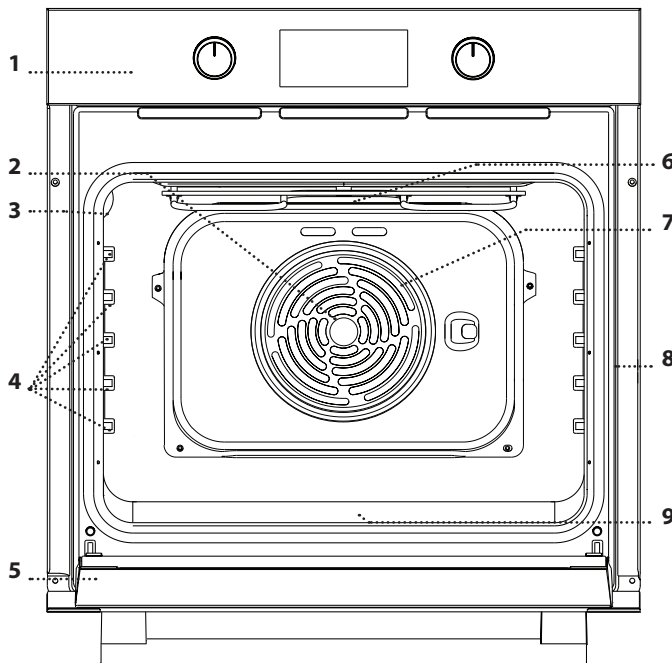

1. Pannello di controllo
2. Ventola
3. Lampada
4. Griglie laterali  
(il livello è indicato sulla parete  
della cavità)
5. Porta
6. Resistenza superiore / Grill
7. Resistenza circolare  
(non visibile)
8. Targhetta matricola  
(da non rimuovere)
9. Resistenza inferiore  
(non visibile)

## PANNELLO DI CONTROLLO

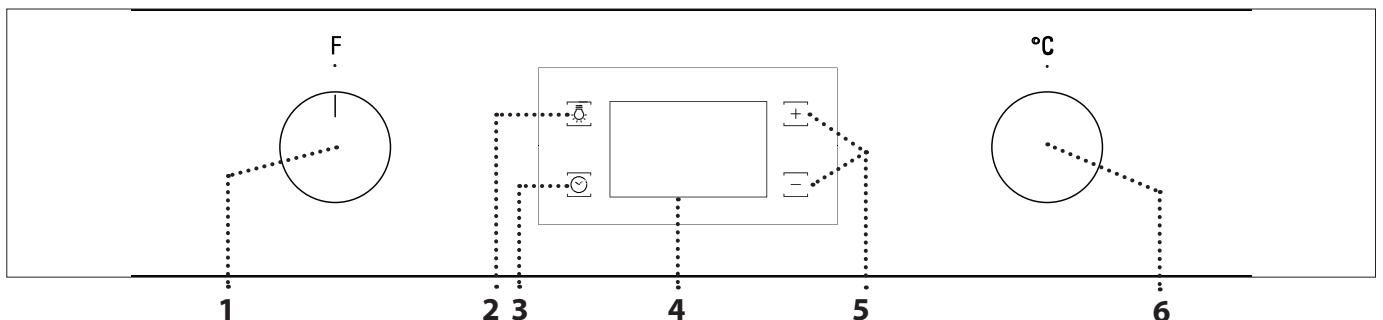

### 1. MANOPOLA DI SELEZIONE

Per accendere il forno  
selezionando una funzione.  
Per spegnere il forno, ruotare sulla  
posizione 0.

### 2. LUCE

A forno acceso, premere per  
accendere o spegnere la luce di  
cavità del forno.

### 3. IMPOSTAZIONE DEL TEMPO

Per accedere alle impostazioni  
della durata di cottura, dell'avvio  
ritardato e del timer. A forno  
spento, per visualizzare l'ora.

### 4. DISPLAY

### 5. TASTI DI REGOLAZIONE

Per modificare le impostazioni di  
durata.

### 6. MANOPOLA TERMOSTATO

Ruotare per selezionare la  
temperatura desiderata attivando  
le funzioni manuali. Su **0** attiva le  
funzioni automatiche.

Nota: le manopole sono a scomparsa;  
premere al centro delle stesse per  
estrarle dalla loro sede.

# Hotpoint

ARISTON

## GRIGLIA

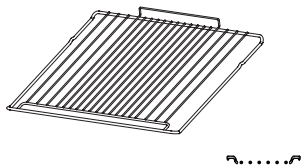

## LECCARDA

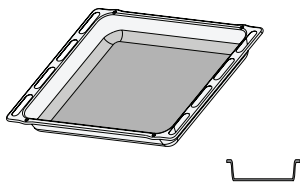

## PIASTRA DOLCI

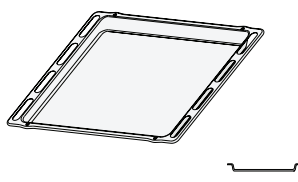

## GUIDE SCORREVOLI

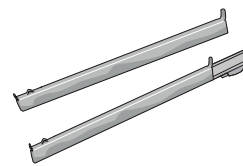

Il numero di accessori può variare a seconda del modello acquistato.  
È possibile acquistare separatamente altri accessori presso il Servizio Assistenza Clienti.

### INSERIRE LA GRIGLIA E ALTRI ACCESSORI

• Inserire la griglia tenendola leggermente inclinata verso l'alto, appoggiando dapprima il lato posteriore rialzato - orientato verso l'alto - sul livello desiderato. In seguito, farla scivolare orizzontalmente sulla griglia laterale fino a fine corsa.

• Gli altri accessori, come leccarda o piastra dolci, si inseriscono orizzontalmente facendoli scivolare sulle griglie laterali.

# FUNZIONI

### — STATICO

Per cuocere qualsiasi tipo di pietanza su un solo ripiano.

### 🌀 TERMOVENTILATO

Per cuocere contemporaneamente su più ripiani (massimo tre) alimenti, anche diversi, che richiedono medesima temperatura di cottura. La funzione permette di cuocere senza trasmissione di odori da un alimento all'altro.

### 🌀 MAXI COOKING

Per cuocere carni di grosse dimensioni (superiori ai 2,5 kg). Si suggerisce di girare la carne durante la cottura per ottenere una brunitura omogenea in entrambi i lati e inumidirla di tanto in tanto per non farla seccare eccessivamente.

### 🌀 PIZZA

Per cuocere diversi tipi e formati di pizza e focaccia. Si consiglia di invertire la posizione delle teglie a metà cottura.

### 🔥 GRILL

Per grigliare costate, spiedini e salsicce, gratinare verdure o dorare il pane. Per la grigliatura delle carni, si consiglia di utilizzare una leccarda per raccogliere il liquido di cottura: posizionarla un livello sotto la griglia e aggiungere 200 ml di acqua potabile.

### 🔥 TURBOGRILL

Per arrostiti grossi pezzi di carne (cosciotti, roast beef, polli). Si consiglia di utilizzare una leccarda per raccogliere il liquido di cottura: posizionarla un livello sotto la griglia e aggiungere 200 ml di acqua potabile.

### 🌀 LIEVITAZIONE

Per ottenere una lievitazione ottimale di impasti dolci o salati. Per preservare la qualità della lievitazione, non attivare la funzione se il forno è ancora caldo dopo un ciclo di cottura.

### 🌀 ECO TERMOVENTILATO\*

Per cuocere arrostiti e arrostiti ripieni su un solo ripiano prevenendo l'eccessiva disidratazione delle pietanze grazie a una ventilazione discontinua e delicata. In questa funzione ECO la luce rimane spenta durante la cottura e può essere riaccesa premendo .

### 🍞<sup>A</sup> PANE AUTO

Questa funzione seleziona automaticamente temperatura e tempo ideali per la cottura del pane. Per ottenere i migliori risultati seguire attentamente la ricetta . Attivare la funzione a forno freddo.

### 🍰<sup>A</sup> DOLCI AUTO

Questa funzione seleziona automaticamente temperatura e tempo ideali per la cottura dei dolci. Attivare la funzione a forno freddo.



### 💧 DIAMOND CLEAN

L'azione del vapore rilasciato durante questo speciale ciclo di pulizia a bassa temperatura permette di rimuovere facilmente sporco e residui di cibo. Versare 200ml di acqua potabile sul fondo del forno, attivando la funzione a forno freddo.







\* Funzione di riferimento per la dichiarazione di efficienza energetica in accordo con il Regolamento europeo 65/2014

# PRIMO UTILIZZO

## 1. IMPOSTARE L'ORA

Alla prima accensione, è necessario impostare l'ora: premere  fino a che sul display non lampeggiano l'icona  e le due cifre relative all'ora.



Utilizzare  o  per impostare l'ora e premere  per confermare. Sul display lampeggiano le due cifre relative ai minuti: utilizzare  o  per impostare l'ora e premere  per confermare.

Note: quando l'icona  lampeggia, ad esempio dopo una prolungata interruzione di corrente, è necessario impostare l'ora.

## 2. RISCALDARE IL FORNO

Un nuovo forno può rilasciare degli odori dovuti alla lavorazione di fabbrica: questo è normale. Prima di cucinare gli alimenti è dunque raccomandato di riscaldare a vuoto il forno per rimuovere ogni odore.

Rimuovere protezioni di cartone o pellicole trasparenti e togliere gli accessori dal forno.

Riscaldare il forno vuoto alla temperatura di 250° per circa 1 ora utilizzando preferibilmente la funzione "Maxi Cooking". Seguire le istruzioni a seguire per impostare correttamente la funzione.

Nota: è opportuno ventilare la stanza durante e dopo il primo utilizzo.

# USO QUOTIDIANO

## 1. SELEZIONARE UNA FUNZIONE

Per selezionare una funzione, ruotare la *manopola di selezione* in corrispondenza del simbolo della funzione desiderata: il display si accende e il forno emette un segnale acustico.



## 2. AVVIARE UNA FUNZIONE

### MANUALE

Per avviare la funzione selezionata, ruotare la *manopola termostato* per impostare la temperatura desiderata.



Note: durante la cottura sarà possibile modificare la funzione ruotando la *manopola di selezione* o regolare la temperatura ruotando la *manopola termostato*.

La funzione non si avvierà fino a quando la manopola termostato sarà su 0°C. Sarà possibile impostare durata, ora di fine cottura (solo se è impostata una durata) e timer.

### AUTOMATICA

Per avviare la funzione automatica ("Pane" o "Dolci") selezionata, mantenere la *manopola termostato* sulla posizione dedicata alle funzioni automatiche (●). Per terminare la cottura, ruotare la *manopola di selezione* in corrispondenza della posizione 0.

Note: sarà possibile impostare ora di fine cottura e timer.

### LIEVITAZIONE

Per avviare la funzione "Lievitazione", ruotare la *manopola termostato* in corrispondenza del simbolo della funzione; se in corrispondenza di temperature differenti, la funzione non si avvierà.

Note: Sarà possibile impostare la durata, l'ora di fine cottura (solo se è impostata una durata) e il timer.

## 3. PRERISCALDAMENTO E CALORE RESIDUO

Una volta avviata la funzione, un segnale acustico e l'icona  lampeggiante sul display segnalano che si è attivata la fase di preriscaldamento.

Al termine di questa fase, un segnale acustico e l'icona  fissa sul display indicheranno che il forno ha raggiunto la temperatura impostata: a questo punto, inserire gli alimenti e procedere alla cottura.

Note: inserire gli alimenti nel forno prima della fine del preriscaldamento può compromettere i risultati di cottura.

Al termine della cottura e con la funzione disattivata, è possibile che l'icona  rimanga visibile sul display per indicare la presenza di calore residuo.

Note: il tempo di spegnimento dell'icona può variare perché dipende da una serie di fattori, come la temperatura ambiente e la funzione utilizzata. In ogni caso, il prodotto può essere considerato spento quando il puntatore della manopola di selezione si trova su "0".



## 4. PROGRAMMARE LA COTTURA



Per programmare la cottura è necessario aver selezionato precedentemente una funzione.

### DURATA



Premere  tante volte fino a che sul display lampeggiano l'icona  e "00:00".





Utilizzare  o  per impostare la durata desiderata, quindi premere  per confermare. Attivare la funzione ruotando la *manopola termostato* in corrispondenza della temperatura desiderata o necessaria: un segnale acustico e il display avviseranno del termine della cottura.

Note: per annullare la durata impostata, premere  tante volte fino a che sul display lampeggia l'icona , quindi utilizzare  per riportare la durata a "00:00".  
La durata impostata include la fase di preriscaldamento.

## PROGRAMMARE L'ORA DI FINE COTTURA / AVVIO RITARDATO

Una volta impostata una durata sarà possibile posticipare l'avvio della funzione, programmandone l'ora di fine: premere  fino a che sul display non lampeggiano l'icona  e l'ora corrente.



Utilizzare  o  per impostare l'ora di fine cottura desiderata e premere  per confermare.  
Attivare la funzione ruotando la *manopola termostato* in corrispondenza della temperatura desiderata o necessaria: la funzione resterà in pausa fino ad avviarsi automaticamente dopo un periodo di tempo calcolato per terminare la cottura all'orario impostato.

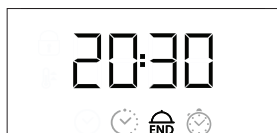

Note: per annullare l'impostazione, spegnere il forno ruotando la *manopola di selezione* sulla posizione "0".

Il ritardo di avvio della funzionalità non è disponibile per le funzioni Grill e Turbo Grill.

## FINE COTTURA

Un segnale acustico e il display avvisano del termine della funzione.

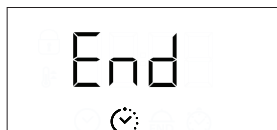



Ruotare la *manopola di selezione* per selezionare una funzione differente o sulla posizione "0" per spegnere il forno.



Nota: se attivo il timer, il display mostrerà la scritta "END" in alternanza al tempo rimanente.

## 5. IMPOSTARE IL TIMER



Questa opzione non interrompe né programma la cottura ma permette di utilizzare il display come contaminuti, sia durante una funzione attiva che quando il forno è spento.

Premere  tante volte fino a che sul display lampeggiano l'icona  e "00:00".



Utilizzare  o  per impostare la durata desiderata e premere  per confermare.

Un segnale acustico avviserà del termine del conto alla rovescia.

Note: per disattivare il timer, premere  tante volte fino a che l'icona  lampeggia, quindi utilizzare  per riportare la durata a "00:00".

## 6. FUNZIONE DIAMOND CLEAN

Per attivare la funzione di pulizia "Diamond clean", dopo aver versato 200 ml di acqua potabile sul fondo della cavità del forno, ruotare la *manopola di selezione* e la *manopola termostato* in corrispondenza dell'icona .



































































Nota: la posizione dell'icona non corrisponde alla temperatura raggiunta durante il ciclo di pulizia.















La funzione si attiva automaticamente: il display mostra il tempo rimanente al termine, alternato alla scritta "dc".



Note: sarà possibile programmare solo l'ora di fine della funzione. La durata è automaticamente impostata a 35 minuti.

# TABELLA DI COTTURA

RICETTA	FUNZIONE	PRE RISCALDARE	TEMPERATURA (°C)	DURATA (MIN)	LIVELLO E ACCESSORI
<b>Torte a lievitazione</b>		Sì	160 - 180	30 - 90	2/3 
		Sì	160 - 180	30 - 90	4  1 
<b>Torte ripiene</b> (cheese cake, strudel, torta di frutta)		Sì	160 - 200	35 - 90	2 
		Sì	160 - 200	40 - 90	4  2 
<b>Biscotti/Tortine</b>		Sì	160 - 180	20 - 45	3 
		Sì	150 - 170	20 - 45	4  2 
		Sì	150 - 170	20 - 45	5  3  1 
<b>Bignè</b>		Sì	180 - 210	30 - 40	3 
		Sì	180 - 200	35 - 45	4  2 
		Sì	180 - 200	35 - 45	5  3  1 
<b>Meringhe</b>		Sì	90	150 - 200	3 
		Sì	90	140 - 200	4  2 
		Sì	90	140 - 200	5  3  1 
<b>Pizza / Focaccia</b>		Sì	190 - 250	15 - 50	1 / 2 
		Sì	190 - 250	20 - 50	4  2 
<b>Pane</b>		-	-	60	2 
<b>Pizze surgelate</b>		Sì	250	10 - 20	3 
		Sì	230 - 250	10 - 25	4  2 
<b>Torte salate</b> (torta di verdura, quiche)		Sì	180 - 200	40 - 55	3 
		Sì	180 - 200	45 - 60	4  2 
		Sì	180 - 200	45 - 60	5  3  1 
<b>Voulevant / Salatini di pasta sfoglia</b>		-	190 - 200	20 - 30	3 
		-	180 - 190	20 - 40	4  2 
		-	180 - 190	20 - 40	5  3  1 

FUNZIONI								
	Statico	Grill	Turbo Griglia	Pizza	Termoventilato	Maxi Cooking	Pane Auto	EcoTermoventilato
ACCESSORI								
	Griglia	Tortiera o teglia su griglia	Leccarda / Teglia su griglia	Leccarda	Leccarda con 200ml di acqua	Piastra Dolci		

RICETTA	FUNZIONE	PRE RISCALDARE	TEMPERATURA (°C)	DURATA (MIN)	LIVELLO E ACCESSORI
<b>Lasagna / Pasta al forno / Cannelloni / Sformati</b>		Sì	190 - 200	45 - 65	2
<b>Agnello / Vitello / Manzo / Maiale 1 kg</b>		Sì	190 - 200	80 - 110	3
<b>Arrosto di maiale con cotenna 2kg</b>		Sì	180 - 190	110 - 150	2
<b>Pollo / Coniglio / Anatra 1 kg</b>		Sì	200 - 230	50 - 100	2
<b>Tacchino / Oca 3 kg</b>		-	190 - 200	100 - 160	2
<b>Pesce al forno / al cartoccio (filetto, intero)</b>		Sì	170 - 190	30 - 50	2
<b>Verdure ripiene (pomodori, zucchine, melanzane)</b>		Sì	180 - 200	50 - 70	2
<b>Pane tostato</b>		-	250	2 - 6	5
<b>Filetti / tranci di pesce</b>		-	230 - 250	20 - 30*	4 3
<b>Salsicce / Spiedini / Costine / Hamburger</b>		-	250	15 - 30*	5 4
<b>Pollo arrosto 1-1,3 kg</b>		Sì	200 - 220	55 - 70**	2 1
<b>Roast beef al sangue 1 kg</b>		Sì	200 - 210	35 - 50**	3
<b>Cosciotto di agnello / Stinchi</b>		Sì	200 - 210	60 - 90**	3
<b>Patate arrosto</b>		Sì	200 - 210	35 - 55**	3
<b>Verdure gratinate</b>		-	200 - 210	25 - 55	3
<b>Carne &amp; Patate</b>		Sì	190 - 200	45 - 100***	4 1
<b>Pesce &amp; Verdure</b>		Sì	180	30 - 50***	4 1
<b>Lasagna &amp; Carne</b>		Sì	200	50 - 100***	4 1
<b>Pasto completo: Crostata (Liv. 5) / Lasagna (Liv. 3) / Carne (Liv. 1)</b>		Sì	180 - 190	40 - 120***	5 3 1
<b>Arrosti / Arrosti ripieni</b>		-	170 - 180	100 - 150	2

La durata indicata non comprende la fase di preriscaldamento: si consiglia di inserire gli alimenti nel forno e di impostare la durata della cottura solo al raggiungimento della temperatura desiderata.

\* Ruotare il cibo a metà cottura.

\*\* Ruotare il cibo a due terzi di cottura se necessario.

\*\*\* La durata è approssimata: le pietanze possono essere tolte dal forno in tempi differenti secondo preferenza.

Scaricare le istruzioni per l'uso da [docs.hotpoint.eu](https://docs.hotpoint.eu) per consultare la tabella delle ricette testate, compilata per gli istituti di valutazione secondo la norma IEC 60350-1.

FUNZIONI								
	Statico	Grill	Turbo Grill	Pizza	Termoventilato	Maxi Cooking	Pane Auto	EcoTermoventilato
ACCESSORI								
	Griglia	Tortiera o teglia su griglia	Leccarda / Teglia su griglia	Leccarda	Leccarda con 200ml di acqua	Piastra Dolci		

**Non usare pulitrici a getto di vapore.**

**Utilizzare guanti protettivi durante tutte le operazioni.**

**Eseguire le operazioni indicate a forno freddo.**

**Scollegare l'apparecchio dalla rete elettrica.**



**Non usare pagliette metalliche, panni abrasivi e detersivi abrasivi o corrosivi che possano danneggiare le superfici.**

#### SUPERFICI ESTERNE

- Pulire le superfici con un panno in microfibra umido. Se molto sporche, aggiungere qualche goccia di detersivo neutro. Asciugare con un panno asciutto.
- Non usare detersivi corrosivi o abrasivi. Se inavvertitamente uno di questi prodotti dovesse venire a contatto con le superfici, pulire subito con un panno in microfibra umido.

#### SUPERFICI INTERNE

- Dopo ogni uso, lasciare raffreddare il forno e pulirlo preferibilmente quando è ancora tiepido per rimuovere incrostazioni e macchie dovute a residui di cibo; per asciugare la condensa dovuta alla cottura di alimenti con un elevato contenuto di acqua, usare a forno freddo un panno o una spugna.

- Attivare la funzione "Diamond Clean" per una pulizia ottimale delle superfici interne.
- Per facilitare la pulizia dei vetri è possibile rimuovere e smontare facilmente la porta. 
- Pulire i vetri della porta con detersivi liquidi specifici.
- La resistenza superiore del grill può essere abbassata per pulire la parete superiore del forno. 

#### ACCESSORI

Mettere a bagno gli accessori con detersivo per piatti dopo l'uso, maneggiandoli con guanti da forno, se ancora caldi. I residui di cibo possono essere rimossi con una spazzola per piatti o con una spugna.

### TOGLIERE E RIMONTARE LA PORTA

**1.** Per rimuovere la porta, aprirla completamente e abbassare i fermi fino alla posizione di sblocco.

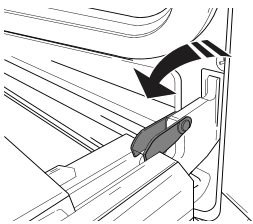

**2.** Chiudere la porta fino a quando è possibile. Prendere saldamente la porta con entrambe le mani, evitando di tenerla per la maniglia. Per estrarla facilmente, continuare a chiuderla e contemporaneamente tirarla verso l'alto (a) finché non esce dalle sedi (b).

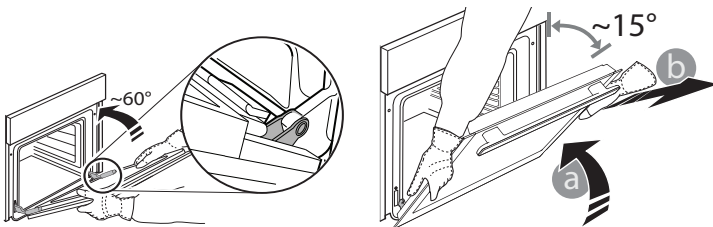

Togliere la porta e appoggiarla su un piano morbido.

**3.** Per rimontare la porta, avvicinarla al forno allineando i ganci delle cerniere alle proprie sedi e ancorare la parte superiore agli alloggiamenti.

**4.** Abbassare la porta e poi aprirla completamente. Abbassare i fermi nella posizione originale: fare attenzione che siano completamente abbassati.

**5.** Provare a chiudere la porta, verificando che sia allineata al pannello di controllo. Se non lo fosse, ripetere tutte le operazioni.

### CLICK TO CLEAN - PULIRE I VETRI

**1.** Dopo aver smontato la porta e averla appoggiata su un ripiano morbido con la maniglia verso il basso, premere contemporaneamente le due clip di fissaggio ed estrarre il profilo superiore della porta tirandolo verso di sé.

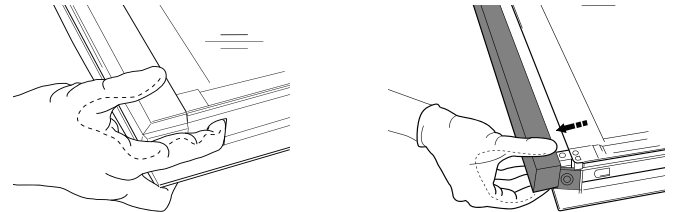

**2.** Sollevare e prendere saldamente il vetro interno con due mani, rimuoverlo e appoggiarlo su un piano morbido prima di eseguire la pulizia.

**3.** Per riposizionare correttamente il vetro interno, fare attenzione che la "R" sia visibile nell'angolo sinistro e che la superficie lucida (non stampata) sia rivolta verso l'alto. Inserire dapprima il lato lungo del vetro indicato dalla "R" nelle sedi di sostegno, quindi abbassarlo in posizione.

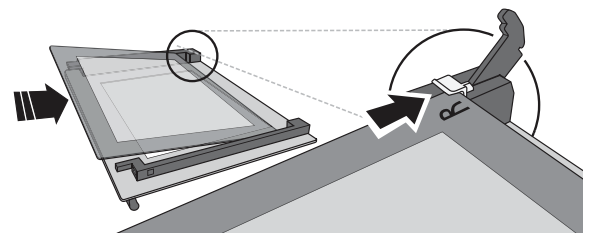

**4.** Rimontare il profilo superiore: un clic indica il corretto posizionamento. Verificare che la tenuta sia salda prima di rimontare la porta.



Problema	Possibile causa	Soluzione
Il forno non funziona	Interruzione di corrente elettrica Disconnessione dalla rete principale	Verificare che ci sia tensione in rete e che il forno sia collegato all'alimentazione elettrica. Spegnerne e riaccendere il forno e verificare se l'inconveniente persiste
Il display mostra la lettera "F" seguita da un numero	Problema software	Contattare il più vicino Servizio Assistenza Clienti e specificare il numero che segue la lettera "F"

## CONSIGLI UTILI



### COME LEGGERE LA TABELLA DI COTTURA

La tabella indica la funzione, gli accessori e il livello migliore da utilizzare per cuocere svariati tipi di cibo. I tempi di cottura si riferiscono all'introduzione del cibo nel forno, escluso il preriscaldamento (dove richiesto). Le temperature e i tempi di cottura sono indicativi e dipendono dalla quantità di cibo e dal tipo di accessori. Utilizzare inizialmente i valori più bassi consigliati e, se il risultato della cottura non è quello desiderato, passare a quelli più alti. Si consiglia di utilizzare gli accessori in dotazione e tortiere o teglie possibilmente in metallo scuro. È possibile utilizzare anche pentole e accessori in pyrex o in ceramica, i tempi di cottura si allungheranno leggermente.

### CUCINARE DIFFERENTI ALIMENTI CONTEMPORANEAMENTE

Utilizzando la funzione "Termoventilato", è possibile cuocere contemporaneamente cibi diversi (ad esempio: pesce e verdure), su ripiani diversi. Estrarre i cibi che richiedono tempi di cottura inferiori e lasciare continuare la cottura per quelli con tempi più lunghi.

### FUNZIONE PANE AUTO

Per ottenere i migliori risultati è opportuno seguire attentamente le indicazioni, rispettando la ricetta per 1000g d'impasto: 600g di farina, 360g di acqua, 11g di sale, 25g di lievito fresco (oppure 2 bustine di lievito in polvere).

Per una lievitazione ottimale, sono necessari circa 90 minuti a temperatura ambiente oppure 60 minuti all'interno del forno attivando la funzione "Lievitazione".

Infornare a forno freddo, versare 1 dl di acqua potabile fredda sul fondo del forno e avviare la funzione "Pane Auto". Al termine della cottura, lasciare riposare su una griglia fino a completo raffreddamento.

### SCHEDA TECNICA

La scheda del prodotto comprensiva dei dati energetici di questo forno può essere scaricata dal sito internet [docs.hotpoint.eu](http://docs.hotpoint.eu)

### COME OTTENERE LE ISTRUZIONI PER L'USO

> Scaricare le istruzioni per l'uso dal sito internet [docs.hotpoint.eu](http://docs.hotpoint.eu) (è possibile usare questo QR Code) indicando il codice commerciale del prodotto.



> In alternativa, contattare il Servizio di Assistenza Clienti

### CONTATTARE IL SERVIZIO ASSISTENZA CLIENTI

I contatti possono essere trovati sul manuale di garanzia. Quando si contatta il Servizio di Assistenza Clienti fornire i codici presenti sulla targhetta matricola del prodotto.

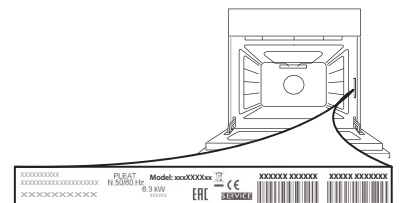

# DAILY REFERENCE GUIDE



## THANK YOU FOR PURCHASING AN HOTPOINT - ARISTON PRODUCT

To receive more comprehensive help and support, please register your product at [www.hotpoint.eu/register](http://www.hotpoint.eu/register)



You can download the Safety Instructions and the Use and Care Guide by visiting our website [docs.hotpoint.eu](http://docs.hotpoint.eu) and following the instructions on the back of this booklet.



**Before using the appliance carefully read the Health and Safety guide.**

## PRODUCT DESCRIPTION

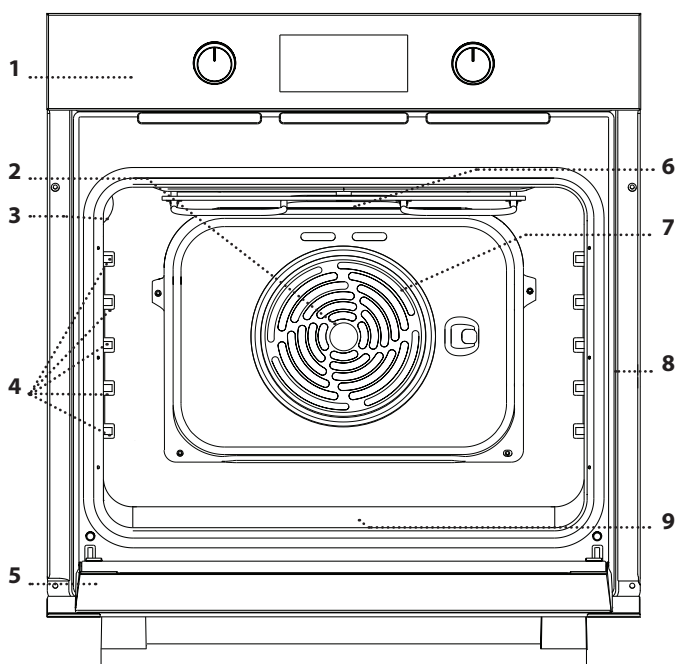

1. Control panel
2. Fan
3. Lamp
4. Shelf guides  
(the level is indicated on the wall of the cooking compartment)
5. Door
6. Upper heating element / grill
7. Circular heating element  
(not visible)
8. Identification plate  
(do not remove)
9. Bottom heating element  
(not visible)

## CONTROL PANEL

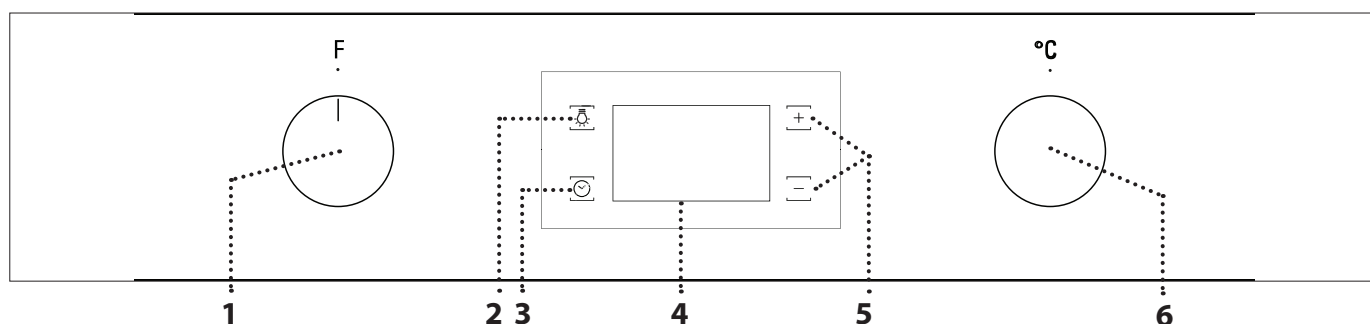

### 1. SELECTION KNOB

For switching the oven on by selecting a function. Turn to the 0 position to switch the oven off.

### 2. LIGHT

With the oven switched on, press to turn the oven compartment lamp on or off.

### 3. SETTING THE TIME

For accessing the cooking time settings, delayed start and timer. For displaying the time when the oven is off.

### 4. DISPLAY

### 5. ADJUSTMENT BUTTONS

For changing the cooking time settings.

### 6. THERMOSTAT KNOB

Turn to select the temperature you require when activating manual functions. Automatic functions use 0.

Please note: All knobs are push-activated knobs. Push down on the centre of the knob to release it from its seating.

# Hotpoint

ARISTON

## WIRE SHELF

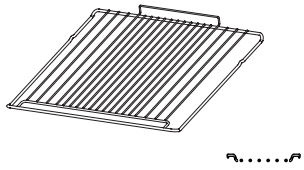

## DRIP TRAY

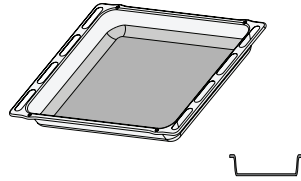

## BAKING TRAY

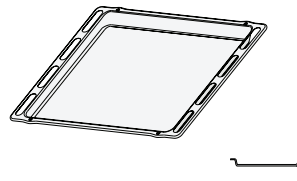

## SLIDING RUNNERS

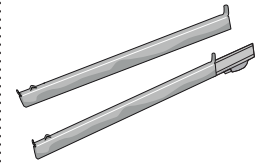

The number of accessories may vary depending on which model is purchased. Other accessories can be purchased separately from the After-sales Service.

## INSERTING THE WIRE SHELF AND OTHER ACCESSORIES

• Insert the wire shelf onto the level you require by holding it tilted slightly upwards and resting the raised rear side (pointing upwards) down first. Next, slide it horizontally along the shelf guide as far as possible.

• The other accessories, such as the drip tray and the baking tray, are inserted horizontally by sliding them along the shelf guides.

# FUNCTIONS



### CONVECTION

For cooking any kind of dish on one shelf only.



### FORCED AIR

For cooking different foods that require the same cooking temperature on several shelves (maximum three) at the same time. This function can be used to cook different foods without odours being transferred from one food to another.



### MAXI COOKING

For cooking large joints of meat (above 2.5 kg). We recommend turning the meat over during cooking to ensure that both sides brown evenly. We also recommend basting the joint every so often to prevent it from drying out excessively.



### PIZZA

For baking different types and sizes of pizza and bread. It is a good idea to swap the position of the baking plates halfway through cooking.



### GRILL

For grilling steaks, kebabs and sausages, cooking vegetables au gratin or toasting bread. When grilling meat, we recommend using a drip tray to collect the cooking juices: Position the tray on any of the levels below the wire shelf and add 200 ml of drinking water.



### TURBO GRILL

For roasting large joints of meat (legs, roast beef, chicken). We recommend using a drip tray to collect the cooking juices: position the pan on any of the levels below the wire shelf and add 200 ml of drinking water.



### RISING

For helping sweet or savoury dough to rise effectively. To maintain the quality of proving, do not activate the function if the oven is still hot following a cooking cycle.



### ECO FORCED AIR\*

For cooking roasts and stuffed roasting joints on a single shelf. Food is prevented from drying out excessively by gentle, intermittent air circulation. When this ECO MODE function is in use, the light will remain switched off during cooking but can be switched on again by pressing .



### <sup>A</sup> BREAD AUTO

This function automatically selects the ideal temperature and baking time for bread. For best results, carefully follow the recipe . Activate the function when the oven is cold.



### <sup>A</sup> PASTRY AUTO

This function automatically selects the ideal temperature and baking time for cakes. Activate the function when the oven is cold.





### DIAMOND CLEAN

The action of the steam released during this special low-temperature cleaning cycle allows dirt and food residues to be removed with ease. Pour 200 ml of drinking water on the bottom of the oven and only activate the function when the oven is cold.







\* Function used as reference for the energy efficiency declaration in accordance with Regulation (EU) No. 65/2014

# USING THE APPLIANCE FOR THE FIRST TIME

## 1. SETTING THE TIME

You will need to set the time when you switch on the appliance for the first time: press  until the  icon and the two digits for the hour start flashing on the display.



Use  or  to set the hour and press  to confirm. The two digits for the minutes will start flashing. Use  or  to set the minutes and press  to confirm.

Please note: When the  icon is flashing, for example following lengthy power outages, you will need to reset the time.

## 2. REHEAT THE OVEN

A new oven may release odours that have been left behind during manufacturing: this is completely normal.

Before starting to cook food, we therefore recommend heating the oven with it empty in order to remove any possible odours.

Remove any protective cardboard or transparent film from the oven and remove any accessories from inside it.

Heat the oven to 250 ° C for about one hour, preferably using the “Maxi Cooking” function. The oven must be empty during this time. Follow the instructions for setting the function correctly.

Please note: It is advisable to air the room after using the appliance for the first time.

## DAILY USE

### 1. SELECT A FUNCTION

To select a function, turn the *selection knob* to the symbol for the function you require: the display will light up and an audible signal will sound.



### 2. ACTIVATE A FUNCTION

#### MANUAL

To start the function you have selected, turn the *thermostat knob* to set the temperature you require.

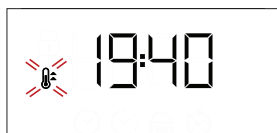

Please note: During cooking you can change the function by turning the *selection knob* or adjust the temperature by turning the *thermostat knob*.

The function will not start if the thermostat knob is on 0 °C. You can set the cooking time, cooking end time (only if you set a cooking time) and a timer.

#### AUTOMATIC

To start the automatic function you have selected (“Bread” or “Dessert”), keep the *thermostat knob* at the position for automatic functions (  ).

To finish cooking, turn the *selection knob* to position 0.

Please note: You can set the cooking end time and timer.

#### RISING

To start the “Rising” function, turn the *thermostat knob* to the relevant symbol; if the oven is set to a different temperature, the function will not start.

Please note: You can set the cooking time, cooking end time (only if you set a cooking time) and a timer.

### 3. PREHEATING AND RESIDUAL HEAT

Once the function starts, an audible signal and a flashing icon  on the display indicate that the preheating phase has been activated.

At the end of this phase, an audible signal and the fixed icon  on the display will indicate that the oven has reached the set temperature: at this point, place the food inside and proceed with cooking.

Please note: Placing the food in the oven before preheating has finished may have an adverse effect on the final cooking result.



After cooking and with the function deactivated, the icon  may continue to remain visible on the display even after the cooling fan has switched off to indicate that there is residual heat in the compartment.

Please note: The time after which the icon switches off varies because it depends on a series of factors such as ambient temperature and function used. In any case, the product should be considered to be off when the pointer on the selection knob is at “0”.



### 4. PROGRAMMING COOKING

You will need to select a function before you can start programming cooking.



#### DURATION

Keep pressing  until the  icon and “00:00” start flashing on the display.



Use  or  to set the cooking time you require, then press  to confirm.



Activate the function by turning the *thermostat knob* to the temperature you require: an audible signal will sound and the display will indicate that cooking is complete.

Notes: To cancel the cooking time you have set, keep pressing  until the  icon starts flashing on the display, then use  to reset the cooking time to “00:00”. This cooking time includes a preheating phase.

## PROGRAMMING THE END COOKING TIME/DELAYED START

After a cooking time has been set, starting the function can be delayed by programming its end time: press  until the  icon and the current time start flashing on the display.



Use  or  to set the time you want cooking to end and press  to confirm.

Activate the function by turning the *thermostat knob* to the temperature you require: the function will remain paused until it starts automatically after the period of time that has been calculated in order for cooking to finish at the time you have set.



Please note: To cancel the setting, switch the oven off by turning the *selection knob* to position **0**.

Delay to start functionality is not available for Grill and Turbo Grill functions.

## END OF COOKING

An audible signal will sound and the display will indicate that the function has finished.





Turn the *selection knob* to select a different function or to position **0** to switch the oven off.



Please note: If the timer is active, the display will show "END" alternately with the remaining time.

## 5. SETTING THE TIMER

This option does not interrupt or program cooking but allows you to use the display as a timer, either during while a function is active or when the oven is off.

Keep pressing  until the  icon and "00:00" start flashing on the display.



Use  or  to set the time you require and press  to confirm.

An audible signal will sound once the timer has finished counting down the selected time.

Notes: To cancel the timer, keep pressing  until the  icon starts flashing, then use  to reset the time to "00:00".

## 6. DIAMOND CLEAN FUNCTION

To activate the "Diamond Clean" cleaning function, pour 200 ml of drinking water into the bottom of the oven, then turn the *selection knob* and the *thermostat knob* to the .



































































Please note: The position of the icon does not correspond to the temperature reached during the cleaning cycle.

The function will activate automatically: the display shows the time remaining to the end, alternating with "DC".









Please note: It is only possible to programme the end time of this function. The duration is automatically set to 35 minutes.

# COOKING TABLE

RECIPE	FUNCTION	PREHEAT	TEMPERATURE (°C)	DURATION (MIN)	LEVEL AND ACCESSORIES
<b>Leavened cakes</b>		Yes	160-180	30-90	2/3 
		Yes	160 - 180	30 - 90	4  1 
<b>Filled cake</b> (cheese cake, strudel, fruit pie)		Yes	160-200	35-90	2 
		Yes	160-200	40-90	4  2 
<b>Biscuits/tartlets</b>		Yes	160-180	20-45	3 
		Yes	150 - 170	20 - 45	4  2 
		Yes	150 - 170	20-45	5  3  1 
<b>Choux buns</b>		Yes	180 - 210	30-40	3 
		Yes	180-200	35-45	4  2 
		Yes	180-200	35-45	5  3  1 
<b>Meringues</b>		Yes	90	150 - 200	3 
		Yes	90	140 - 200	4  2 
		Yes	90	140 - 200	5  3  1 
<b>Pizza/bread</b>		Yes	190-250	15-50	1 / 2 
		Yes	190-250	20-50	4  2 
<b>Bread</b>		-	-	60	2 
<b>Frozen pizza</b>		Yes	250	10 - 20	3 
		Yes	230 - 250	10 -25	4  2 
<b>Salty cakes</b> (vegetable pie, quiche)		Yes	180-200	40-55	3 
		Yes	180-200	45 - 60	4  2 
		Yes	180-200	45 - 60	5  3  1 
<b>Vols-au-vents/puff pastry crackers</b>		-	190-200	20-30	3 
		-	180-190	20-40	4  2 
		-	180-190	20-40	5  3  1 

FUNCTIONS								
	Conventional	Grill	Turbo Grill	Pizza	Forced Air	Maxi Cooking	Bread Auto	Eco Forced Air

ACCESSORIES						
	Wire shelf	Baking dish or baking tray on the wire shelf	Drip tray/baking tray on the wire shelf	Drip tray	Drip tray with 200 ml of water	Baking tray

RECIPE	FUNCTION	PREHEAT	TEMPERATURE (°C)	DURATION (MIN)	LEVEL AND ACCESSORIES
<b>Lasagna/baked pasta/cannelloni/flans</b>		Yes	190 - 200	45 - 65	2
<b>Lamb / veal / beef / pork</b> 1 kg		Yes	190 - 200	80 - 110	3
<b>Roast pork with crackling</b> 2 kg		Yes	180-190	110-150	2
<b>Chicken / rabbit / duck</b> 1 kg		Yes	200 - 230	50 - 100	2
<b>Turkey/goose</b> 3 kg		-	190-200	100 - 160	2
<b>Baked Whole Fish</b> (fillet, whole)		Yes	170 - 190	30 - 50	2
<b>Stuffed vegetables</b> (tomatoes, courgettes, aubergines)		Yes	180-200	50 - 70	2
<b>Toasted bread</b>		-	250	2 - 6	5
<b>Fish fillets/slices</b>		-	230 - 250	20 - 30*	4 3
<b>Sausages/kebabs/spare ribs/hamburgers</b>		-	250	15 - 30*	5 4
<b>Roast chicken</b> 1-1.3 kg		Yes	200 - 220	55 - 70**	2 1
<b>Roast beef rare</b> 1 kg		Yes	200 - 210	35 - 50**	3
<b>Leg of lamb/knuckle</b>		Yes	200 - 210	60 - 90**	3
<b>Roast potatoes</b>		Yes	200 - 210	35 - 55**	3
<b>Vegetable gratin</b>		-	200 - 210	25 - 55	3
<b>Meat and potatoes</b>		Yes	190-200	45 - 100***	4 1
<b>Fish and vegetables</b>		Yes	180	30 - 50***	4 1
<b>Lasagne and meat</b>		Yes	200	50 - 100***	4 1
<b>Complete meal: fruit tart</b> (level 5)/ <b>lasagne</b> (level 3)/ <b>meat</b> (level 1)		Yes	180-190	40 - 120***	5 3 1
<b>Roast meat/stuffed roasting joints</b>		-	170 - 180	100 - 150	2

The time indicated does not include the preheating phase: we recommend placing the food in the oven and setting the cooking time only after the required temperature has been reached.

\* Turn food halfway through cooking.

\*\* Turn food two-thirds of the way through cooking (if necessary).

\*\*\* Estimated length of time: dishes can be removed from the oven at different times depending on personal preference.

Download the Use and Care Guide from [docs.hotpoint.eu](http://docs.hotpoint.eu) for the table of tested recipes, compiled for the certification authorities in accordance with the standards IEC and IEC 60350-1.

FUNCTIONS								
	Conventional	Grill	Turbo Grill	Pizza	Forced Air	Maxi Cooking	Bread Auto	Eco Forced Air
ACCESSORIES								
	Wire shelf	Baking dish or baking tray on the wire shelf	Drip tray/baking tray on the wire shelf	Drip tray	Drip tray with 200 ml of water	Baking tray		

# MAINTENANCE AND CLEANING



Download the Use and Care Guide from [docs.hotpoint.eu](https://docs.hotpoint.eu) for more information

**Do not use steam cleaning equipment.**

**Use protective gloves during all operations.**

**Carry out the required operations with the oven cold.**

**Disconnect the appliance from the power supply.**

**Do not use wire wool, abrasive scourers or abrasive/corrosive cleaning agents, as these could damage the surfaces of the appliance.**

## EXTERIOR SURFACES

- Clean the surfaces with a damp microfibre cloth. If they are very dirty, add a few drops of pH-neutral detergent. Finish off with a dry cloth.
- Do not use corrosive or abrasive detergents. If any of these products inadvertently comes into contact with the surfaces of the appliance, clean immediately with a damp microfibre cloth.

## INTERIOR SURFACES

- After every use, leave the oven to cool and then clean it, preferably while it is still warm, to remove any deposits or stains caused by food residues. To dry any condensation that has formed as a result of cooking foods with a high water content, let the oven to cool completely and then wipe it with a cloth or sponge.

- Activate the "Diamond Clean" function for optimum cleaning of the internal surfaces.
- The door can be easily removed and refitted to facilitate cleaning of the glass.
- Clean the glass in the door with a suitable liquid detergent.
- The top heating element of the grill can be lowered to clean the upper panel of the oven.

## ACCESSORIES

Soak the accessories in a washing-up liquid solution after use, handling them with oven gloves if they are still hot. Food residues can be removed using a washing-up brush or a sponge.

## REMOVING AND REFITTING THE DOOR

**1.** To remove the door, open it fully and lower the catches until they are in the unlock position.

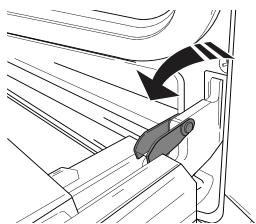

**2.** Close the door as much as you can. Take a firm hold of the door with both hands – do not hold it by the handle. Simply remove the door by continuing to close it while pulling it upwards (a) at the same time until it is released from its seating (b).

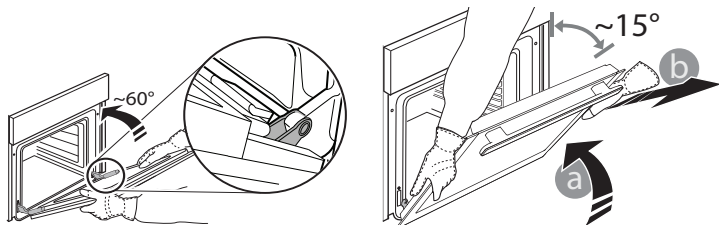

Put the door to one side, resting it on a soft surface.

**3.** Refit the door by moving it towards the oven, aligning the hooks of the hinges with their seating and securing the upper part onto its seating.

**4.** Lower the door and then open it fully. Lower the catches into their original position: make sure that you lower them down completely.

**5.** Try closing the door and check to make sure that it lines up with the control panel. If it does not, repeat the steps above.

## CLICK TO CLEAN - CLEANING THE GLASS

**1.** After removing the door and resting it on a soft surface with the handle downwards, simultaneously press the two retaining clips and remove the upper edge of the door by pulling it towards you.

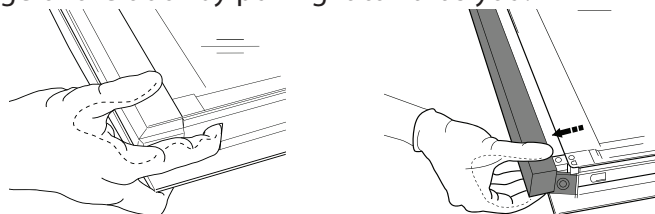

**2.** Lift and firmly hold the inner glass with both hands, remove it and place it on a soft surface before cleaning it.

**3.** To correctly reposition the inner glass, make sure that the "R" is visible in the left-hand corner and the clear surface (not printed) is facing up. First insert the long side of the glass indicated by "R" into the support seats, then lower it into position.

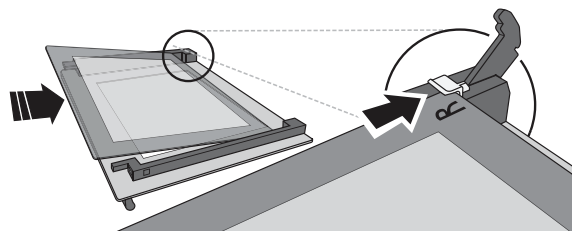

**4.** Refit the upper edge: a click will indicate correct positioning. Make sure the seal is secure before refitting the door.

Problem	Possible cause	Solution
The oven does not work	Power cut Disconnection from the mains	Check for the presence of mains electrical power and whether the oven is connected to the electricity supply. Turn off the oven and restart it to see if the fault persists
The display shows the letter "F" followed by a number	Software problem	Contact you nearest After-sales Service Centre and state the letter or number that follows the letter "F"

## USEFUL TIPS



Download the Use and Care Guide from [docs.hotpoint.eu](http://docs.hotpoint.eu) for more information

### HOW TO READ THE COOKING TABLE

The table lists the best function, accessories and level to use to cook different types of food. Cooking times start from the moment food is placed in the oven, excluding preheating (where required). Cooking temperatures and times are approximate and depend on the amount of food and the type of accessory used. Use the lowest recommended settings to begin with and, if the food is not cooked enough, then switch to higher settings. Use the accessories supplied and preferably dark-coloured metal cake tins and baking trays. You can also use Pyrex or stoneware pans and accessories, but bear in mind that cooking times will be slightly longer.

### COOKING DIFFERENT FOODS AT THE SAME TIME

Using the "Forced Air" function, you can cook different foods which require the same cooking temperature at the same time (for example: fish and vegetables), using different shelves. Remove the food which requires a shorter cooking time and leave the food which requires a longer cooking time in the oven.

### BREAD AUTO FUNCTION

For best results you should carefully follow the instructions, using the recipe for mixing 1000 g of dough: 600 g of flour, 360 g of water, 11 g of salt, 25 g of fresh yeast (or two packets of yeast powder).

For optimal rising, allow about 90 minutes at room temperature or 60 minutes in the oven using the "Proving" function.

Put the dough into the (cold) oven, pour 100 cc of cold drinking water on to the bottom of the oven and activate the "Bread Auto" function. After cooking, leave the dough to stand on a wire shelf until completely cooled.

### PRODUCT FICHE

The product fiche with energy data of this appliance can be downloaded from the website [docs.hotpoint.eu](http://docs.hotpoint.eu)

### HOW TO OBTAIN THE USE AND CARE GUIDE

> Download the Use and Care Guide from our website [docs.hotpoint.eu](http://docs.hotpoint.eu) (you can use this QR Code), specifying the product's commercial code.



> Alternatively, contact our Client After-sales Service

### CONTACTING OUR AFTER-SALES SERVICE

You can find our contact details in the warranty manual. When contacting our Client After-sales Service, please state the codes provided on your product's identification plate.

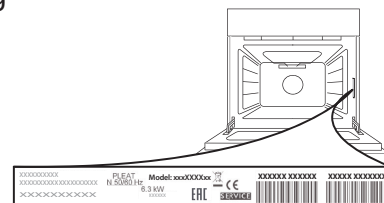

400011708601