

# AKZ9 6230 NB

12NC: 859991530390

GTIN (EAN) code: 8003437833793

**Whirlpool**

SENSING THE DIFFERENCE

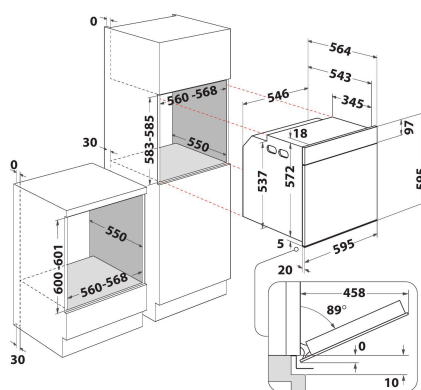

## MAIN FEATURES

Product group	Pećnica
Commercial code	AKZ9 6230 NB
Main colour of product	Crna
Construction type	Ugradbeni
Type of control	Mechanical and electronic
Type of control settings	-
Brončana	Ne
Which kind of hobs can be controlled?	-
Automatic programmes	Yes
Current (A)	16
Voltage (V)	220-240
Frequency (Hz)	50/60
Length of Electrical Supply Cord (cm)	90
Plug type	Ne
Depth with open door 90 degree (mm)	-
Height of the product	595
Width of the product	595
Depth of the product	564
Minimum niche height	0
Minimum niche width	0
Niche depth	0
Net weight (kg)	33
Usable volume (of cavity)	73
Integrated Cleaning system	Titan
Grids of the cavity	1
Trays	2

## TECHNICAL FEATURES

Timer	Yes
Time control	Electronic
Time-setting options	Start and Stop
Safety device	-
Interior light	Yes
Number of interior lights of the cavity	1
Position of interior lights of the cavity	Rear
Oven guides of the cavity	Telescopic
Probe of the cavity	Ne

## ENERGY LABEL

Energy input	Electric
Type of energy of the cavity	Električna energija
Energy efficiency class - NEW (2010/30/EU)	A+
Energy consumption per cycle conventional - NEW (2010/30/EU)	0.91
Energy consumption per cycle forced air convection - NEW (2010/30/EU)	0.70