

ACM 847/BA

12NC: 859991007370

GTIN (EAN) code: 8003437826078

Whirlpool

SENSING THE DIFFERENCE

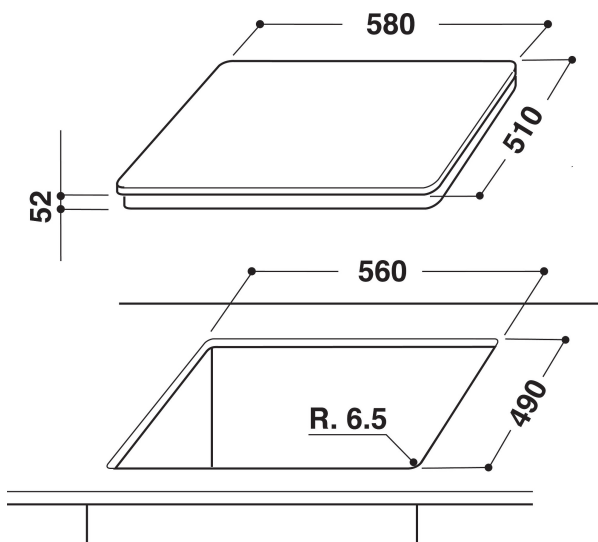

MAIN FEATURES

Product group	Ploča za kuhanje
Construction type	Ugradbeni
Type of control	Electronic
Type of control settings	-
Number of gas burners	0
Number of electric cooking zones	4
Number of electric plates	0
Number of radiant plates	0
Number of halogen plates	0
Number of induction plates	4
Number of electric warming zones	0
Location of control panel	Front
Basic surface material	Glass
Main colour of product	Crna
Electrical connection rating (W)	8000
Gas connection rating (W)	0
Current (A)	32,2
Voltage (V)	230
Frequency (Hz)	50/60
Length of Electrical Supply Cord (cm)	120
Plug type	Ne
Gas connection	-
Width of the product	580
Height of the product	56
Depth of the product	510
Minimum niche height	30
Minimum niche width	560
Niche depth	490
Net weight (kg)	11.5
Automatic programmes	Yes

TECHNICAL FEATURES

Power on indicator	Yes
Number of indicators	4
Type of regulation	Inductor
Type of lid	Without
Residual heat indicator	Separate
Main on/off switch	Yes
Safety device	-
Timer	Yes

ENERGY LABEL

Energy input	Electric
--------------	----------