

# **INSTRUCTIONS FOR USE**

**PRODUCT DESCRIPTION**

**CONTROLS**

**BEFORE USING THE APPLIANCE**

**SAFEGUARDING THE ENVIRONMENT**

**PRECAUTIONS AND GENERAL  
RECOMMENDATIONS**

**HOW TO OPERATE THE REFRIGERATOR  
COMPARTMENT**

**HOW TO OPERATE THE FREEZER  
COMPARTMENT**

**HOW TO DEFROST AND CLEAN THE  
APPLIANCE**

**TROUBLESHOOTING GUIDE**

**AFTER-SALES SERVICE**

**INSTALLATION**

**ELECTRICAL CONNECTION**

# PRODUCT DESCRIPTION

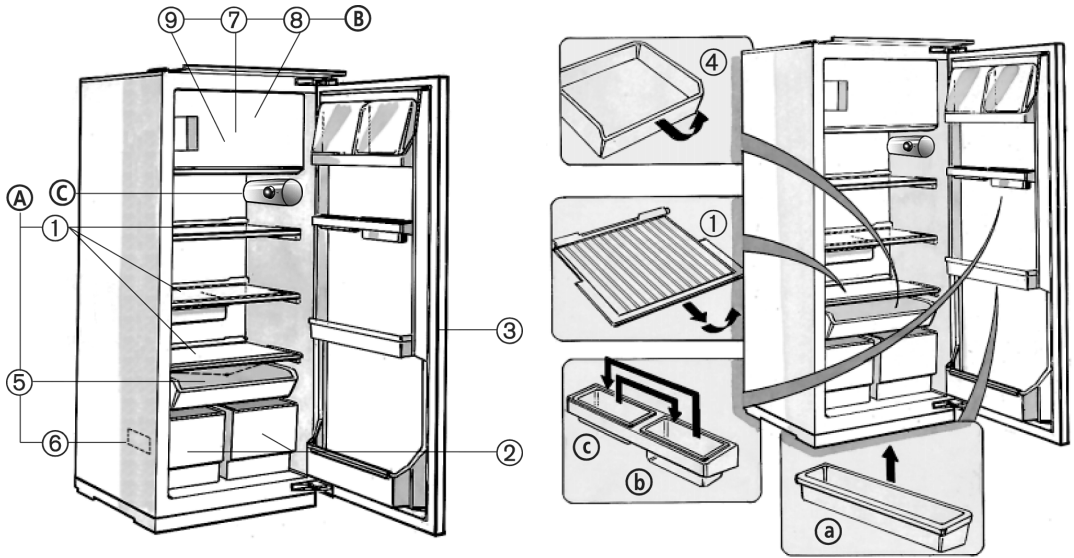

- A) Refrigerator compartment**  
(for storage of fresh food and beverages)
1. Shelves (partly height adjustable)
  2. Crispers
  3. Refrigerator inner door with:  
(if supplied)
    - a. Adjustable door trays
    - b. Top door tray
    - c. Bottom door tray
  4. Drawer (telescopic extraction) (if supplied)
  5. Pull-out defrost water drain
  6. Rating plate

- B) Freezer compartment (if supplied)**  
(marked with the symbol **\*\*\*** **\* \*\*** for storing fresh food, frozen food and making ice cubes)
7. Grid (not shown in the figure, if available)
  8. Freezer section
  9. Ice cube trays
- C) Controls**

# CONTROLS

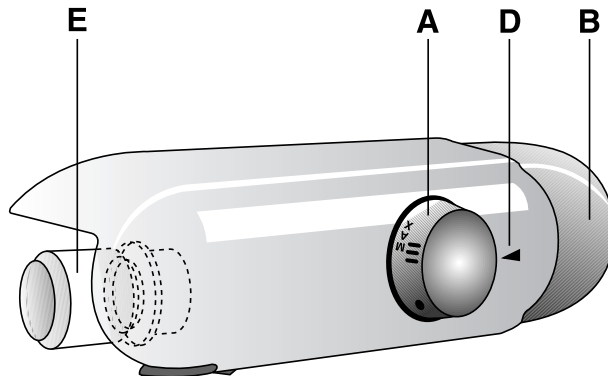

- A.** Thermostat knob  
**B.** Light switch

- D.** Thermostat control reference  
**E.** Light bulb (max 15 W)

# BEFORE USING THE APPLIANCE

- Your new appliance is designed to be used in the household and similar applications such as:
  - kitchen areas in shops, offices and other working environments
  - farm houses
  - by clients in hotels, motels, residences, bed & breakfasts.

**To ensure best use of your appliance, carefully read the operating instructions which contain a description of the product and useful advice.**

**Keep these instructions for future reference.**

1. After unpacking the appliance, make sure it is not damaged and that the door closes properly. Any damage must be reported to the dealer within 24 hours of delivery of the appliance.
2. Wait at least two hours before switching the appliance on in order to ensure that the refrigerant circuit is fully efficient.
3. Installation and electrical connection must be carried out by a qualified technician according to the manufacturer's instructions and in compliance with local safety regulations.
4. Clean the inside of the appliance before using it.

# SAFEGUARDING THE ENVIRONMENT

## 1. Packaging

The packing material is 100% recyclable and bears the recycling symbol. For disposal, comply with local regulations. Keep the packing materials (plastic bags, polystyrene parts, etc.) out of the reach of children, as they are a potential source of danger.

## 2. Scrapping/Disposal

The appliance is manufactured using recyclable material.

This appliance is marked in compliance with European Directive 2002/96/EC on Waste Electrical and Electronic Equipment (WEEE). By ensuring the correct disposal of this appliance, you can help prevent potentially negative consequences for the environment and health.

The symbol  on the appliance, or on the accompanying documents, indicates that this appliance should not be treated as domestic waste but must be taken to a special collection centre for the recycling of electrical and electronic equipment.

When scrapping the appliance, make it unusable by cutting off the power cable and removing the doors and shelves so that children cannot easily climb inside and become trapped.

Scrap the appliance in compliance with local regulations on waste disposal, taking it to a special collection centre; do not leave the appliance unattended even for a few days, since it is a potential source of danger for children. For further information on the treatment, recovery and recycling of this product, contact your competent local office, the household waste collection service or the shop where you purchased the appliance.

## Information:

This appliance does not contain CFCs. The refrigerant circuit contains R134a (HFC) or R600a (HC) (see the rating plate inside the appliance).

Appliances with Isobutane (R600a): isobutane is a natural gas with low environmental. Caution is required, however, since isobutane is flammable. Therefore, it is essential to ensure that refrigerant pipelines are not damaged.

This product may contain Fluorinated Greenhouse Gases covered by the Kyoto Protocol; the refrigerant gas is inside a hermetically sealed system.

Refrigerant gas: R134a has a Global Warming Potential of (GWP) 1300.

## Declaration of conformity

This appliance has been designed for preserving food and is manufactured in compliance with Regulation (CE) No. 1935/2004.



This appliance has been designed, manufactured and marketed in compliance with:

- safety objectives of the "Low Voltage" Directive 2006/95/CE (which replaces 73/23/CEE and subsequent amendments);
- the protection requirements of Directive "EMC" 2004/108/CE.

Electrical safety of the appliance can only be guaranteed if it is correctly connected to an approved earthing system.



# PRECAUTIONS AND GENERAL RECOMMENDATIONS

## INSTALLATION

- The appliance must be handled and installed by two or more persons.
- Be careful not to damage the floors (e.g. parquet) when moving the appliance.
- During installation, make sure the appliance does not damage the power cable.
- Make sure the appliance is not installed near a heat source.
- To guarantee adequate ventilation, leave a space on both sides and above the appliance and follow the installation instructions.
- Keep the appliance ventilation openings free.
- Do not damage the appliance refrigerant circuit pipes.
- Install and level the appliance on a floor strong enough to take its weight and in a place suitable for its size and use.
- Install the appliance in a dry, well ventilated place. The appliance is designed to operate in areas where the temperature comes within the following ranges, according to the climatic class given on the rating plate.  
The appliance may not work properly if it is left for a long time at a temperature outside the specified range.

Climatic Class	Amb. temp. (°C)	Amb. temp. (°F)
SN	From 10 to 32	From 50 to 90
N	From 16 to 32	From 61 to 90
ST	From 16 to 38	From 61 to 100
T	From 16 to 43	From 61 to 110

- Make sure the voltage specified on the rating plate corresponds to that of your home.
- Do not use single/multi adapters or extension cords.
- For the water connection, use the pipe supplied with the new appliance; do not reuse that of the previous appliance.
- Power cable modification or replacement must only be carried out by qualified personnel or After-sales Service.
- It must be possible to disconnect the appliance from the power supply by unplugging it or by means of a mains two-pole switch installed upline of the socket.

## SAFETY

- Do not use the appliance to store aerosol cans or receptacles containing propellants or flammable substances.
- Do not store or use petrol, flammable liquids or gas in the vicinity of this or other electrical appliances. The fumes can cause fires or explosions.
- Do not use mechanical, electric or chemical means other than those recommended by the Manufacturer to speed up the defrost process.
- Do not use or place electrical devices inside the appliance compartments if they are not of the type expressly authorised by the Manufacturer.
- This appliance is not intended for use by persons (including children) with reduced physical, sensory or mental capabilities or lack of experience and knowledge, unless they have been given supervision or instruction concerning use of the appliance by a person responsible for their safety.
- To avoid the risk of children becoming trapped and suffocating, do not allow them to play or hide inside the appliance.
- Do not swallow the contents (non-toxic) of the ice packs (in some models).
- Do not eat ice cubes or ice lollies immediately after taking them out of the freezer since they may cause cold burns.

## USE

- Before carrying out any maintenance or cleaning operation, unplug the appliance or disconnect it from the power supply.
- All appliances equipped with an automatic icemaker and water dispenser must be connected to a water supply that only delivers drinking water (with mains water pressure of between 0.17 and 0.81 Mpa (1.7 and 8.1 bar)). Automatic ice-makers and/or water dispensers not directly connected to the water supply must be filled with drinking water only.
- Use the refrigerator compartment only for storing fresh food and the freezer compartment only for storing frozen food, freezing fresh food and making ice cubes.
- Do not store glass containers with liquids in the freezer since they may burst.

**The Manufacturer declines any liability if the above advice and precautions are not respected.**

# HOW TO OPERATE THE REFRIGERATOR COMPARTMENT

This appliance is a refrigerator with a **\*\*\*** star freezer compartment.

**OR** is a refrigerator with a **\*\*** star freezer compartment.

**Optimal appliance performance is obtained at ambient temperatures between +10°C and +38°C.**

## ① Switching on the appliance

Once the power plug is inserted in the mains socket, unless the thermostat (1) is set to symbol ● the inside light switches on each time the door is opened.

Once the temperature has been set – see next chapter – the appliance is ready for use.

## Adjusting the temperature

- To adjust the temperature in the compartment, turn the thermostat control knob:
  - to lower numbers **1-2/MIN** for the **LEAST COLD** internal temperatures;
  - to **3-4/MED** for a **MEDIUM** temperature;
  - to **5-7/MAX** for the **COLDEST** temperature.

Thermostat setting on ●: no operation, no light.

### Note:

The ambient air temperature, frequency of door opening and the position of the appliance can affect internal temperatures. These factors must be taken into account when setting the thermostat.

### Important

- Thermostat adjustment (1) will depend on where the appliance is installed, ambient temperature and frequency of door opening.

## How to use the refrigerator compartment:

③ Position the food as illustrated in the figure:

1. Cooked food
2. Dairy products, preserves, cheese, butter
3. Fish, meat
4. Sliced cold meat
5. Fruit, vegetables, salad
6. Small jars, eggs
7. Tubes, small jars
8. Small bottles
9. Bottles

### Note:

- Cover food to prevent it drying out.
- Hot food must be allowed to cool properly before being placed in the refrigerator.
- Make sure sufficient space is left for air to circulate around the food.

**Defrosting of the refrigerator compartment is completely automatic.**

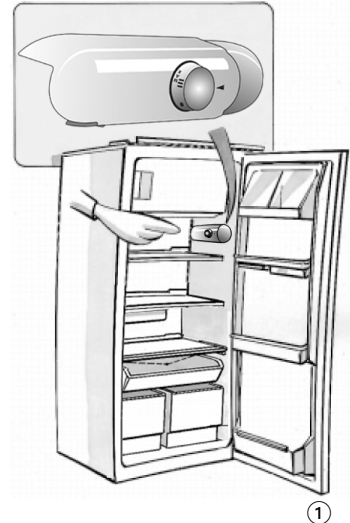

# HOW TO OPERATE THE FREEZER COMPARTMENT

Only for **\*\*\*** or **\* \*\* \*** appliances:

④ Appliances with the symbol **\*\*\*** can be used to store already frozen food.

Appliances with the symbol **\* \*\* \*** can be used to store food for months and also to freeze food. The amount of fresh food (in kg) that can be frozen in 24 hours is indicated on the appliance rating plate (see paragraph "Product description", point 6).

## Freezing food

- Set the thermostat knob (I) to 3-4.
- Arrange the food to be frozen centrally in the **\* \*\* \*** freezer compartment.
- Avoid contact between already frozen food and food that has yet to be frozen (approx. 20 mm distance).
- After 24 hours turn the thermostat knob (I) back to the normal position.

## Important:

Wrap and seal the food in:

- Aluminium foil, cling film, watertight plastic bags, polythene containers with lids or special freezer containers.

## When purchasing frozen food products:

- Ensure that the packaging is not damaged (frozen food in damaged packaging may have deteriorated). If the package is swollen or has damp patches, it may not have been stored under optimal conditions and defrosting may have already begun.
- Transport products in a thermally insulated cool bag.
- When shopping, leave frozen food purchases until last.
- Once at home, place the frozen foods immediately in the freezer.
- If food has defrosted even partially, do not re-freeze it. Consume within 24 hours.
- Avoid subjecting foods to temperature variations. Observe the "best before" date on the package.
- Always observe the storage information on the package.

## Making ice cubes

- Fill the ice cube trays (9) 3/4 with water and place them at the bottom of the freezer compartment.
- Use a spoon handle to remove ice cube trays which stick to the compartment.

**Do not use sharp or pointed instruments.**



# HOW TO DEFROST AND CLEAN THE APPLIANCE

**Before carrying out any maintenance or cleaning operations, unplug the appliance from the mains socket. Defrost the freezer compartment when the ice on the walls reaches a thickness of 3 mm.**

- Remove foodstuffs from the [\*\*\*] or [\*\*\*] freezer and turn the thermostat knob to ●.
  - The frozen food must be wrapped in sheets of newspaper (or a cover) and kept in a cool place.
  - Clean the freezer compartment using a sponge dampened in a solution of lukewarm water and/or neutral detergent.
  - Rinse and dry carefully.
  - Defrosting of the refrigerator compartment is fully automatic.
- ⑤ Clean the defrost water drain outlet regularly in order to ensure that defrost water is removed correctly.

**After cleaning, reconnect the appliance to the power supply.**

**Do not use abrasive products.**

**Prolonged disuse.**

- Empty the compartments.
- Disconnect the appliance from the mains power supply.
- Defrost and clean.
- Leave the doors open to prevent formation of unpleasant odours.

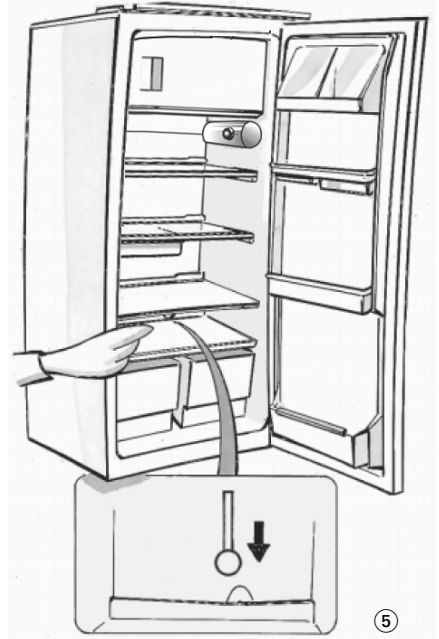

# TROUBLESHOOTING GUIDE

When you hear these noises

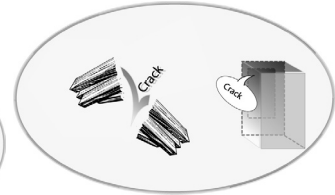
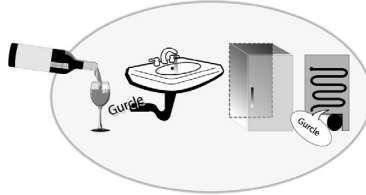
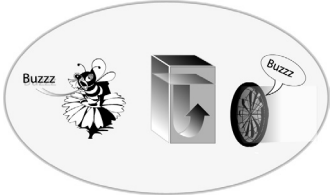
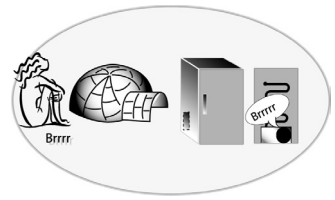
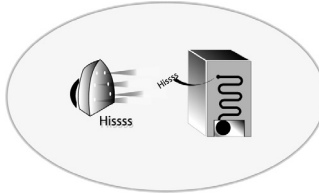
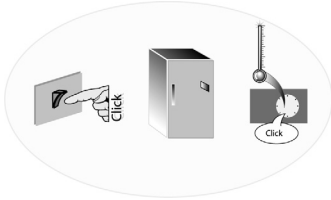

..your appliance is alive!!!

1. **Temperature inside the compartments is not low enough.**
  - Is food preventing the doors from closing properly?
  - Is the thermostat setting correct?
  - Are the air circulation vents blocked?
2. **Temperature inside the refrigerator compartment is too low.**
  - Is the thermostat setting correct?
3. **The appliance is excessively noisy.**
  - Has the appliance been installed correctly?
  - Are the pipes at the back touching or vibrating?
  - It is normal to hear the noise of the refrigerant liquid in circulation.
4. **The appliance is not working?**
  - Is there a power failure?
  - Is the plug properly inserted in the socket?
  - Is the double-pole switch on?
  - Do the household electrical system protection devices work correctly?
  - Is the power cord damaged?
5. **Water collects at the bottom of the refrigerator compartment.**
  - Is the thermostat setting correct?
  - Is the defrost water drain blocked?
6. **The inside light is not working. ⑥ Perform the checks for point 4, and then:**
  - Disconnect the appliance from the mains power supply.
  - If necessary replace the bulb with a new one (220 ÷ 240V, 15 Watt).
  - Removing the light bulb: Unscrew the bulb anticlockwise as shown in the figure



⑥



# AFTER-SALES SERVICE

## Before contacting After-Sales Service:

1. See if you can solve the problem yourself with the help of the “Troubleshooting guide”).
2. Switch the appliance on again to see if the problem has been solved. If it has not, disconnect the appliance from the power supply and wait for about an hour before switching on again.
3. If the problem persists after this course of action, contact After-sales Service.

## Specify:

- the nature of the problem,
- the model,
- the Service number (the number after the word SERVICE on the rating plate on the inside of the appliance),
- your full address,
- your telephone number and area code.

**SERVICE** 0000 000 00000



## Note:

**The direction of door opening can be changed. If this operation is performed by After-sales Service it is not covered by the warranty.**

# INSTALLATION

- ⑧ Install the freezer away from heat sources. Installation in a hot environment, direct exposure to the sun or installation near heat sources (heaters, radiators, cookers) will increase power consumption and should therefore be avoided. If this is not possible, the following minimum distances must be respected:
- 30 cm from coal or paraffin stoves
  - 3 cm from electric stoves.
- Install the appliance in a dry, well-ventilated place.
  - Clean the interior (see “How to defrost and clean the appliance”).
  - Fit the accessories.
  - Check the door seal is not damaged or deformed, especially after installation or reversal of door opening.

## Electrical connection

- Ensure that the voltage indicated on the appliance rating plate corresponds to the domestic supply voltage.
- Regulations require that the appliance is earthed. The Manufacturer declines all liabilities for injury to persons or damage to property resulting from failure to observe these regulations.
- If the plug and socket are not of the same type, have the socket replaced by a qualified electrician.
- Do not use extension cables, multiple sockets or adapters.



⑧

# ELECTRICAL CONNECTION

## 1) For Great Britain only

**Warning - this appliance must be earthed**

### Fuse replacement

If the mains lead of this appliance is fitted with a BS 1363A 13amp fused plug, to change a fuse in this type of plug use an A.S.T.A. approved fuse to BS 1362 type and proceed as follows:

1. Remove the fuse cover (A) and fuse (B).
2. Fit replacement 13A fuse into fuse cover.
3. Refit both into plug.

### Important:

The fuse cover must be refitted when changing a fuse and if the fuse cover is lost the plug must not be used until a correct replacement is fitted.

Correct replacement are identified by the colour insert or the colour embossed in words on the base of the plug.

Replacement fuse covers are available from your local electrical store.

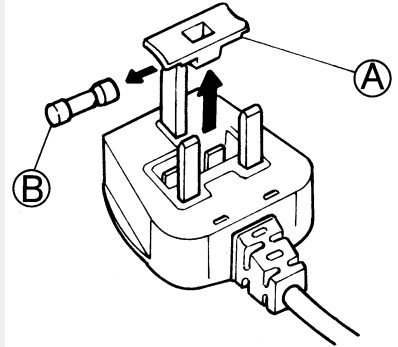

## 2) For the Republic of Ireland only

The information given in respect of Great Britain will frequently apply, but a third type of plug and socket is also used, the 2-pin, side earth type.

## 3) Socket outlet / plug (valid for both countries)

If the fitted plug is not suitable for your socket outlet, please contact Whirlpool Service for further instruction. Please do not attempt to change plug yourself. This procedure needs to be carried out by a qualified Whirlpool technician in compliance with the manufactures instructions and current standard safety regulations.