

AKP 288/NA

12NC: 857728801510

GTIN (EAN) code: 8003437816925

Whirlpool

SENSING THE DIFFERENCE



Whirlpool built in electric oven - AKP 288/NA

This Whirlpool built in Oven features: advanced electric technology allowing you to cook dishes saving energy. Halogen lamp allowing a more energy-efficient performance.



Multifunction 8

Multiple cooking methods. The Multifunction 8 feature offers flexible cooking options, to ensure perfect results, whatever the recipe.



Small cavity

This Whirlpool Oven features a compact-size cavity.



Energy class

Outstanding energy savings. Ovens with an A/ A+ energy rating offer an excellent level of energy efficiency, ensuring lower consumption and saving you money on your energy bills.



Energy class A

Energy efficient. With its A energy rating, this Whirlpool appliance will allow you to enjoy both ideal performance and excellent energy consumption.

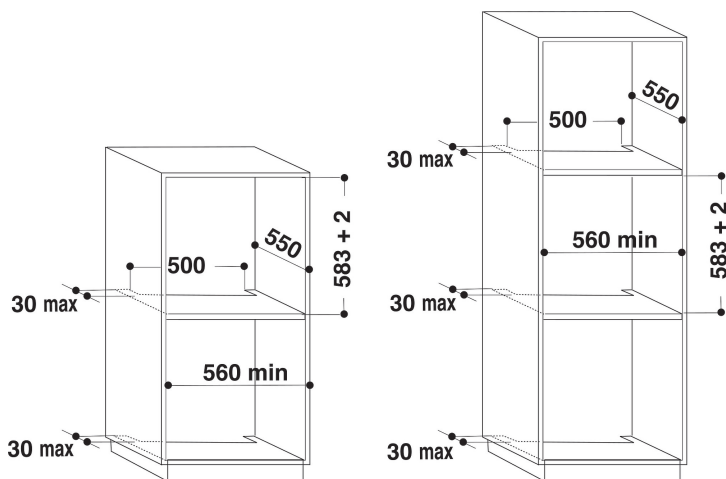

- Energy class A
- Cavity 56 L
- Defrost function
- Forced Air Fan Cooking
- Grill
- Easy Clean Enamel Interior
- Turbo grill function
- Pastry function
- Conventional Cooking
- Metal handle
- Door Glasses Number: 3
- Switch-off timer
- Grill 2500 W
- 2 Grids
- 1 Tray
- Mechanic programmer
- Float Glass and Black Bottom Front Trim

AKP 288/NA

12NC: 857728801510

GTIN (EAN) code: 8003437816925

Whirlpool

SENSING THE DIFFERENCE

MAIN FEATURES

Product group	Oven
Commercial code	AKP 288/NA
Main colour of product	New anthracite
Construction type	Built-in
Type of control	Mechanical
Type of control settings	-
Are any hobs controls integrated?	No
Which kind of hobs can be controlled?	-
Automatic programmes	No
Current (A)	16
Voltage (V)	220-240
Frequency (Hz)	50/60
Length of Electrical Supply Cord (cm)	90
Plug type	No
Depth with open door 90 degree (mm)	-
Height of the product	595
Width of the product	595
Depth of the product	564
Minimum niche height	0
Minimum niche width	0
Niche depth	0
Net weight (kg)	34
Usable volume (of cavity)	56
Integrated Cleaning system	No
Grids of the cavity	2
Trays	1

TECHNICAL FEATURES

Timer	-
Time control	Mechanical
Time-setting options	Start and Stop
Safety device	-
Interior light	Yes
Number of interior lights of the cavity	1
Position of interior lights of the cavity	Rear
Oven guides of the cavity	Wall-embedded
Probe of the cavity	No

PERFORMANCES

Energy input	Electric
Type of energy of the cavity	Electricity
Energy efficiency class - NEW (2010/30/EU)	A
Energy consumption per cycle conventional - NEW (2010/30/EU)	0.84
Energy consumption per cycle forced air convection - NEW (2010/30/EU)	0.75

ENERG Y UA
енергия · ενεργεια IE 1A

WHIRLPOOL AKP 288/NA

A+++
A++
A+
A
B
C
D

A

56 L

0.84 kWh/cycle*

0.75 kWh/cycle*

* ημερησια - cyklus - parhion - zyklos - nopolynayua - ciclo - tsükkel - ohjelma - ciklus - cikls - ciklu - cyclus - cykl - ciclu - program - cykel

65/2014