

# Whirlpool

## Refrigerator

### User Manual

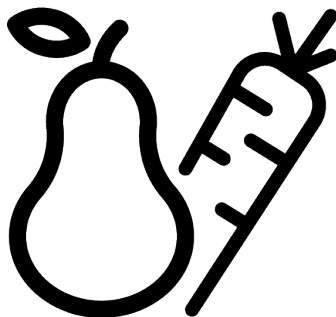

WHG2 6574W XK5UK

®/TM/© 2024 Whirlpool. Produced under license

15 7550 0104/ EN/ AD/ 10/02/2025 16:11  
7292341141



## Please read this manual first!

---

### Dear Customer

















Thank you for choosing this product.

Please register your products on [www.register10.eu](http://www.register10.eu)

We would like you to achieve the optimal efficiency from this high quality product which has been manufactured with state of the art technology. To do this, carefully read this manual and any other documentation provided before using the product.

Heed all information and warnings in the user manual. This way, you will protect yourself and your product against the dangers that may occur. Keep the user manual. Include this manual with the product if you hand it over to someone else.

**The following symbols are used in the user manual and on the product:**

	<b>Read the user manual.</b>									
<table border="1"><tr><td data-bbox="76 550 156 614"></td><td data-bbox="156 550 352 614"><b>ENERGY</b> </td><td data-bbox="352 550 456 614"></td></tr><tr><td data-bbox="76 614 291 646">SUPPLIER'S NAME</td><td data-bbox="291 614 456 646">MODEL IDENTIFIER → (*)</td><td></td></tr><tr><td data-bbox="76 646 156 707"></td><td data-bbox="291 646 456 707"></td><td></td></tr></table>		<b>ENERGY</b> 		SUPPLIER'S NAME	MODEL IDENTIFIER → (*)					<p>The model information as stored in the product data base can be reached by entering following website and searching for your model identifier (*) found on energy label.</p> <p><a href="https://eprel.ec.europa.eu/">https://eprel.ec.europa.eu/</a></p>
	<b>ENERGY</b> 									
SUPPLIER'S NAME	MODEL IDENTIFIER → (*)									
										



---

<b>1</b>	<b>Environmental Instructions .....</b>	<b>4</b>
1.1	Disposal Of Packaging Materials .....	4
<b>2</b>	<b>Your Refrigerator .....</b>	<b>4</b>
<b>3</b>	<b>Installation.....</b>	<b>5</b>
3.1	Electrical Connection .....	7
<b>4</b>	<b>Preparation.....</b>	<b>7</b>
4.1	What To Do For Energy Saving .....	7
4.2	First Use.....	8
4.3	Climate Class and Definitions .....	8
<b>5</b>	<b>Operating the Product.....</b>	<b>8</b>
<b>6</b>	<b>Control Panel of the Product .....</b>	<b>9</b>
<b>7</b>	<b>Use of Your Appliance.....</b>	<b>10</b>
7.1	Storing Food in the Freezer and Cooler Compartment.....	10
7.2	Replacing the Illumination Lamp..	13
7.3	Door Open Alert .....	13
<b>8</b>	<b>Product Features .....</b>	<b>13</b>
8.1	The ice storage area.....	13
8.2	Egg holder .....	15
8.3	Crisper .....	15
8.4	Dairy Products Cold Storage Area	15
8.5	Humidity Controlled Crisper .....	16
8.6	Water connection .....	16
<b>9</b>	<b>Maintenance and Cleaning .....</b>	<b>21</b>
<b>10</b>	<b>Troubleshooting.....</b>	<b>23</b>

---

# 1 Environmental Instructions

## 1.1 Disposal Of Packaging Materials

The packaging material is recyclable and is marked with the recycle symbol .

The various parts of the packaging must therefore be disposed of responsibly and in full compliance with local authority regulations governing waste disposal.

## 2 Your Refrigerator

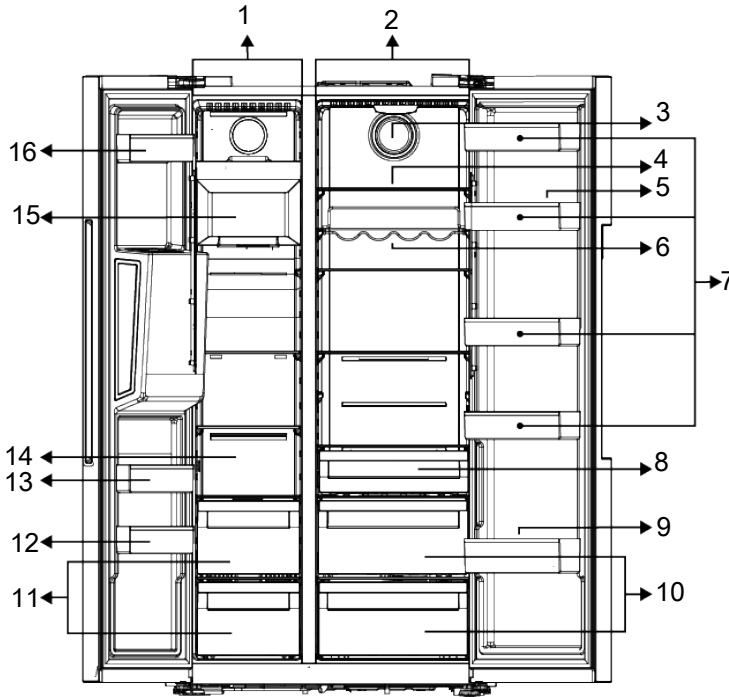

- |                                      |   |
|--------------------------------------|---|
| 1 Freezer compartment                | 2 Cooler compartment                                |
| 3 Fan                                | 4 *Cooler compartment glass shelves                 |
| 5 Egg holder                         | 6 *Bottle shelf                                     |
| 7 *Cooler compartment door shelves   | 8 *Dairy (cold storage) bin                         |
| 9 *Bottle shelf                      | 10 *Crispers  |
| 11 Frozen food storing compartments  | 12 *Freezer compartment door shelves                |
| 13 *Freezer compartment door shelves | 14 Frozen food storing compartments and glass shelf |
| 15 *Ice machine                      | 16 *Freezer compartment door shelves                |

**\*Optional:** Figures in this user manual are schematic and may not exactly match your product. If your product does not comprise the relevant parts, the information pertains to other models.

### 3 Installation

#### Right place for installation

Read the "Safety Instructions" first!

Contact the Authorized Service for the product's installation. To prepare the product for installation, see the information in the user manual and make sure the electric and water utilities are as required. If not, call an electrician and plumber to arrange the utilities as necessary.

- Damaged power cable must be replaced by Authorized Service.
- When placing two coolers in adjacent position, leave at least 4 cm distance between the two units.
- Keep the product out of direct sunlight and in a dry place.
- Your product requires adequate air circulation to function efficiently. If you place the product in an alcove, remember to leave at least 5 cm clearance between the product and the ceiling, rear wall and the side walls. Check if the rear wall clearance protection component is present at its location (if provided with the product). If the component is not available, or if it is lost or fallen, position the product so that at least 5 cm clearance shall be left between the rear surface of the product and the wall of the room. The clearance at the rear is important for efficient operation of the product.
- If the door span is too narrow for the product to pass, remove the door and turn the product sideways; if this does not work, contact the authorized service.
- Place the product on a flat surface to avoid vibration
- Place the product at least 30 cm away from the heater, stove and similar sources of heat and at least 5 cm away from electric ovens.

- Do not expose the product to direct sunlight or keep in damp environments.
- Before transport or use, never open the control board cover on the product. Risk of electric shock and fire!
- Our firm will not assume responsibility for any damages due to usage without earthing and without power connection in compliance with national regulations.
- The power cable plug must be easily accessible after installation.

#### Hot surface warning!

The side walls of your product are equipped with cooler pipes to enhance the cooling system. High pressure fluid may flow through these surfaces, and cause hot surfaces on the side walls. This is normal and it does not require servicing. Be careful when you contact these areas.

#### Attaching the plastic wedges

Use the plastic wedges provided with the product to maintain sufficient space for air circulation between the product and the wall.

- Remove the screws on the product and mount the screws provided with the wedges.

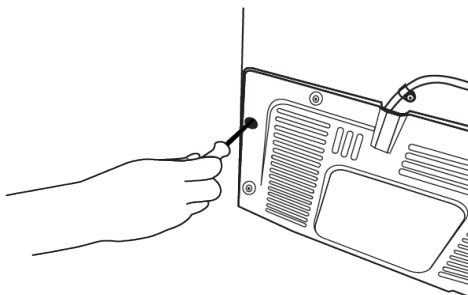

- Attach 2 plastic wedges on the ventilation cover as shown in the figure.

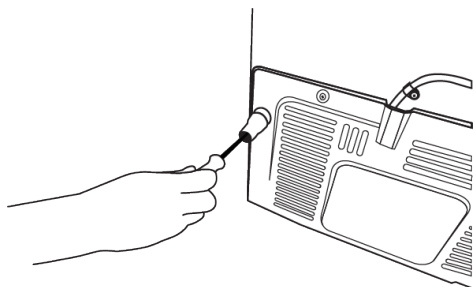

### Adjusting the Legs

If the product is not in balanced position, adjust the front adjustable stands by rotating right or left.

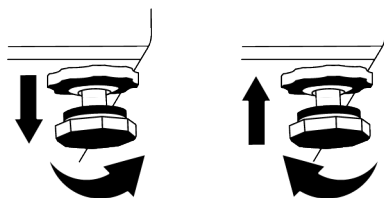

### For adjusting the doors vertically,

Loosen the fixing nut at the bottom. Screw adjusting nut (CW/CCW) according to the position of the door. Tighten the fixing nut bolt for the final position.

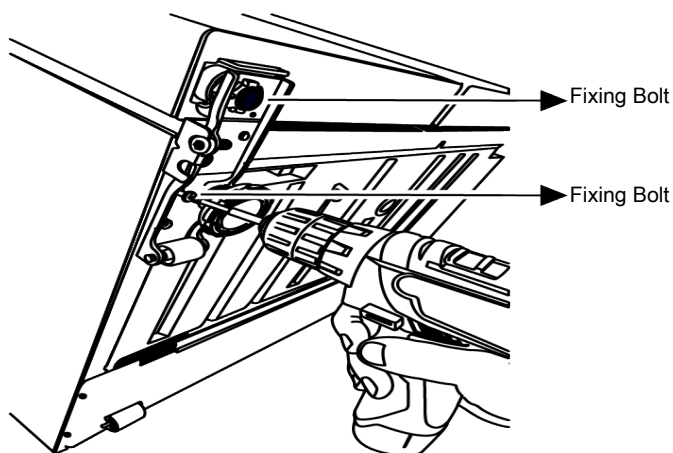

### For adjusting the doors horizontally,

Loosen the fixing screw at the bottom  
Loosen the fixing nut at the top. Screw the adjusting bolt (CW/CCW) on the side ac-

ording to the position of the door. Tighten the fixing bolt on the top for the final position  
Tighten the fixing screw at the bottom

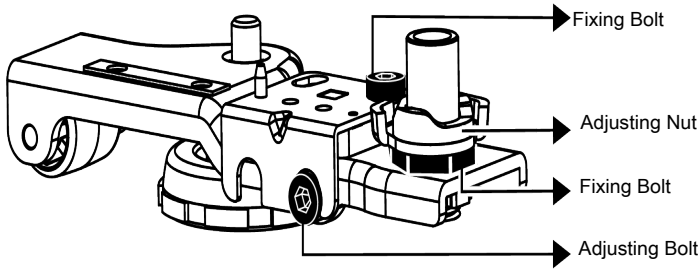

### 3.1 Electrical Connection



**WARNING:** Do not use extension cables or multi sockets in power connection.



**WARNING:** Damaged power cable must be replaced by Authorized Service.



**Hot surface warning!**  
The side walls of your product are equipped with cooler pipes to enhance the cooling system. High pressure fluid may flow through these surfaces, and cause hot surfaces on the side walls. This is normal and it does not require servicing. Be careful when you contact these areas.



Before transport or use, never open the control board cover on the product. Risk of electric shock and fire!

Our firm will not assume responsibility for any damages due to usage without earthing and without power connection in compliance with national regulations.

The power cable plug must be easily accessible after installation.

## 4 Preparation

Read the "Safety Instructions" first!

### 4.1 What To Do For Energy Saving

- This refrigerating appliance is not intended to be used as a built in appliance.
- When loading the food, leave enough space inside the refrigerator to allow sufficient air circulation for cooling.
- Since hot and humid air will not directly penetrate into your product when the doors are not opened, your product will optimize itself in conditions sufficient to protect your food. Under these circumstances, functions and components such as compressor, fan, heater, defrost, lighting, display and so on will operate according to the needs by consuming minimum energy.
- In case that multiple options are present, glass shelves must be placed so that the air outlets at the rear wall are not blocked and preferably, in a way that air outlets remain below the glass shelf. This combination may help improving air distribution and energy efficiency.

- Using the below drawer when storing is strongly recommended.
- For optimum performance, Quick Freezing can be used (if available), 24 hours prior to placing fresh foods in the freezer.
- In most cases, 24 hours is enough for the Quick Freezing function after fresh foods are placed in the freezer. After some time, Quick Freezing function will deactivate automatically.
- When freezing a small amount of food, Quick Freezing function can be deactivated after some time to ensure energy saving.
- Food shall be stored using the drawers in the cooler compartment in order to ensure energy saving and protect food in better conditions.
- A sound will be heard when the compressor is engaged. It is normal for the product to make noise even if the compressor is not running, as fluid and gas may be compressed in the cooling system.
- It is normal for the front edges of the product to be warm. These areas are designed to warm up in order to prevent condensation
- For some models, indicator panel turns off automatically 1 minute after the door closes. It will be reactivated when the door is opened or any button is pressed.

## 4.2 First Use

Before using your product make sure the necessary preparations are made in line with the instructions in "Safety Instructions" and "Installation" sections.

- Wait for at least 2 hours before operating the product, to ensure the complete efficiency of refrigeration.
- Keep the product running without placing any food inside for 6 hours and the product door should be kept as closed as possible.
- The temperature change caused by opening and closing of the door while using the product may normally lead to condensation on door/body shelves and glassware placed in the product.

## 5 Operating the Product

Read the "Safety Instructions" first!

- The product shall be used for storing food only.
- Turn off the water valve if you will be away from home (e.g. at vacation) and you will not be using the Icematic or the water dispenser for a long period of time. Otherwise, water leaks may occur.

## 4.3 Climate Class and Definitions

Please refer to the Climate Class on the rating plate of your device. One of the following information is applicable to your device according to the Climate Class.

- **SN:** Long Term Temperate Climate: This cooling device is designed for use at ambient temperatures between 10 °C and 32 °C.
- **N:** Temperate Climate: This cooling device is designed for use at ambient temperatures between 16°C and 32 °C.
- **ST:** Subtropical Climate: This cooling device is designed for use at ambient temperatures between 16°C and 38°C.
- **T:** Tropical Climate: This cooling device is designed for use at ambient temperatures between 16°C and 43°C.

## Unplugging the Product

- Remove the food to prevent odours,
- Wait for the ice to melt, clean the interior and let it dry, leave the doors open to avoid damaging the inner body plastics.

## 6 Control Panel of the Product

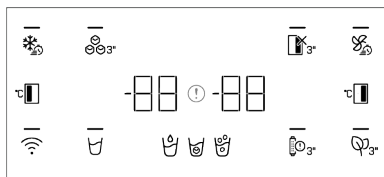

Read the "Safety Instructions" first!

Auditory and visual functions on the indicator panel will assist you in using the refrigerator.

\*Optional: Shown functions are optional, there may be differences of shape and location in functions found on your appliance's indicator panel.

### Quick Freezing Key

When the quick freezing key is pressed, the LED on the key is illuminated and the quick freezing function will be activated. Freezer compartment temperature is set to -27 Celsius. Press the key again to cancel the function. The quick freezing function will be cancelled automatically. To freeze a large amount of fresh food, press the quick freezing key before placing the food in the freezer compartment.

### Icematic On/Off Button

Pressing this key for 3 seconds activates the ice making process and the LED on the key lights up. Pressing the key for 3 seconds again cancels the ice making process and the ice cubes that have been created before can be used even though the function is cancelled.

### Error Status Indicator

This indicator shall be active when your refrigerator cannot perform adequate cooling or in case of any sensor error. "E" will be displayed on the freezer compartment temperature indicator and figures such as 1,2,3... will be displayed on the cooler compartment temperature indicator.

These figures provide information to the authorized service on the error that has occurred.

Exclamation mark may be displayed when you load warm food to the freezer compartment or keep the door open for a long period of time. This is not a fault, this warning will be removed when the food is cooled down or when any key is pressed.

### Cooler Compartment Off (Vacation)

#### Function Key

To activate the vacation function, press on the key for 3 seconds.

The vacation mode will be activated and the LED on the key will be illuminated. "-.-" shall be displayed on the Cooler Compartment temperature indicator and the cooler compartment does not actively perform cooling. You should not keep your food in the cooler compartment if you activate this function. The other compartments continue to cool according to temperatures set before. Press and hold the key for 3 seconds again to cancel this function.

### Quick Cooling Key

When you press the quick cooling key, the LED on the key is illuminated and the quick cooling function shall be activated. Cooler compartment temperature is set to 1 Celsius. Press the key again to cancel the function. The quick freezing function will be cancelled automatically when the cooling is done.

### Cooler Compartment Temperature Setting Key

Allows setting of temperature for cooler compartment. Pressing this key will enable the cooler compartment temperature to be set at 8,7,6,5,4,3,2 and 1 Celsius.

### Deodoriser Module Key

Press this key for 3 seconds to activate/deactivate the deodoriser feature. When the deodoriser feature is active, the LED on the respective key is illuminated. When the feature is active, the deodoriser module will be operated periodically.

### Filter Replacement Warning Key

The water inlet filter of the refrigerator should be changed in regular intervals. Your refrigerator will calculate this time automatically. When the filter lifespan has expired, the LED on the filter replacement warning key lights up. After changing the filter, press and hold the button for 3 seconds to turn off the filter replacement warning LED.

### Water, Ice Cube, Crashed Ice Selection

#### Key

This key allows you to switch between water, ice cube and crushed ice selections. When you activate the feature, light on the key shall remain lit.

### Wireless Key

This key is used to make a wireless connection with your product via HomeWhiz mobile app.

When you press the key for 3 seconds, the LED on the key flashes slowly (at intervals of 0.5 seconds). The home network is initialized on the product this way.

After achieving wireless connection with the product, the LED on the key illuminates permanently.

When the initial connection is established, you may activate/deactivate the connection with a short press on this key. The LED on the key shall flash quickly (at intervals of

0.2 seconds) till your appliance is connected. When the connection is active, LED will remain lit.

If the connection cannot be established for a long period, check your connection settings and refer to the “Troubleshooting” section provided in the user manual.

HomeWhiz application will be used for wireless connection. The installation steps are described on the application during installation. You may access the application by reading the QR code available on the HomeWhiz label on the product. Application is offered through App Store for IOS devices, and through Play Store for Android devices.

Visit <https://www.homewhiz.com/> address for detailed information.

### Freezer Compartment Temperature Setting Key

Temperature setting is made for freezer compartment. Pressing this key will enable the freezer compartment temperature to be set at -16,-17,-18,-19,-20,-21,-22 Celsius.

## WARNING

 **The temperature can be set between 1-8°C for the chiller compartment and between -24 and -15°C for the freezer compartment. Adjustable temperature values may vary provided that they are within these ranges according to product specifications.**

## 7 Use of Your Appliance

### 7.1 Storing Food in the Freezer and Cooler Compartment

#### Storing food in the freezer compartment

- You can activate Quick Freezing function 4-6 hours before freezing function and perform a faster cooling.
- Bring hot meals to the room temperature before placing them in the freezer compartment.

- Foods to be frozen must be divided into portions according to a size to be consumed, and frozen in separate packages.
- It is recommended to pack the foods before placing them in the freezer.
- In order to prevent expiration of storage time, write the freezing date, time and name of the product on the package according to the storage times of different foods.

- Consume the foods you have defrosted quickly. Defrosted foods cannot be frozen again unless they are cooked. It is not safe to consume the refrozen fresh foods without cooking after they are defrosted.
- As you freeze fresh foods, do not bring them in contact with already frozen foods. Otherwise, frozen foods will be defrosted.

### **Storing the foods, which are sold frozen**

- Always follow the instructions of the producer in relation to the time during which you are required to store your foods. Do not exceed the time specified in these instructions!
- In order to protect the quality of the food, keep the time interval between purchasing transaction and storing as short as possible.
- Buy frozen food which are stored at  $-18^{\circ}\text{C}$  or lower temperatures.
- Avoid buying foods whose packages are covered with ice etc. This means that the product could be partially defrosted and refrozen. Temperature impacts the quality of the food.
- Do not exceed the storing time recommended by the food producer. Remove only the food as much as you need from the freezer.
- Except the cases where extreme circumstances are available in the environment, if your product (on the recommended set values table) is set to the specified set values, the food keep their freshness for a longer time both in the fresh product compartment and freezer compartment.
- If fresh food compartment is set to a lower temperature, fresh fruits and vegetables may be partially frozen.

### **Quick freezing**

1. Activate the quick freezing function 24 hours before placing your fresh foods.
2. After 24 hours after pressing the button, place your food that you want to freeze in the third or fourth shelves with higher freezing capacity.

3. Once the quick freezing function is activated, it is automatically cancelled after a period of time.

### **Freezer details**

As per the IEC 62552 standards, the freezer must have the capacity to freeze 4,5 kg of food items at  $-18^{\circ}\text{C}$  or lower temperatures at  $25^{\circ}\text{C}$  room temperature in 24 hours for each 100 litres of freezer compartment volume.

Food products can only be preserved for extended periods at or below temperature of  $-18^{\circ}\text{C}$ .

You can keep the foods fresh for months (in freezer at or below temperatures of  $-18^{\circ}\text{C}$ ).

The food products to be frozen must not contact the already-frozen food inside to avoid partial defrosting.

Boil the vegetables and filter the water to extend the frozen storage time. Place the food in air-tight packages after filtering and place in the freezer. Bananas, tomatoes, lettuce, celery, boiled eggs, potatoes and similar food items should not be frozen. In case these foods are frozen, only nutritional values and eating qualities will be negatively affected. A rotting that would threaten human health is not in question.

### **Placing the food**

**Freezer compartment shelves:** Different frozen foods like meat, fish, ice cream, vegetables etc.

**Cooler compartment shelves:** Food items inside pots, capped plate and capped cases, eggs (in closed case)

**Cooler compartment door shelves:** Small and packaged food or beverages

**Crisper:** Vegetables and fruits

**Fresh food compartment:** Delicatessen (breakfast food, meat products to be consumed in short time)

### **Storing food in the cooler compartment**

- Compartment temperatures rise prominently if compartment door is opened and closed frequently and kept open for a long time, this can reduce the life span of the food and cause the food to spoil.

- In order not to cause odour and taste changes, the food should be stored in the closed containers.
- Do not store too much food in your refrigerator. To achieve a better and homogeneous cooling, place the food separately in a way that cold air can wander through them.
- Provide air flow by leaving a space between the food and internal wall. If you lean the food against the rear wall, the food may freeze.
- Bring cooked hot meals to the room temperature before placing them in the refrigerator. Then, you can place the tepid meal in the lower shelves of your refrigerator. Do not place the tepid meals close to the foods which may easily spoil.
- Defrost your frozen food in the fresh food compartment. Thereby, you can cool fresh food compartment by using frozen food and save energy.
- Storing unripe tropical fruits (mango, melon varieties, papaya, banana, pineapple) in the refrigerator may speed up the ripening process. This is not recommended because it will cause shorter storage time.
- You should store onions, garlands, ginger and other root vegetables in dark and cold room conditions, not in the refrigerator.
- If you notice that a food has spoiled in the refrigerator, throw away that food and clean the accessories which have come into contact with it.
- In order to cool the meals like soups and stews, which are cooked in the large pots, quickly, you can put them in the refrigerator by separating them into their own shallow containers.
- Do not place unpackaged food close to eggs.
- Keep the fruits and vegetables separately and store each variety together (for example; apples with apples, carrots with carrots).
- Take green vegetables out of the plastic bag and place them in the refrigerator after wrapping them in a paper towel or drying cloth. If you wash this type of food before placing them in the refrigerator, remember to dry them.
- You can both create a damp environment and provide an air flow by keeping fruits and vegetables, which are prone to drying, in the perforated or unsealed plastic bags.
- Except the cases where extreme circumstances are available in the environment, if your product (on the recommended set values table) is set to the specified set values, the food keep their freshness for a longer time both in the fresh product compartment and freezer compartment.

**Store different food in different places according to their properties.**

Food	Location
Egg	Door Shelf
Dairy products (butter, cheese)	If available, zero degree (for breakfast food) compartment
Fruits, vegetables and greenery	Fruit-vegetable compartment, crisper or EverFresh+ compartment (if available)
Fresh meat, poultry, fish, sausage etc. Cooked foods	If available, zero degree (for breakfast food) compartment
Ready to serve foods, packaged products, canned foods and pickles	Top shelves or door shelf
Beverages, bottles, spices and snacks	Door Shelf

## Recommended set values table

Freezer Compartment Setting	Fridge Compartment Setting	Remarks
-22°C	4°C	This is the default, recommended setting. This setting is recommended if ambient temperature is below 30°C.
-22°C or colder	4°C	These settings are recommended for ambient temperatures exceeding 30°C.
Quick Freeze	4°C	Use when you want to freeze your food in a short time. When the process ends, the product's settings will return to previous position.
-18°C or colder	2°C	Use these settings if you believe the cooler compartment is not cold enough due to ambient temperature or frequently opening the door.

### 7.2 Replacing the Illumination Lamp

Call the Authorized Service when the Bulb/LED used for lighting in your refrigerator will be replaced.

Lamp(s) used in this appliance cannot be used for house lighting. Intended use of this lamp is to help the user place food into the refrigerator / freezer safely and comfortably.

### 7.3 Door Open Alert

The door open alert system of your refrigerator may differ depending on the model.

#### Version 1;

If the door of the product remains open for a certain time (between 60 s and 120 s), an audio warning signal sounds; depending on the product model, a visual warning signal

(light flash) can also be displayed. If you close the door of the device or press a button on the screen of the device, if any, the warning sound will stop.

#### Version 2;

If the door of the device remains open for a certain period of time (between 60 s and 120 s), the door open alert is sounded. The door open alert is sounded gradually. First, an audible warning starts to sound. After 4 minutes, if the door is still not closed, a visual warning (lighting flash) is activated. The door open alert will be delayed for a certain period of time (between 60 s and 120 s) when any key on the product screen, if any, is pressed. Then the process will start again. When the device door is closed, the door open alert will be cancelled.

## 8 Product Features

### 8.1 The ice storage area

#### Ice/Water Taking

Select the related option by using the display in order to take water (🍹) / ice cube

(🧊) / crushed ice (🧊). Push forward the trigger on the water dispenser in order to take water/ice. When you switch between

ice cube (🧊) / crushed ice (🧊) options, ice type remaining from the previous selection can be given in the first few takings.

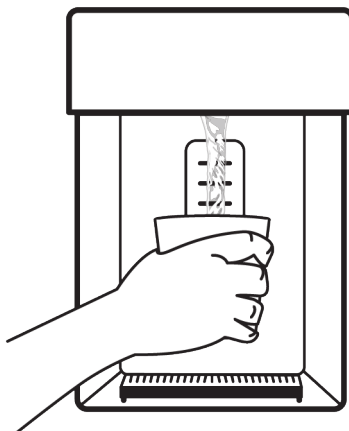

- In order to take ice from ice / water dispenser for the first time, you have to wait approximately for 12 hours. In the event that there is not sufficient ice in the ice container, you cannot take ice from the dispenser.
- Do not consume the ice cubes (3-4 litres) after first running.
- If a power failure or temporary malfunction arises while the product is running, ices may melt a little and refreeze. In this case, ices may stick to each other. In the event that the power failure or the malfunction goes on, ices may melt and cause a water leakage. When such a problem exists, clean the ice container by pouring the ices left in the ice container.
- The water system of the product should only be connected to cold water line. It should not be connected to the hot water line.
- Water may not be taken during the first operation of the product. This is because there is air in the system. You have to discharge the air in the system. For this purpose, press on the trigger of the dispenser for 1-2 minutes until the water comes from the water dispenser. At the beginning, the water flow may be irregular. Water flow will return to normal after the air in the system is discharged.
- A blurry water may come out when the filter is used for the first time. The first 10 glasses of water should not be consumed.
- When the product is set up for the first time, approximately 12 hours should be passed for the water to cool.
- The water system of the product has been designed in a way that it can only work with clean water. Do not use any beverage except water.
- If you will not use the product for a long time for the reasons of vacation etc., we recommend you to cancel the water connection. When the water dispenser is not used for a long time, the first 1-2 glasses of water may come out hot.

### Drip tray

The water dripping from the water dispenser accumulates on the drip tray, there is not a water outlet. You can take out the drip tray by pulling it toward yourself or pressing on its edge. You can clean the water in the drip tray in this way.

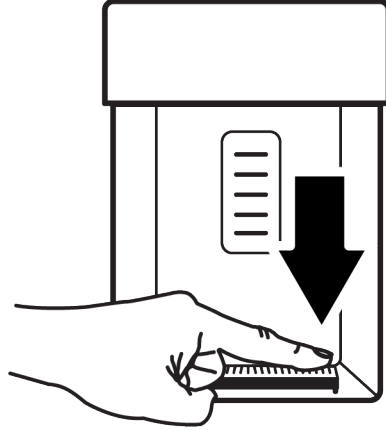

### Ice Machine

Ice machine is on the upper section of the freezer body.

By grabbing the handle under the front part, pull the ice storage bin towards yourself to remove.

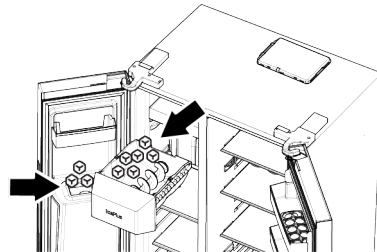

### To remove the ice storage bin

Grab the handle on the bottom of the bin and pull it towards yourself.

### To reinstall the ice storage bin

Put the bin to its slot and push it back holding parallel to the ground. Please make sure that no space will be left between the bin and the ice maker compartment.

### In case you cannot get all the ice cubes produced

Ice cubes remaining in the storage bin for a long time may stick together and form large ice blocks. In this case, remove the ice storage bin as described in the manual, separate ice cubes, remove the ones that cannot be separated from the bin and put the remaining cubes back into the bin. If the problem persists, please check the ice channel, and clear if it is blocked.

### **When using the ice machine for the first time or after a long period**

Ice cubes may get smaller due to the residual air in the water system. The air will be automatically discharged after being used for some time.

- Do not use the ice cubes produced on the first day so that you can refresh all remaining water in the system.
- Do not insert your hand or any other object into the ice channel and ice crushing blades while the refrigerator is operating.
- Do not allow kids to hang onto the ice machine, ice storage bin or water/ice dispenser.
- Grasp the ice storage bin firmly with both hands so as not to drop it.
- When you close the door of your appliance fast, the water in the ice maker may splash into the ice storage bin.
- Do not disassemble the ice storage bin unless necessary.
- In case of a jam (appliance does not drop ice) while getting crushed ice, try getting ice cube.
- Then you can retry getting crushed ice.
- When getting crushed ice, the appliance may produce ice cubes first. It is possible for the appliance to produce ice cubes when getting crushed ice.
- The freezer door of the ice machine may be covered by a light frost and a film layer.
- This is normal and we recommend you to immediately clean it.
- After some time, water may fill in the grid which is at the bottom of the water dispenser.
- We recommend you to remove the water in the grid regularly.

- It is normal to hear a sound when ice cubes are falling down from the ice storage bin. This does not mean any malfunction.
- The blade mechanism of the ice bin is sharp and may injure your hand.
- If ice cubes aren't released from the ice dispenser, it means that the ice cubes may be stuck together. You need to clean the bin to continue to get ice cubes.
- When the trigger is pressed to get ice (Indicator etc.), ice type cannot be changed. You should release the trigger (Indicator etc.), change the ice type and take ice again. For this purpose, you can take ice again after changing the ice type on the indicator.

## **8.2 Egg holder**

You can place the egg holder on the door or body shelf you wish.

If the egg holder is to be placed on the body shelf, we recommend you to choose colder lower shelves.

- Never place the egg holder on the freezer compartment.

## **8.3 Crisper**

The refrigerator's crisper is designed to keep vegetables fresh by preserving their humidity. For this purpose, the overall cold air circulation is intensified in the crisper. Keep fruits and vegetables in this compartment. Keep the green-leaved vegetables and fruits separately to prolong their life.

## **8.4 Dairy Products Cold Storage Area**

### **Cold Storage Drawer**

The Cold Storage Drawer can reach lower temperatures in the cooler compartment. Use this drawer for delicatessen products (salami, sausage, etc.) and dairy products that require colder storage conditions, or for meat, chicken or fish to be consumed quickly. It is not suitable to store fruits and vegetables in this drawer.

## 8.5 Humidity Controlled Crisper

With the humidity controlled crisper feature, the humidity of vegetables and fruits is kept under control and the food is kept fresh for a longer period of time.

We recommend that you place leafy vegetables such as lettuce, spinach and similar vegetables that are sensitive to moisture loss in the crisper, not upright on their roots, but as horizontally as possible.

When placing the vegetables, place heavy and hard vegetables at the bottom and light and soft ones on the top, taking into account the specific weights of vegetables.

Never leave vegetables in plastic bags in the crisper. Leaving them in plastic bags causes vegetables to rot in a short time. In situations where contact with other vegetables is not preferred, use packaging materials such as paper that has a certain level of porosity in terms of hygiene.

Do not put fruits that have a high ethylene gas production such as pear, apricot, peach and particularly apple in the same crisper with other vegetables and fruits. The ethylene gas coming out of these fruits might cause other vegetables and fruits to mature faster and rot in a shorter period of time.

## 8.6 Water connection

(This feature is optional)



### WARNING

The product and the water pump, if any, must be unplugged during connection.

The mains, filter and carboy connections of your product must be made by an authorized service center.

Depending on the model, you can connect your product to a carboy or directly to the water network. To make this connection, you must first connect the water hose to the product.

Depending on the model of your product, check whether the following parts are included with the product:

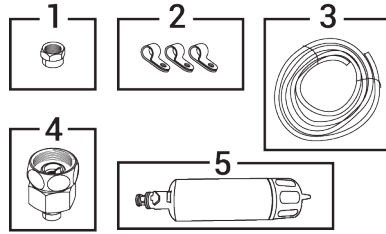

1. Union (1 piece) : Used for attaching the water hose to the back of the product.
2. Hose clip ( 3 pieces ) : Used for fixing the water hose to the wall.
3. Water hose (1 piece, 5 meters diameter 1/4 inch): Used for making water connections.
4. Faucet adapter ( 1 piece ) : Used for cold water mains line connection with porous filter.
5. Water filter (1 piece \*Optional): It is used to connect the mains water to the product. If there is a carboy connection; there is no need to use a water filter.

### Connecting the water hose to the product

Follow the instructions below to connect the water hose to the product.

1. Remove the fitting from the hose end adapter attached to the back of the product, thread the fitting onto the water hose.

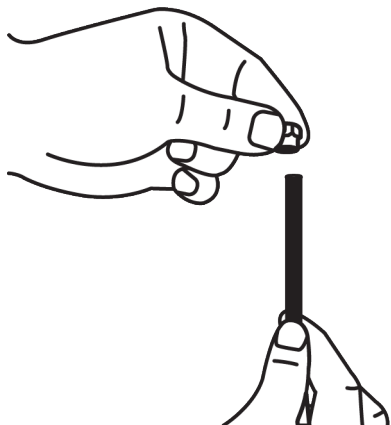
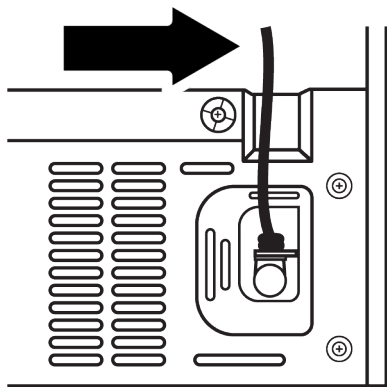

2. Attach the water hose to the hose-end adapter by pressing down firmly.

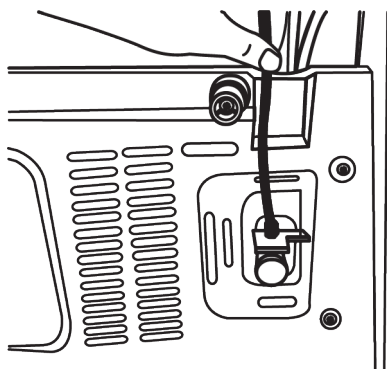

3. Secure the union to the hose-end adapter by hand tightening. You can tighten the union using a pipe wrench or pliers.

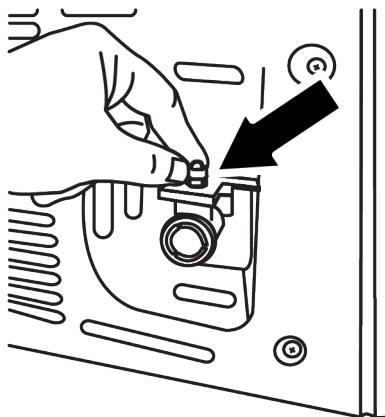

### Connecting to mains water

(This feature is optional)

If you are going to use the product by connecting it to the cold water line, you need to install a standard 1/2" valve fitting on the cold water network in your home. If this fitting is not available and you are not sure, consult a qualified plumber.

1. Disconnect the union from the faucet adapter.

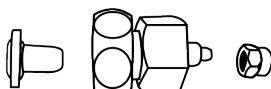

2. Connect the faucet adapter to the mains line valve.

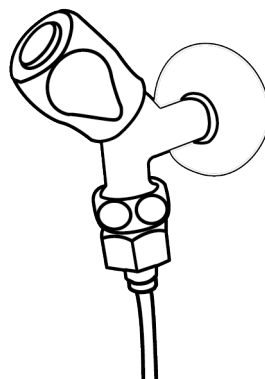

3. Thread the union onto the water hose.

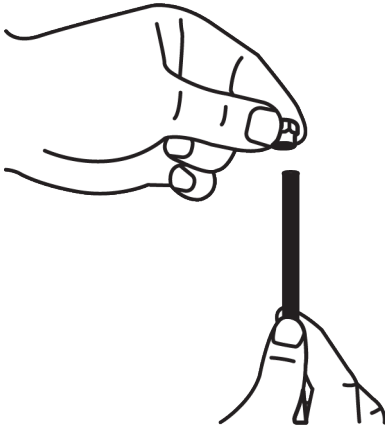

4. Thread the union onto the faucet adapter and tighten by hand/tool.

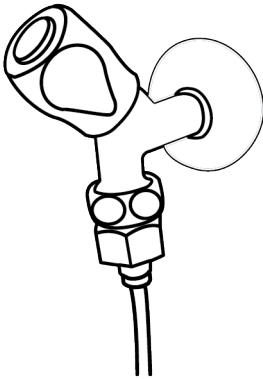

5. Secure the water hose in suitable places with the clips provided to prevent damage, slipping or accidental dislodging.

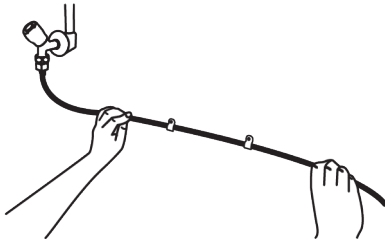

### WARNING

After opening the faucet, make sure that there is no water leakage at both joints of the water hose. In case of leakage, close the valve immediately and tighten all joints with a pipe wrench or pliers.

### For products to be used in carboys;

(This feature is optional)

In order to connect carboy water to the product, the water pump recommended by the authorized service is required.

In order to connect carboy water to the product, the water pump recommended by the authorized service is required.

1. After connecting one end of the water hose from the pump to the product, follow the instructions below.

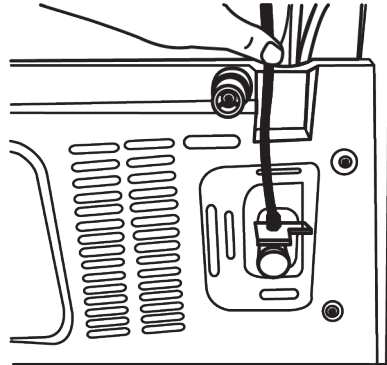

2. Make the connection by pushing the other end of the water hose into the water hose inlet of the pump.

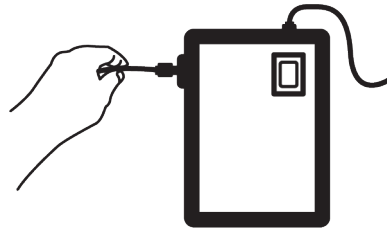

3. Secure the pump hose by placing it into the carboy.

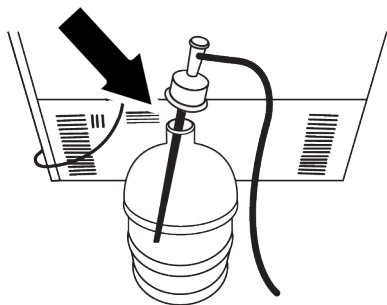

4. After completing the connection, plug the pump into the socket and start the pump.

**i** After starting the pump, wait 2-3 minutes for it to reach the desired efficiency.

**i** Refer to the instruction manual of the pump while making the water connection.

**i** If carboy will be used, there is no need to use a water filter.

### Water filter

(This feature is optional)

Depending on the model, your product may have an external or internal filter. To install the water filter, follow the instructions below.

### Mounting the external filter on the wall

(This feature is optional)

**WARNING**  
 Do not install the filter on the product.

Depending on the model of your product, check whether the following parts are included with the product:

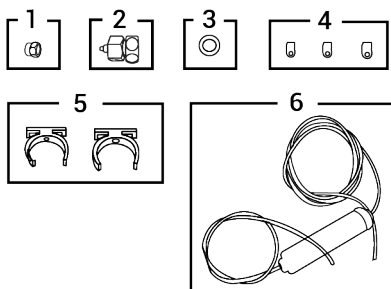

1. Union (1 piece) : Used for attaching the water hose to the back of the product.
2. Faucet adapter ( 1 piece ) : Used for cold water mains line connection.
3. Porous filter ( 1 piece )
4. Hose clip ( 3 pieces ) : Used for fixing the water hose to the wall.
5. Filter connection apparatus ( 2 pieces ) : Used for mounting the filter on the wall.
6. Water filter (1 piece): It is used to connect the mains water to the product. If there is a carboy connection; there is no need to use a water filter.
7. Connect the faucet adapter to the mains line valve.
8. Determine the place where the external filter will be fixed. Mount the filter connection apparatus ( 5 ) on the wall.
9. Attach the filter perpendicularly to the filter bracket as indicated on the label. ( 6 ).

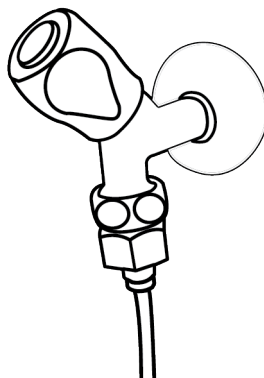

10. Connect the water hose coming out of the top of the filter to the water connection adapter of the product.

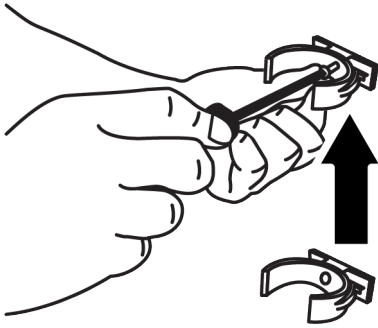

11. After the connection is completed, the image should be as shown below.

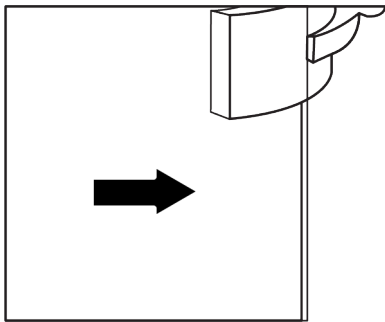
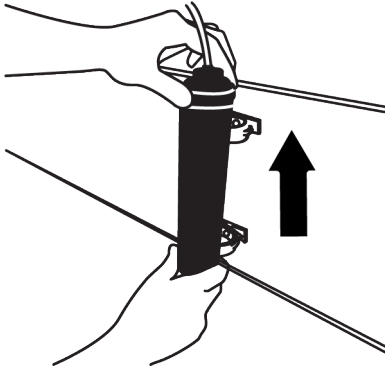

Since the internal filter that comes in the product does not come installed, the necessary procedures for its preparation are as follows:

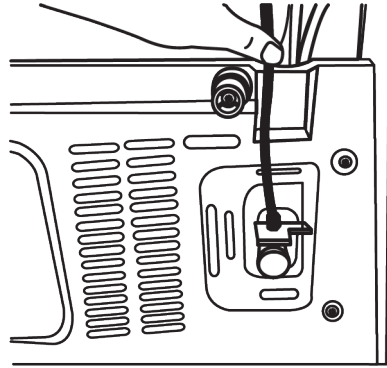

**Water line**

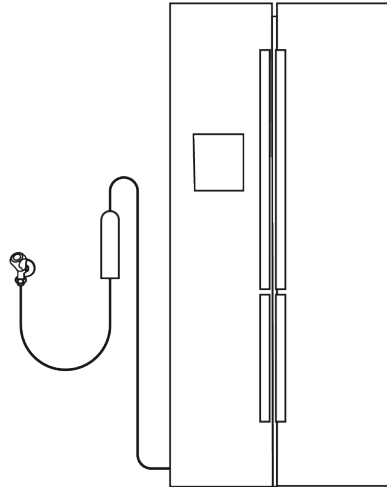

**Carboy line:**

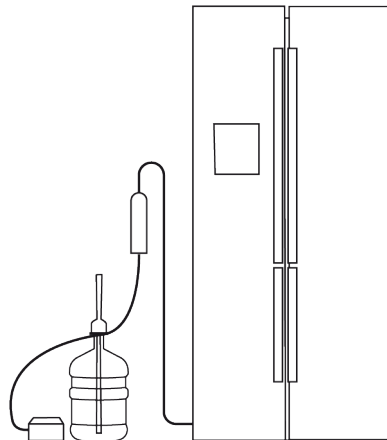



Do not use the first 10 glasses of water after connecting the filter.

1. For filter installation, the **"Ice Off" indicator** must be active. Switching between ON and OFF indicators on the display is done by pressing the **"Ice"** button.

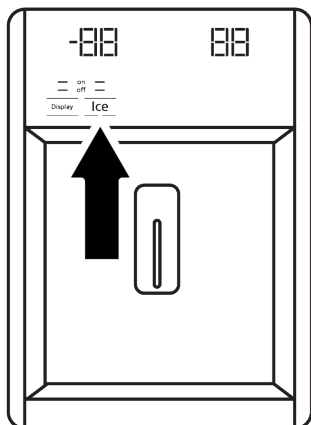

2. Remove the crisper compartment to access the water filter.
3. Remove the water filter by-pass cover by pulling it towards you.



It is normal for a few drops of water to come out after the cover is removed.

4. Insert the water filter cover into the mechanism and push it forward to lock it in place.

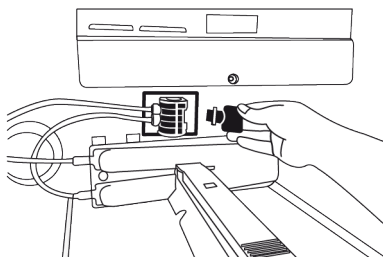

5. Exit the **"Ice Off"** mode by pressing the **"Ice"** button on the display again.

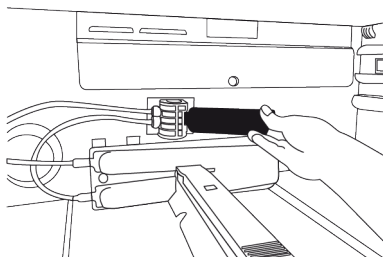

The water filter removes some foreign particles from the water. It does not purify the water from microorganisms.

## 9 Maintenance and Cleaning

Read the "Safety Instructions" first!

Before cleaning your product, unplug it or de-energize the fuse to which it is connected.

Do not place your hands, feet or metal objects under the refrigerator or between the refrigerator and the floor for whatsoever reason. Jamming may occur or any sharp edge may cause personal injuries.

- Do not use sharp or abrasive tools to clean the product. Do not use materials such as household cleaning agents, soap, detergents, gas, gasoline, thinner, alcohol, wax, etc.
- The dust shall be removed from the ventilation grill on the rear of the product at least once a year (without opening the cover). Clean the product with a dry cloth.

### For products with Water Dispenser / Ice Maker

- If the water in the water tank has waited for 2-3 weeks, it shall be replaced.

- The water tank and the components of the water dispenser shall not be washed in dishwashers.
- Melt a teaspoonful of carbonate in half a litre of water. Moisten a piece of cloth in the water and wring out. Wipe the device with this cloth and dry off thoroughly.
- Take care to keep water away from the lamp's cover, LED lighting glass, vent holes or other electrical parts. Risk of electric shock and short circuit!
- Do not open live sections (control board cover, compressor rear cover if any, etc.) without the presence of an authorized person and do not perform any cleaning, maintenance or repair here. If your product has no cover in the compressor section, do not touch this area with your hands or with any object. Risk of electric shock and injury!
- Clean the door with a damp cloth. Remove door and body racks, as well as all contents within the refrigerator. Remove the door racks by lifting them upwards. Clean and dry the racks, then attach back in place by sliding from above.
- Do not use chlorinated water or cleaning products on the exterior surface and chrome coated parts of the product. Chlorine will cause rust on such metallic surfaces.
- Do not place your hands, feet or metal objects under the refrigerator. Jamming may occur or any sharp edge may cause personal injuries..
- Do not use sharp and abrasive tools, soap, house cleaning materials, detergents, gas, gasoline, varnish and similar substances to prevent deformation of and removal of prints on the plastic part. Use warm water and a soft cloth for cleaning, and then dry it.
- Water droplets and icing up to a thickness of a finger may occur on the rear wall of the freezer compartment. Do not clean, and never apply oils or similar materials.
- Use a mildly dampened micro-fibre cloth to clean the external surface of the product. Sponges and other types of cleaning clothes may cause scratches.
- To clean all removable components during the cleaning of the interior surface of the product, wash these components with a mild solution consisting of soap, water and carbonate. Wash and dry thoroughly. Prevent contact of water with illumination components and the control panel.
- Take care to keep water away from the lamp's cover and other electrical parts.
- Clean the door with a damp cloth. Remove all contents to remove the door and body racks. Remove the door racks by lifting them upwards. Clean and dry the shelves, then attach back in place by sliding from above.
- Do not use chlorinated water or cleaning products on the exterior surface and chrome coated parts of the product. Chlorine will cause rust on such metallic surfaces.
- Do not use sharp and abrasive tools, soap, house cleaning materials, detergents, gas, gasoline, varnish and similar substances to prevent deformation of and removal of prints on the plastic part. Use warm water and a soft cloth for cleaning, and then dry it.
- On the products without a No-Frost feature, water droplets and icing up to a thickness of a finger may occur on the rear wall of the cooler compartment. Do not clean, and never apply oils or similar materials.
- Use only a mildly dampened micro-fibre cloth to clean the external surface of the product. Sponges and other types of cleaning clothes may cause scratches.

**On the products without a No-Frost feature;**

- To clean all removable components during the cleaning of the interior surface of the product, wash these components with a mild solution consisting of soap, water and carbonate. Wash and dry thoroughly. Prevent contact of water with illumination components and the control panel.
- Do not use vinegar, rubbing alcohol or other alcohol based cleaning agents on any interior surface.

### **Stainless Steel External Surfaces**

Use a non-abrasive stainless steel cleaning agent and apply it with a soft lint-free cloth. To polish, gently wipe the surface with a micro-fibre cloth dampened with water and use dry polishing chamois. Always follow the veins of the stainless steel.

## **10 Troubleshooting**

Read the "Safety Instructions" first!

Check this list before contacting the service. Doing so will save you time and money. This list includes frequent complaints that are not related to faulty workmanship or materials. Certain features mentioned herein may not apply to your product.

If the problem persists after following the instructions in this section, contact your vendor or an Authorized Service. Do not try to repair the product.

### **The refrigerator is not working.**

- The power plug is not fully settled. >>> Plug it in to settle completely into the socket.
- The fuse connected to the socket powering the product or the main fuse is blown. >>> Check the fuse.

### **Condensation on the side wall of the cooler compartment (MULTI ZONE, COOL CONTROL and FLEXI ZONE).**

- The door is opened too frequently. >>> Take care not to open the product's door too frequently.
- The environment is too humid. >>> Do not install the product in humid environments.

### **Preventing Odours**

The product is manufactured free of any odorous materials. However, inappropriately storing food and improper cleaning of internal surfaces may lead to odours.

- To avoid this, clean the inside with carbonated water every 15 days.
- Keep the foods in sealed holders, as micro-organisms arising from foods kept in unsealed containers will cause bad odour.
- Do not keep expired and spoilt foods in the refrigerator.

### **Protecting Plastic Surfaces**

Oil spilled on plastic surfaces may damage the surface and must be cleaned immediately with warm water.

- Foods containing liquids are kept in unsealed holders. >>> Keep the foods containing liquids in sealed holders.
- The product's door is left open. >>> Do not keep the product's door open for long periods.
- The thermostat is set to a very cool temperature. >>> Set the thermostat to an appropriate temperature.

### **Compressor is not working.**

- In case of sudden power failure or pulling the power plug off and putting back on, the gas pressure in the product's cooling system is not balanced, which triggers the compressor thermic safeguard. The product will restart after approximately 6 minutes. If the product does not restart after this period, contact the service.
- Defrosting is active. >>> This is normal for a fully-automatic defrosting product. The defrosting is carried out periodically.
- The product is not plugged in. >>> Make sure the power cord is plugged in.
- The temperature setting is incorrect. >>> Select the appropriate temperature setting.
- The power is out. >>> The product will continue to operate normally once the power is restored.

**The refrigerator's operating noise is increasing while in use.**

- The product's operating performance may vary depending on the ambient temperature variations. This is normal and not a malfunction.

**The refrigerator runs too often or for too long.**

- The new product may be larger than the previous one. Larger products will run for longer periods.
- The room temperature may be high. >>> The product will normally run for long periods in higher room temperature.
- The product may have been recently plugged in or a new food item is placed inside. >>> The product will take longer to reach the set temperature when recently plugged in or a new food item is placed inside. This is normal.
- Large quantities of hot food may have been recently placed into the product. >>> Do not place hot food into the product.
- The doors were opened frequently or kept open for long periods. >>> The warm air moving inside will cause the product to run longer. Do not open the doors too frequently.
- The freezer or cooler door may be ajar. >>> Check that the doors are fully closed.
- The product may be set to a temperature that is too low. >>> Set the temperature to a higher degree and wait for the product to reach the adjusted temperature.
- The cooler or freezer door washer may be dirty, worn out, broken or not properly settled. >>> Clean or replace the gasket. Damaged / torn door washer will cause the product to run for longer periods to preserve the current temperature.

**The freezer temperature is very low, but the cooler temperature is adequate.**

- The freezer compartment temperature is set to a very low degree. >>> Set the freezer compartment temperature to a higher degree and check again.

**The cooler temperature is very low, but the freezer temperature is adequate.**

- The cooler compartment temperature is set to a very low degree. >>> Set the cooler compartment temperature to a higher degree and check again.

**The food items kept in cooler compartment drawers are frozen.**

- The cooler compartment temperature is set to a very low degree. >>> Set the cooler compartment temperature to a higher degree and check again.

**The temperature in the cooler or the freezer is too high.**

- The cooler compartment temperature is set to a very high degree. >>> Temperature setting of the cooler compartment has an effect on the temperature in the freezer compartment. Wait until the temperature of relevant parts reach the sufficient level by changing the temperature of cooler or freezer compartments.
- The doors were opened frequently or kept open for long periods. >>> Do not open the doors too frequently.
- The door may be ajar. >>> Fully close the door.
- The product may have been recently plugged in or a new food item is placed inside. >>> This is normal. The product will take longer to reach the set temperature when recently plugged in or a new food item is placed inside.
- Large quantities of hot food may have been recently placed into the product. >>> Do not place hot food into the product.

**Shaking or noise.**

- The surface is not flat or durable >>> If the product is shaking when moved slowly, adjust the stands to balance the product. Also make sure the ground is sufficiently durable to bear the product.
- Any items placed on the product may cause noise. >>> Remove any items placed on the product.
- The product is making noise of liquid flowing, spraying etc.
- The product's operating principles involve liquid and gas flows. >>> This is normal and not a malfunction.

**There is sound of wind blowing coming from the product.**

- The product uses a fan for the cooling process. This is normal and not a malfunction.

**There is condensation on the product's internal walls.**

- Hot or humid weather will increase icing and condensation. This is normal and not a malfunction.
- The doors were opened frequently or kept open for long periods. >>> Do not open the doors too frequently; if open, close the door.
- The door may be ajar. >>> Fully close the door.

**There is condensation on the product's exterior or between the doors.**

- The ambient weather may be humid, this is quite normal in humid weather. >>> The condensation will dissipate when the humidity is reduced.

**The interior smells bad.**

- The product is not cleaned regularly. >>> Clean the interior regularly using sponge, warm water and carbonated water.

- Certain holders and packaging materials may cause odour. >>> Use holders and packaging materials without free of odour.
- The foods were placed in unsealed holders. >>> Keep the foods in sealed holders. Micro-organisms may spread out of unsealed food items and cause bad odour.
- Remove any expired or spoiled foods from the product.

**The door is not closing.**

- Food packages may be blocking the door. >>> Relocate any items blocking the doors.
- The product is not standing in full upright position on the ground. >>> Adjust the stands to balance the product.
- The surface is not flat or durable >>> Make sure the surface is flat and sufficiently durable to bear the product.

**The crisper is jammed.**

- The food items may be in contact with the upper section of the drawer. >>> Re-organize the food items in the drawer.

**Temperature on the product surface.**

- High temperature may be observed between two doors, on the side panels and on the rear grill area while your product is operated. This is normal and it does not require servicing.

**Fan continues to operate when the door is opened.**

- Fan may continue to operate when the freezer door is open.

If the problem persists after following the instructions in this section, contact your vendor or an Authorized Service. Do not try to repair the product. This is normal.

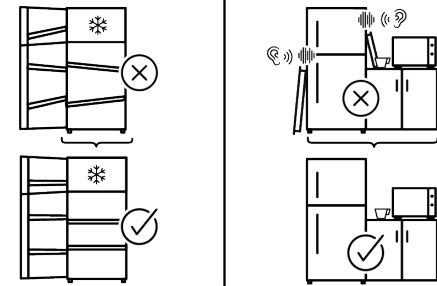
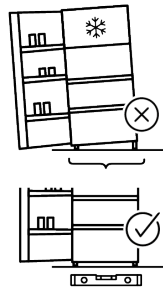
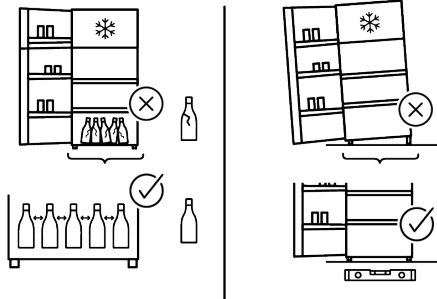
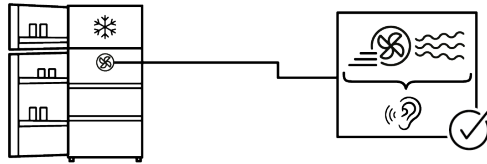
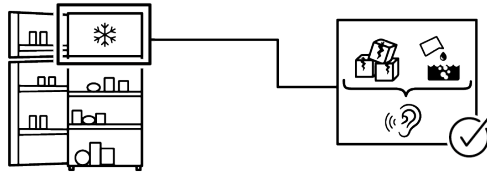
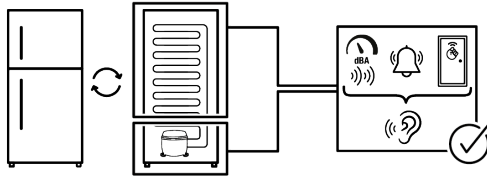

## DISCLAIMER

---

Some (simple) failures can be adequately handled by the end-user without any safety issue or unsafe use arising, provided that they are carried out within the limits and in accordance with the following instructions (see the "Self-Repair" section).

Therefore, unless otherwise authorized in the "Self-Repair" section below, repairs shall be addressed to registered professional repairers in order to avoid safety issues. A registered Professional repairer is a professional repairer that has been granted access to the instructions and spare parts list of this product by the manufacturer according to the methods described in legislative acts pursuant to Directive 2009/125/EC.

**However, only the service agent (i.e. authorized professional repairers) that you can reach through the phone number given in the user manual/warranty card or through your authorized dealer may provide service under the guarantee terms. Therefore, please be advised that repairs by professional repairers (who are not authorized by) Whirlpool shall void the guarantee.**

### Self-Repair

Self-repair can be done by the end-user with regard exclusively to the following spare parts: door handles, door hinges, trays, baskets and door gaskets (an updated list is also available <https://parts-selfservice.europeanappliances.com> as of 1st March 2021).

Moreover, to ensure product safety and to prevent risk of serious injury, the mentioned self-repair shall be done following the instructions in the user manual for self-repair or which are available in <https://parts-selfservice.europeanappliances.com>. For your safety, unplug the product before attempting any self-repair.

Repair and repair attempts by end-users for parts not included in such list and/or not following the instructions in the user manuals for self-repair or which are available in

<https://parts-selfservice.europeanappliances.com>, might give rise to safety issues not attributable to Whirlpool, and will void the warranty of the product.

Therefore, it is highly recommended that end-users refrain from the attempt to carry out repairs falling outside the mentioned list of spare parts, contacting in such cases authorized professional repairers or registered professional repairers. On the contrary, such attempts by end-users may cause safety issues and damage the product and subsequently cause fire, flood, electrocution and serious personal injury to occur.

By way of example, but not limited to, the following repairs must be addressed to authorized professional repairers or registered professional repairers: compressor, cooling circuit, main board, inverter board, display board, etc.

The manufacturer/seller cannot be held liable in any case where end-users do not comply with the above.

The spare part availability of the refrigerator that you purchased is 10 years. During this period, original spare parts will be available to operate the refrigerator properly. The minimum duration of guarantee of the refrigerator that you purchased is 24 months.

This product is equipped with a lighting source of the "G" energy class.

The lighting source in this product shall only be replaced by Professional repairer.

