

ARG 137/A+

12NC: 859991013530

GTIN (EAN) code: 8003437041488

Whirlpool

SENSING THE DIFFERENCE

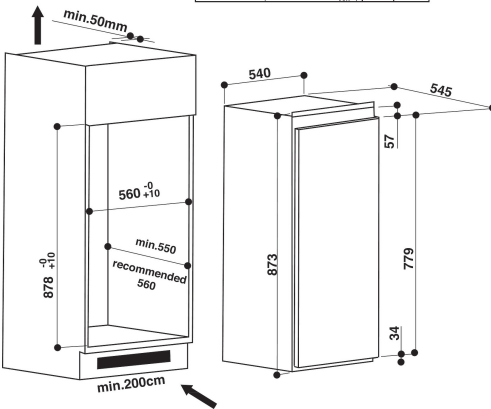
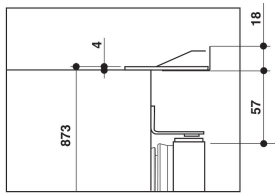

MAIN FEATURES

Product group	Refrigerator
Commercial code	ARG 137/A+
GTIN (EAN) code	8003437041488
Construction type	Built-in
Installation type	Half-integrated
Type of control	Electronic
Type of control settings	LED
Main colour of product	Steel
Electrical connection rating (W)	75
Current (A)	13
Voltage (V)	220-240
Frequency (Hz)	50
Length of Electrical Supply Cord (cm)	200
Plug type	UK
Total unit net capacity (l)	137
Star Rating	Automatic
Number of independent cooling systems	1
Height of the product	873
Width of the product	540
Depth of the product	545
Depth with open door 90 degree (mm)	-
Maximum adjustability feet	0
Net weight (kg)	33
Door hinge	Right reversible

TECHNICAL FEATURES

Temperature adjustable	Yes
Warning signal / Malfunction	Visual
Defrost process fridge section	Automatic
Fast cooling possibility	N/A
Interior ventilator fridge section	No
Shelves for Bottles	No
Lockable door	-
Number of shelves in fridge compartment	3
Number of Adjustable Shelves in fridge compartment	2
Material of the shelves	Glass With Profile
Thermometer fridge section	None

PERFORMANCES

Energy efficiency class - NEW (2010/30/EU)	A+
Energy consumption annual (kWh/annum) - NEW (2010/30/EU)	122
Refrigerator Net capacity (l) - NEW (2010/30/EU)	137
Freezer Net capacity (l) - NEW (2010/30/EU)	0
Freezing capacity (kg/24h) - NEW (2010/30/EU)	0
Temperature rise time (h)	0
Climate class	SN-T
Noise level (dB(A) re 1 pW)	35
Frost free system	No
Maximum ambient temperature	43
Minimum ambient temperature	10