

TGML 660 IX

12NC: 859991635770

GTIN (EAN) code: 8003437625152

Whirlpool

SENSING THE DIFFERENCE



Whirlpool gas hob: 4 gas burners - TGML 660 IX

Standard Whirlpool technologies and features for you to enjoy.



MultiLevel Flame

9 flame levels for different cooking methods. Always get the ideal flame for your cooking methods, to achieve perfect cooking results effortlessly.



Dishwashable Grids

Keep your hob clean easily and safely thanks to the dishwasher safe grids.

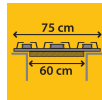

EasyReplace

Install in the 60cm worktop cut-out a 75cm Hob. Maximum versatility in your kitchen



Cast Iron Supports

Cast Iron pan supports for that professional look and maximum stability in use.



Front Controls

Complete control over your cooking. Easily accessible and genuinely intuitive, the controls are conveniently positioned on the front panel of your hob, providing a frictionless cooking experience.



Stainless Steel

For the stylish modern look in your kitchen.

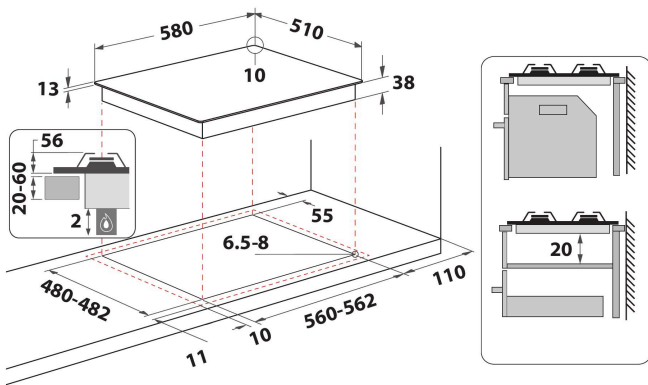

- Cast Iron Pan Supports
- Electromagnetic safety device for each burner
- Silver painted body/Inox cap knobs
- 2 Rectangular Cast Iron grids
- Front controls
- 60 cm hob
- Mechanical control
- Ignition type: knob
- 4 Burners
- 4 burners: 1 Semirapid 1650 W burner, 1 Semirapid 1650 W burner, 1 Rapid 3000 W burner, and 1 Auxiliary 1000 W burner.
- Supply cord included
- Dimensions HxWxD: 56x580x510 mm
- Niche dimensions HxWxD: 60x562x480 mm
- Voltage: 230 V
- Gas Connection Rating: 7300 W

TGML 660 IX

12NC: 859991635770

GTIN (EAN) code: 8003437625152

Whirlpool

SENSING THE DIFFERENCE

MAIN FEATURES

Product group	Hob
Construction type	Built-in
Type of control	Mechanical
Type of control settings	Knob
Number of gas burners	4
Number of electric cooking zones	0
Number of electric plates	0
Number of radiant plates	0
Number of halogen plates	0
Number of induction plates	0
Number of electric warming zones	0
Location of control panel	Front
Basic surface material	Inox
Main colour of product	Inox
Electrical connection rating (W)	0
Gas connection rating (W)	7300
Gas type	Methane
Current (A)	0,6
Voltage (V)	230
Frequency (Hz)	50
Length of Electrical Supply Cord (cm)	85
Plug type	No
Gas connection	Cilindric
Width of the product	580
Height of the product	56
Depth of the product	510
Minimum niche height	20
Minimum niche width	560
Niche depth	480
Net weight (kg)	10.3
Automatic programmes	No

TECHNICAL FEATURES

Power on indicator	No
Number of indicators	0
Type of regulation	Temperature regulated
Type of lid	Without
Residual heat indicator	Without
Main on/off switch	No
Safety device	Yes
Timer	No

PERFORMANCES

Energy input	Gas
--------------	-----