

ARG 108/18 A+/RE

12NC: 859991013620

GTIN (EAN) code: 8003437041518

Whirlpool

SENSING THE DIFFERENCE

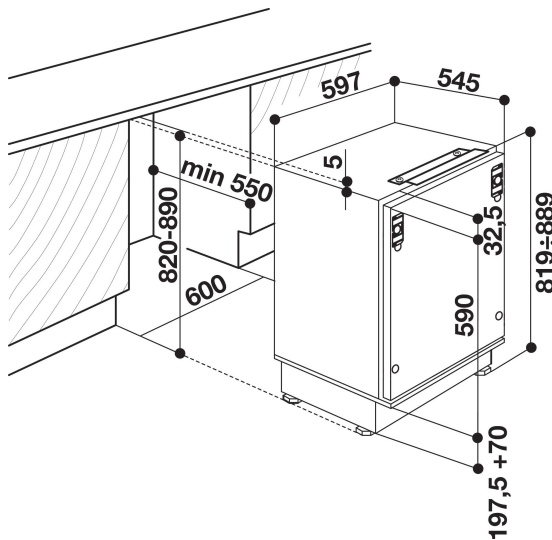

- Energy class: A+
- Total net capacity: 126 l (108 l refrigerator + 18 l freezer)
- Product dimensions (HxWxD): 819x597x545 mm
- Reversible door
- Noise level: 38 dB(A)
- Freezing capacity: 2 Kg/24 h
- Fridge with 4**** freezer
- Temperature adjustable
- Manual defrost system
- Cooling System for Fridge Compartment: Static
- Temperature rise time 14 h
- 3 adjustable balconies
- LED bulb lighting
- 2 drawers
- 3 shelves in fridge compartment
- Mechanical controls
- Annual energy consumption 179 kWh/annum

Whirlpool integrated fridge: white color - ARG 108/18 A+/RE

This Whirlpool integrated Fridge features: dedicated bottle balcony. Under counter fridge.



Auto Defrost

Effortless defrosting. Auto Defrost technology efficiently removes the build-up of ice in the fridge.



Freezer compartment

Ideal storage. This Whirlpool Refrigerator includes a freezer compartment, allowing you to store your frozen goods.



LED lighting

Perfect illumination. Energy-efficient LEDs spread light evenly throughout the refrigerator cavity, making it easier to find what you're looking for.



115 - 185 l capacity

All the space you need. This Whirlpool Refrigerator is designed to provide all the space you need to comfortably store your food and drinks.



Energy class A+

Greater energy efficiency. With its A+ energy rating, this Whirlpool appliance will allow you to enjoy both ideal performance and excellent energy consumption.



Glass shelves

A passion for beauty in every detail. This Whirlpool Refrigerator includes toughened glass shelves with lipped edges that prevent spills, designed to combine beauty and functionality, and providing you the most fulfilling user experience imaginable.



SETMO

Perfect design integration. The SETMO door-to-door mounting system covers your built-in refrigerator, providing total design integration with the rest of your kitchen.



Space Management

All the space you need. This Whirlpool Refrigerator's innovative design provides all the space and flexibility you need to comfortably and easily store your food and drink.



Reversible Door

For your convenience. This Whirlpool Refrigerator features a reversible door, that can be opened from left or right, for your convenience.



Bottle balcony

Safe storage. This Whirlpool Refrigerator provides perfect storage for your bottles, with its dedicated bottle balcony.

ARG 108/18 A+/RE

12NC: 859991013620

GTIN (EAN) code: 8003437041518

Whirlpool

SENSING THE DIFFERENCE

MAIN FEATURES

Product group	Refrigerator
Commercial code	ARG 108/18 A+/RE
GTIN (EAN) code	8003437041518
Construction type	Built-in
Installation type	Built-under
Type of control	Mechanical
Type of control settings	Mechanic
Main colour of product	White
Electrical connection rating (W)	100
Current (A)	13
Voltage (V)	220-240
Frequency (Hz)	50
Length of Electrical Supply Cord (cm)	200
Plug type	UK
Total unit net capacity (l)	126
Star Rating	4
Number of independent cooling systems	1
Height of the product	819
Width of the product	597
Depth of the product	545
Depth with open door 90 degree (mm)	-
Maximum adjustability feet	70
Net weight (kg)	32
Door hinge	Right reversible

TECHNICAL FEATURES

Temperature adjustable	Yes
Warning signal / Malfunction	No signal
Defrost process fridge section	Automatic
Fast cooling possibility	No
Interior ventilator fridge section	No
Shelves for Bottles	No
Lockable door	No
Number of shelves in fridge compartment	3
Number of Adjustable Shelves in fridge compartment	2
Material of the shelves	Glass
Thermometer fridge section	None

PERFORMANCES

Energy efficiency class - NEW (2010/30/EU)	A+
Energy consumption annual (kWh/annum) - NEW (2010/30/EU)	179
Refrigerator Net capacity (l) - NEW (2010/30/EU)	108
Freezer Net capacity (l) - NEW (2010/30/EU)	18
Freezing capacity (kg/24h) - NEW (2010/30/EU)	2
Temperature rise time (h)	14
Climate class	N-ST
Noise level (dB(A) re 1 pW)	38
Frost free system	No
Maximum ambient temperature	0
Minimum ambient temperature	0

ENERGIA - ЕНЕРГИЈА
ENERGIA - ENERGIJA
ENERGY - ENERGIE - ENERGI

179
kWh/annum

108 L **18 L** **38 dB**

2010/1060