

WHSS 90F L T C K

12NC: 859991547200

GTIN (EAN) code: 8003437232046

Whirlpool

SENSING THE DIFFERENCE

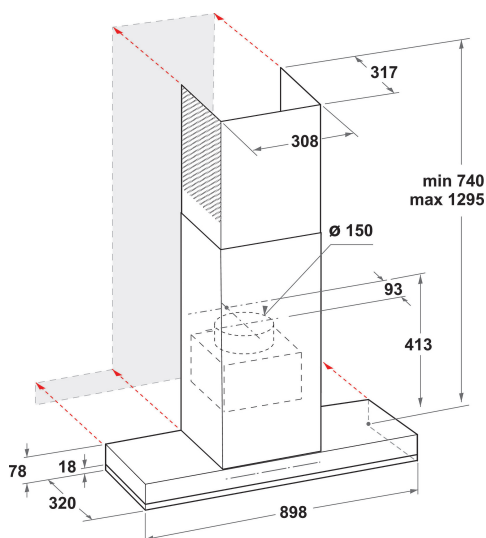

- iXelium finishing
- 6TH Sense technology
- 6thSenseLive: Connectivity
- Maximum noise level 57 dBA
- Noise Level (min. - max.): 43-57 dBA
- Air Flow (min. - max.): 240, 432, booster 779 m3/h
- Maximum extraction rate: 432 (m3/h)
- Energy class A++
- Extraction / Recirculation Rate
%Z_REQ_MAX_OUT_EXTRACTION% / 669 m3/h
- Continuous speed setting
- AirSense
- LightSense
- LightTone
- DimmerLight
- NightLight
- ZenMode

Whirlpool wall mounted cooker hood - WHSS 90F L T C K

This Whirlpool wall mounted Cooker Hood features: black color. Dishwasher-safe, washable aluminium grease filters. An outstanding cooker extractor fan, ensuring a fresh, grease-free cooking environment. Between 60cm and 90cm wide appliance. Exclusive 6th SENSE sensor technology that dynamically adjusts energy consumption, depending on what you are cooking.



6th Sense Live App

The 6thSenseLive App gives the user complete control over the hood, even when out of the house, speeding up cooking times and keeping the air fresh and clean.



Strip LED

Illuminates the cooktop surface at best without any waste of energy.



AirSense

The perfect way to keep a kitchen smelling fresh and clean without any effort. It even continues working after the cooking has stopped. AirSense is able to detect not only cooking odours but also non cooking odours such as cleaning solvents and cigarette smoke etc. Intuitively and automatically activating and adapting to cleanse the air and keep unwanted smells and dirt at bay.



Booster

Odour-free cooking. This Whirlpool Hood features an extraction booster, that ensures ideal air filtration and odour and grease aspiration.



Super Silent

Silent efficiency. This Whirlpool Hood is designed to operate at low noise-levels, so you can enjoy some extra peace and quiet.



WCollection aesthetic

A Masterpiece of Design. Whirlpool understands the importance of craftsmanship and carefully honed details. The timeless design of the W Collection complements any style of kitchen, while the matching appliances blend seamlessly with each other to create a sublimely eye-catching coordinated look. Even the gleaming finishes are engineered for easy cleaning, so fingerprints and smudges become a thing of the past. From the platinum chromed logo to the tinted glass and sophisticated edge-to-edge metal band, every detail has been designed to delight and enhance the overall Whirlpool experience.



Total annual energy consumption

Ideal performance, outstanding savings. Whirlpool Hoods are designed to provide exceptional results, while reducing energy costs.

WHSS 90F L T C K

12NC: 859991547200

GTIN (EAN) code: 8003437232046

Whirlpool

SENSING THE DIFFERENCE

MAIN FEATURES

Product group	Hood
Colour body	Black
Material body	Stainless steel
Colour chimney	Black
Material chimney	Stainless steel
Typology	Half automatic
Installation type	Wall-mounted
Type of control	Electronic
Type of control settings	-
Decor panel options	N/A
Motor location	Integrated motor in hood chimney
Operating Mode	Convertible
Electrical connection rating (W)	167
Current (A)	0,7
Voltage (V)	220-240
Frequency (Hz)	50/60
Length of Electrical Supply Cord (cm)	150
Plug type	Schuko
Chimney height (mm)	-
Height of product, without chimney (mm)	413
Height of the product	1100
Width of the product	898
Depth of the product	320
Minimum niche height	0
Minimum niche width	0
Niche depth	0
Net weight (kg)	25.5

TECHNICAL FEATURES

Type of manual control devices	Touch control
Type of automatic control devices	-
Number of motors	1
Total power of the motors (W)	160
Number of speed settings: boost option availability	Continuous
Boost presence	Yes
Maximum output air extraction (m ³ /h)	779
Boost position air extraction (m ³ /h)	779
Maximum output recirculating air (m ³ /h)	669
Boost position output recirculating (m ³ /h)	669
Light Control Type	Continuous
Number of lights	1
Type of lamps used	Strip LED
Total power of the lamps (W)	7
Diameter of air outlet (mm)	150
No-return airflow flap	No
Grease filter material	Washable aluminium
Odour filter	Yes

PERFORMANCES

Sound power at min. speed (2010/30/EU)	43
Sound power at max. speed (2010/30/EU)	57
Noise level with boost position (dB(A) re 1 pW)	55

