

WMW57DMB

12NC: 859991679730

GTIN (EAN) code: 8003437396960

Whirlpool

SENSING THE DIFFERENCE

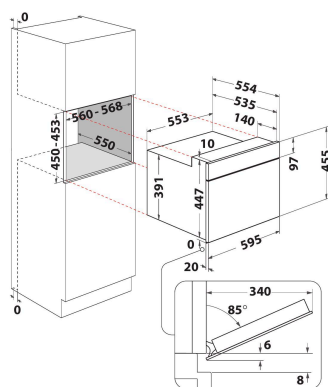

MAIN FEATURES

Product group	Mikrovalna pećnica
Commercial code	WMW57DMB
Main colour of product	Crna
Type of micro-wave oven	MW-Combi
Construction type	Ugradbeni
Type of control	Electronic
Type of control settings	LCD
Additional cooking method Grill	Yes
Funkcija Crisp	Yes
Steam	Ne
Additional cooking method Fan cooking	Yes
Clock	Yes
Automatic programmes	Yes
Height of the product	455
Width of the product	595
Depth of the product	560
Minimum niche height	450
Minimum niche width	556
Niche depth	550
Net weight (kg)	30.8
Ljubičasta sa bisernim odsjajem	40
Turntable	Yes
Turntable diameter (mm)	360
Integrated Cleaning system	Ne

TECHNICAL FEATURES

Current (A)	16
Voltage (V)	230
Frequency (Hz)	50
Length of Electrical Supply Cord (cm)	135
Plug type	Schuko
Timer	Ne
Grill power (W)	1600
Type of grill	Heating element
Funkcija Crisp	Stainless steel
Interior light	Yes
Additional cooking method Grill	Yes
Position of interior lights of the cavity	Funkcija Jet menu steam

ENERGY LABEL

6th Sense / Dynamic Intelligence	Tehnologija 6.ČULO
Number of power levels	7
Maximum micro-wave power (W)	900
Funkcija Bread defrost	Yes
Funkcija Jet defrost	Yes
Funkcija Jet Start	Yes