

PMW 75D2/IXL

12NC: 859991546910

GTIN (EAN) code: 8003437231957

Whirlpool

SENSING THE DIFFERENCE

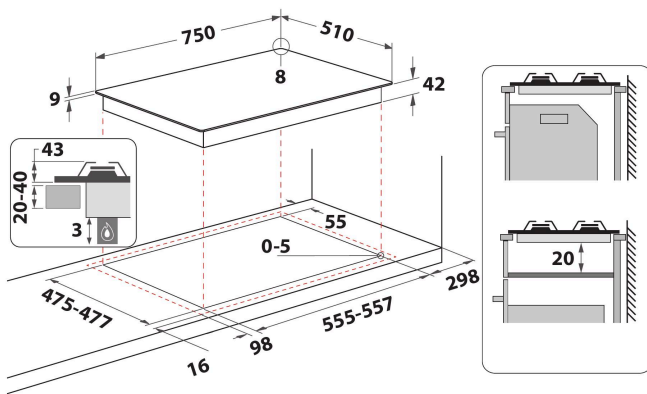

- Cast Iron Pan Supports
- Electromagnetic safety device for each burner
- Brushed chrome knobs
- 3 W Collection PreciseFlame Cast Iron grids
- Front controls
- 75 cm hob
- Ignition type: knob
- 5 Burners
- 5 burners: 1 FTGH Auxiliary 1000 W burner, 1 FTGH Semi-Fast 1900 W burner, 1 FTGH Semi-Fast 1900 W burner, 1 FTGH Auxiliary 1000 W burner, and 1 FTGH Fast 3000 W burner.
- Supply cord included
- Dimensions HxWxD: 40x750x510 mm
- Voltage: 220-240 V
- Gas Type: Only Gas-Methane 20 mBar
- Front left zone: 110 mm \varnothing , FTGH Auxiliary 1000 W

Whirlpool gas hob: 5 gas burners - PMW 75D2/IXL

Standard Whirlpool technologies and features for you to enjoy.



PreciseFlame

Innovative flame system. The unique vertical flame distribution system ensures your pots and pans are heated more efficiently and rapidly, helping you enjoy perfect cooking results.



iXelium

Long lasting shine. The revolutionary iXelium treatment protects your hob from scratches and corrosion, ensuring a perfect shine, always. And, it's easy to clean: all you need is water and a soft cloth.



Booster

Enjoy super fast boiling times with the Booster cooking zone.



Speed to Boil

Enjoy faster boiling. Our innovative technology, by effectively harnessing the energy of the flames, ensures more heat is delivered directly to your pots and pans allowing you to enjoy ideal cooking results, sooner.



Flush design

The flush burners with a PreciseFlame vertical flame heat the base of the pan directly for reduced heat dispersion, which saves gas and increases efficiency. The sleek design stylishly reflects the latest appliance trends, providing a fabulous focal point for any modern kitchen. The flush design of the burners with a maximum height of 10,5 mm ensures the hobs are even easier to clean. Cooktop grids are made of cast iron, a top performing material resistant to high temperatures, durable in time and perfectly transmit heat for outstanding functionality and aesthetics.



Dishwashable Grids

Keep your hob clean easily and safely thanks to the dishwasher safe grids.



Full width cast iron grids

The full-width cast-iron pan support maximises the cooking surface with an edge-to-edge design so pans can slide effortlessly from one burner to another without any lifting and is durable enough to withstand damage and prevent rusting or scratching. Cooktop grids are made of cast iron, a top performing material resistant to high temperatures, durable in time that perfectly transmit heat. Restyled for added comfort and beauty, the distinctive design of the ergonomic knobs ensures easier use, greater control, and easeness of cleaning on steel and glass models.

PMW 75D2/IXL

12NC: 859991546910

GTIN (EAN) code: 8003437231957

Whirlpool

SENSING THE DIFFERENCE

MAIN FEATURES

Product group	Hob
Construction type	Built-in
Type of control	N/A
Type of control settings	Knob
Number of gas burners	5
Number of electric cooking zones	0
Number of electric plates	0
Number of radiant plates	0
Number of halogen plates	0
Number of induction plates	0
Number of electric warming zones	0
Location of control panel	Front
Basic surface material	Inox
Main colour of product	Inox Ixelium
Electrical connection rating (W)	0
Gas connection rating (W)	0
Gas type	Only Gas-Methane 20 mBar
Current (A)	0
Voltage (V)	220-240
Frequency (Hz)	50/60
Length of Electrical Supply Cord (cm)	0
Plug type	No
Gas connection	N/A
Width of the product	750
Height of the product	40
Depth of the product	510
Minimum niche height	0
Minimum niche width	555
Niche depth	475
Net weight (kg)	14.9
Automatic programmes	No

TECHNICAL FEATURES

Power on indicator	No
Number of indicators	0
Type of regulation	Stepless energy regulated
Type of lid	Without
Residual heat indicator	Without
Main on/off switch	No
Safety device	-
Timer	No

PERFORMANCES

Energy input	Gas
--------------	-----