

# AKZ 6200 IX

12NC: 858562001700

EAN code: 8003437937880



SENSING THE DIFFERENCE

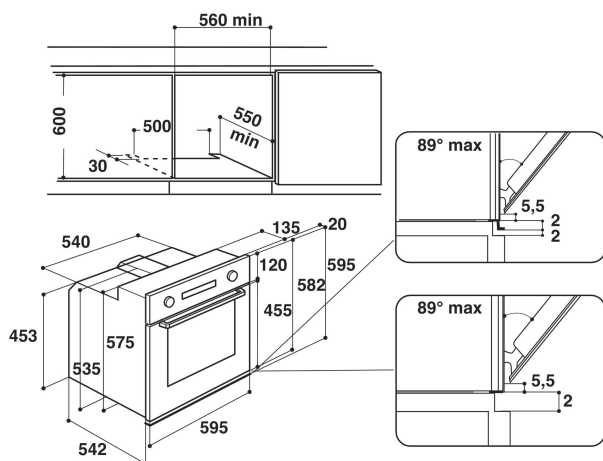

## MAIN FEATURES

Product group	Oven
Commercial code	AKZ 6200 IX
Main colour of product	Inox
Construction type	Вбудована
Type of control	Mechanical and electronic
Type of control setting and signalling devices	-
Are any hobs controls integrated?	Hi
Which kind of hobs can be controlled?	-
Automatic programmes	Yes
Current (A)	16
Voltage (V)	220-240
Frequency (Hz)	50-60
Length of Electrical Supply Cord (cm)	130
Plug type	Hi
Depth with open door 90 degree (mm)	-
Height of the product	595
Width of the product	595
Depth of the product	564
Minimum niche height	0
Minimum niche width	0
Niche depth	0
Net weight (kg)	34
Usable volume (of cavity)	60
Noise level (dB(A) re 1 pW)	0
Integrated Cleaning system	Hydrolytic
Grids	1
Trays	2

## TECHNICAL FEATURES

Timer	Programmable
Time control	Electronic
Time-setting options	Start and Stop
Safety device	-
Interior light	Yes
Number of interior lights	1
Position of interior lights	Rear
Oven guides	Grids
Probe	Hi

## ENERGY LABEL

Energy input	Electric
Type of energy	Electricity
Energy efficiency class - cavity 1	-
Energy consumption conventional (kWh)	0.89
Energy consumption forced air convection (kWh)	0.79