

WOI98MPT2SBA

12NC: 859991679880

GTIN (EAN) code: 8003437836312

Whirlpool

SENSING THE DIFFERENCE

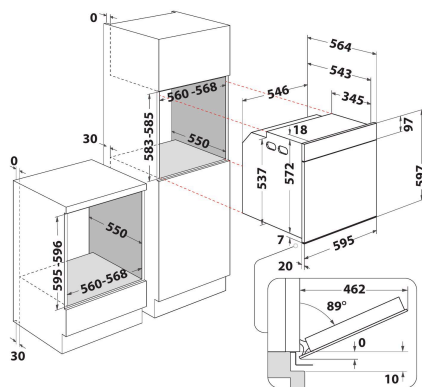

MAIN FEATURES

Product group	Oven
Commercial code	WOI98MPT2SBA
Main colour of product	Черен
Construction type	Built-in
Type of control	Electronic
Type of control settings	-
Are any hobs controls integrated?	No
Which kind of hobs can be controlled?	N/A
Automatic programmes	Yes
Current (A)	16
Voltage (V)	220-240
Frequency (Hz)	50
Length of electrical supply cord (cm)	100
Plug type	No
Depth with open door 90 degree (mm)	-
Height of the product	597
Width of the product	595
Depth of the product	564
Minimum niche height	583
Minimum niche width	560
Niche depth	550
Net weight (kg)	39.3
Usable volume (of cavity)	73
Integrated Cleaning system	Pyrolytic+Hydrolytic
Grids of the cavity	1
Trays	3

TECHNICAL FEATURES

Timer	Yes
Time control	Electronic
Time-setting options	Start and Stop
Safety device	-
Interior light	Yes
Number of interior lights of the cavity	1
Position of interior lights of the cavity	Rear
Oven guides of the cavity	Telescopic
Probe of the cavity	Yes

ENERGY LABEL

Energy input	Electric
Type of energy of the cavity	електрически
Energy efficiency class - NEW (2010/30/EU)	A+
Energy consumption per cycle conventional - NEW (2010/30/EU)	0.64
Energy consumption per cycle forced air convection - NEW (2010/30/EU)	0.87