

GUIDE D'UTILISATION QUOTIDIENNE



MERCI D'AVOIR ACHETÉ UN PRODUIT INDESIT

Afin de recevoir un service et un support complet, merci d'enregistrer votre appareil sur www.indesit.com/register



Vous pouvez télécharger les Consignes de sécurité et le Guide d'utilisation et entretien en visitant notre site Web docs.indesit.eu et en suivant les consignes au dos de ce livret.

! Lire attentivement les Consignes de santé et de sécurité avant d'utiliser l'appareil.

DESCRIPTION DU PRODUIT

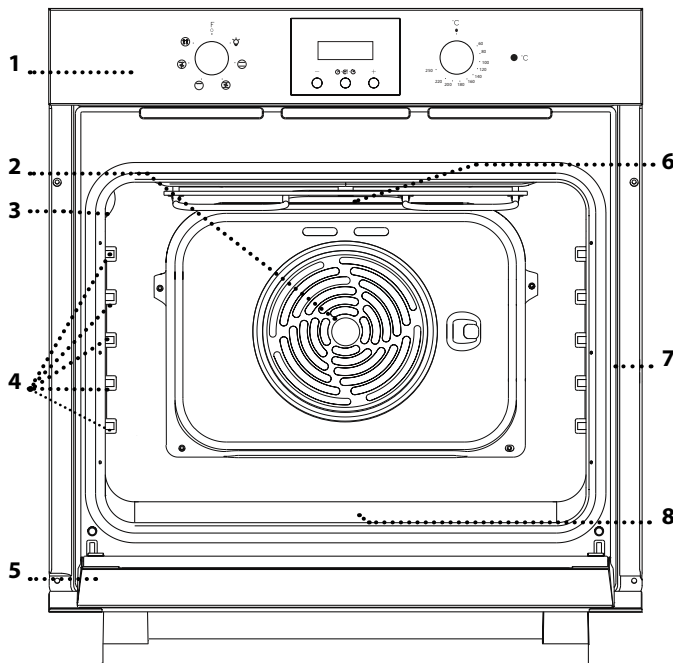

1. Bandeau de commande
2. Ventilateur
3. Lampe
4. Supports de grille
(le niveau est indiqué sur la paroi du compartiment de cuisson)
5. Porte
6. Élément chauffant supérieur/gril
7. Plaque signalétique
(ne pas enlever)
8. Élément chauffant inférieur
(invisible)

PANNEAU DE COMMANDES

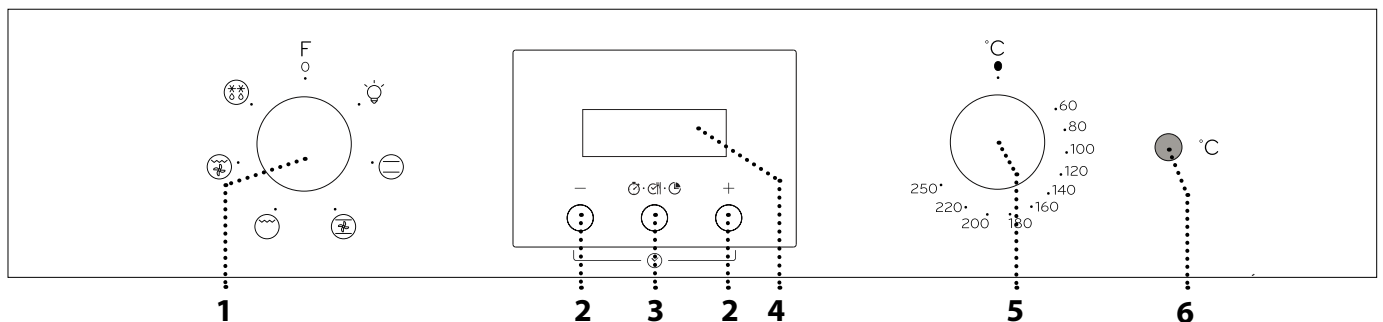

1. BOUTON DE SÉLECTION

Pour allumer le four en sélectionnant une fonction. Tournez à la position 0 pour éteindre le four.

2. TOUCHE +/-

Pour diminuer ou augmenter la valeur affichée à l'écran

3. TOUCHE HEURE

Pour sélectionner les différents réglages : durée, fin de cuisson, minuterie.

4. ÉCRAN

5. BOUTON THERMOSTAT

Tournez pour sélectionner la température désirée.

6. VOYANT THERMOSTAT / PRÉCHAUFFAGE

S'allume pendant le processus de chauffage. S'éteint une fois la température désirée atteinte.

ACCESSOIRES



Pour plus d'information, téléchargez le Guide d'utilisation et d'entretien à partir de docs.indesit.eu

GRILLE MÉTALLIQUE

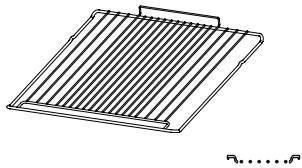

LÈCHEFRITE (SELON LE MODÈLE)

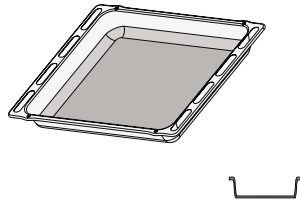

PLAQUE DE CUISSON

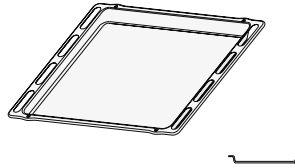

Le nombre et type d'accessoires peuvent varier selon le modèle acheté. Il est possible d'acheter séparément d'autres accessoires auprès du Service Après-Vente.

UTILISER LES ACCESSOIRES

• Insérez la grille métallique au niveau désiré en la tenant légèrement inclinée vers le haut et en déposant la partie surélevée arrière (pointant vers le haut) en premier. Glissez-la ensuite horizontalement sur le support de grille aussi loin que possible.

Les autres accessoires, comme la plaque de cuisson, sont insérés horizontalement en les glissant le long des supports de grille.

Les supports de grille peuvent être enlevés pour faciliter le nettoyage du four : tirez pour les enlever de leurs appuis.

FONCTIONS



Pour plus d'information, téléchargez le Guide d'utilisation et d'entretien à partir de docs.indesit.eu



OFF

Pour éteindre le four.



ÉCLAIRAGE

Pour allumer l'ampoule dans le compartiment.



CONVECTION NATURELLE

Pour cuire tout type de plat sur une seule grille. Il est conseillé d'utiliser le 2e niveau.



CONVECTION FORCÉE

Pour la cuisson de gâteaux avec garniture liquide sur un seul niveau. Cette fonction convient également aux cuissons sur deux gradins. Changez la position des plats pour cuire les aliments de manière plus uniforme.



GRILL

Pour cuire des biftecks, des brochettes, et des saucisses, faire gratiner des légumes et griller du pain. Pour la cuisson de la viande, nous vous conseillons d'utiliser une plaque de cuisson pour recueillir les jus de cuisson : Placez la lèche-frite, contenant 200 ml d'eau, sur n'importe quel niveau sous la grille métallique.



GRATIN

Pour griller de gros morceaux de viande (gigots, rôti de bœuf, poulets). Nous vous conseillons d'utiliser une lèche-frite pour recueillir les jus de cuisson : Placez la lèche-frite, contenant 200 ml d'eau, sur n'importe quel niveau sous la grille métallique.



DÉCONGÉLATION

Pour décongeler les aliments plus rapidement.

UTILISER L'APPAREIL POUR LA PREMIÈRE FOIS

1. RÉGLAGE DE L'HEURE

Vous devez régler l'heure lorsque vous allumez l'appareil pour la première fois : « AUTO » et « 0.00 » clignotent à l'écran.



Pour régler l'heure, appuyez sur les touches — et ++ en même temps : Réglez l'heure à l'aide des touches + et —.

Veillez noter: Pour changer l'heure par la suite (par exemple après une panne de courant prolongée), vous devez réinitialiser l'heure en appuyant sur les touches — et + en même temps.

2. RÉGLER LA TONALITÉ

Après avoir sélectionné l'heure désiré, appuyez sur la *touche heure* : L'affichage indique « bip 1 ».



Pour sélectionner la tonalité désirée, appuyez sur la touche —, appuyez ensuite sur la *touche heure* pour confirmer.

Veillez noter: Pour changer les réglages par la suite, appuyez sur les touches — et + en même temps et répétez les opérations décrites plus haut.

3. CHAUFFER LE FOUR

Un nouveau four peut dégager des odeurs provenant de la fabrication : ceci est parfaitement normal. Avant de cuire des aliments, nous vous conseillons de chauffer le four à vide pour éliminer les odeurs. Enlevez les cartons de protection ou les pellicules transparentes du four, et enlevez les accessoires qui se trouvent à l'intérieur.

Chauffez le four à 250 °C pour environ une heure en utilisant la fonction « Convection forcée ». Le four doit être vide durant cette opération.

Suivez les directives pour régler correctement la fonction.

Veillez noter: Nous vous conseillons d'aérer la pièce après avoir utilisé l'appareil pour la première fois.

UTILISATION QUOTIDIENNE

1. SÉLECTIONNER UNE FONCTION

Pour sélectionner une fonction, tournez le *bouton de sélection* sur le voyant de la fonction désirée.

2. ACTIVER UNE FONCTION

Pour lancer la fonction que vous avez sélectionnée, tournez le *bouton du thermostat* pour régler la température requise.

Pour interrompre la fonction en tout temps ou éteindre le four, tournez le *bouton de sélection* et le *bouton de thermostat* à 0 et ●.

3. PRÉCHAUFFAGE

Une fois la fonction lancée, le voyant du thermostat s'allume pour vous indiquer que le préchauffage est en cours.

À la fin du processus, le voyant du thermostat s'éteint pour vous indiquer que le four a atteint la température désirée : vous pouvez maintenant placer les aliments à l'intérieur et débuter la cuisson.

Veillez noter: Placer les aliments dans le four avant que le préchauffage soit terminé peut affecter la cuisson.

. PROGRAMMER LA CUISSON

après avoir sélectionné et activé la fonction, il est possible de régler la durée.



Appuyez sur la *touche heure* pendant au moins 2 secondes : le voyant 🔔 clignote.



Appuyez sur la *touche heure* de nouveau : DUR et 0.00 s'affiche à l'écran un à la suite de l'autre pendant que AUTO 🔔 clignote.

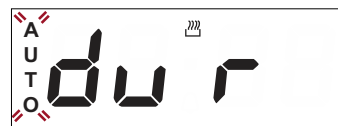

Réglez la durée à l'aide des touches + et —. Après quelques secondes, l'écran affiche l'heure alors qu'AUTO 🔔 reste allumé, confirmant le réglage.



Veillez noter: Pour voir le temps de cuisson restant, appuyez sur la **touche heure** pendant au moins 2 secondes. Pour le changer, au besoin, appuyez de nouveau en utilisant les touches + et - pour modifier la durée.

FIN DE CUISSON

À la fin de la cuisson, le voyant  s'éteint, une alarme sonore retentit, et AUTO clignote à l'écran.



Appuyez sur une touche quelconque pour désactiver l'alarme.

Retournez le bouton de fonction et le *bouton Thermostat* à 0 et ●, appuyez ensuite sur la *touche heure* pour au moins 2 secondes pour éteindre le four.



RÉGLER LA MINUTERIE

Cette option n'interrompt pas ou ne lance pas la cuisson, mais vous permet d'utiliser l'écran comme minuterie, durant le fonctionnement d'une fonction ou quand le four est éteint.

Pour activer la minuterie, appuyez sur la *touche heure* pendant au moins 2 secondes : le  voyant clignote à l'écran.



























































Utilisez les touches + et - pour régler la durée désirée : le compte à rebours démarre après quelques secondes.







L'écran affiche l'heure et le  reste allumé, confirmant que la minuterie a été réglée.

Veillez noter: Pour afficher le compte à rebours et le changer, au besoin, appuyez de nouveau sur la *touche heure* pendant au moins 2 secondes.

TABLEAU DE CUISSON

RECETTE	FONCTION	PRECHAUF-FER	TEMPÉRATURE (°C)	DURÉE (MIN)	NIVEAU ET ACCESSOIRES
Gâteaux à pâte levée		Oui	150 - 170	30 - 90	2 
		Oui	150 - 170	30 - 90 ***	4 1  
Gâteau fourré (gâteau au fromage, strudel, tarte aux fruits)		Oui	160 - 200	35 - 90	2 
		Oui	160 - 200	35 - 90 ***	4 2  
Biscuits/tartelettes		Oui	160 - 180	15 - 35	2 / 3 
		Oui	150 - 170	20 - 40 ***	4 2  
Chouquettes		Oui	180 - 200	40 - 60	2 
		Oui	170 - 190	35 - 50 ***	4 2  
Meringues		Oui	90	150 - 200	2 
		Oui	90	140 - 200 ***	4 2  
Pizza/Focaccia		Oui	220 - 250	10 - 25	1 / 2 
		Oui	200 - 240	15 - 30 ***	4 2  
Pain 80 g		Oui	180 - 200	30 - 45	2 
Pain 500 kg		Oui	180	50 - 70	1 / 2 
Pain		Oui	180 - 200	30 - 80 ***	4 2  
		Oui	250	10 - 20	2 
Pizzas surgelées		Oui	250	10 - 20 ***	4 2  
		Oui	180 - 200	30 - 45	2 
Quiches et tartes salés (tarte aux légumes, quiche)		Oui	170 - 190	40 - 60 ***	4 2  
		Oui	190 - 200	20 - 30	2 
Vol-au-vent/biscuits à pâte feuilletée		Oui	180 - 190	15 - 40 ***	4 2  
		Oui	190 - 200	45 - 65	2 
Lasagnes/pâtes au four/cannellonis/tartes		Oui	190 - 200	80 - 110	2 

FONCTIONS				
	Convection naturelle	Grill	Gratin	Convection forcée

ACCESSOIRES					
	Grille métallique	Plaque de cuisson ou moule à gâteau sur la grille métallique	Plaque de cuisson/lèche-frite ou plat de cuisson sur grille métallique	Lèche-frite / Plaque de cuisson	Lèche-frite / Plaque de cuisson contenant 200 ml d'eau

RECETTE	FONCTION	PRECHAUF-FER	TEMPÉRATURE (°C)	DURÉE (MIN)	NIVEAU ET ACCESSOIRES
Rôti de porc avec grattons 2 kg		Oui	180 - 190	110 - 150	2
Poulet/lapin/canard 1 kg		Oui	200 - 230	50 - 100	2
Dinde/oie 3 kg		Oui	180 - 200	150 - 200	2
Poisson au four/en papillote 0.5 (filet, entier)		Oui	170 - 190	30 - 45	2
Légumes farcis (tomates, courgettes, aubergines)		Oui	180 - 200	50 - 70	2
Pain grillé		5'	250	2 - 6	5
Filets/tranches de poisson		5'	250	15 - 30 *	4 3
Saucisses/brochettes/côtes levées/hamburgers		5'	250	15 - 30 *	5 4
Poulet rôti 1 - 1,3 kg		-	200 - 220	60 - 80 **	3 1
Rôti de bœuf saignant 1 kg		-	200	35 - 50 **	3
Gigot d'agneau/jarret		-	200	60 - 90 **	3
Pom. terre rôties		-	200 - 220	35 - 55 **	3
Gratin de légumes		-	200 - 220	25 - 55	3
Lasagnes & viande		Oui	200	50 - 100 ****	4 1
Viandes et pommes de terre		Oui	190 - 200	45 - 100 ****	4 1
Poisson et légumes		Oui	180	30 - 50 ****	4 2

La durée de cuisson ne comprend pas la phase de préchauffage : Nous vous conseillons de placer les aliments dans le four et régler le temps de cuisson seulement après avoir atteint la température désirée.

* Tourner les aliments à mi-cuisson.

** Au besoin, retournez les aliments aux deux tiers de la cuisson).

*** Changez les niveaux à la mi-cuisson.

**** Temps approximatif : les plats peuvent être retirés en tout temps, selon vos préférences personnelles. Changez les niveaux aux deux tiers de la cuisson si nécessaire.

Téléchargez le Guide d'utilisation et d'entretien sur docs.indesit.eu pour obtenir le tableau de recettes testées, compilé pour les autorités de certification, conformément à la norme CEI 60350-1.

FONCTIONS				
	Convection naturelle	Grill	Gratin	Convection forcée
ACCESSOIRES				
	Grille métallique	Plaque de cuisson ou moule à gâteau sur la grille métallique	Plaque de cuisson/lèche-frite ou plat de cuisson sur grille métallique	Lèche-frite / Plaque de cuisson
				Lèche-frite / Plaque de cuisson contenant 200 ml d'eau



N'utilisez pas d'appareil de nettoyage à vapeur.

Utilisez des gants de protection lors des opérations.

Effectuez les opérations nécessaires lorsque le four est froid.

Débranchez l'appareil de l'alimentation électrique.

N'utilisez pas de laine d'acier, de tampons à récurer abrasifs, ou des détergents abrasifs ou corrosifs, ils pourraient endommager les surfaces de l'appareil.

SURFACES EXTÉRIEURES

Nettoyez les surfaces à l'aide d'un chiffon en microfibre humide. Si elles sont très sales, ajoutez quelques gouttes de détergent à pH neutre. Essayez avec un chiffon sec.

N'utilisez pas de détergents corrosifs ou abrasifs. Si l'un de ces produits entre en contact avec des surfaces de l'appareil, nettoyez immédiatement à l'aide d'un chiffon en microfibre humide.

SURFACES INTÉRIEURES

• Après chaque utilisation, laissez le four refroidir et nettoyez-le, de préférence lorsqu'il est encore tiède, pour enlever les dépôts ou taches laissés par les résidus de nourriture. Pour enlever la condensation qui se serait formée lors de la cuisson d'aliments avec une forte teneur en eau, laissez le four refroidir complètement et essuyez-le avec un chiffon ou une éponge.

ENLEVER ET RÉINSTALLER LA PORTE

1. Pour enlever la porte, ouvrez-la complètement et abaissez les loquets jusqu'à ce qu'ils soient déverrouillés.

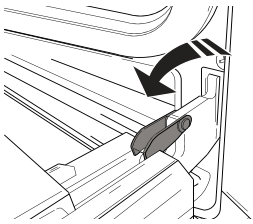

2. Fermez le plus possible la porte.

Tenez la porte fermement avec les deux mains – ne la tenez pas par la poignée. Enlevez simplement la porte en continuant à la fermer tout en la tirant vers le haut (a) jusqu'à ce qu'elle soit dégagée de ses appuis (b).

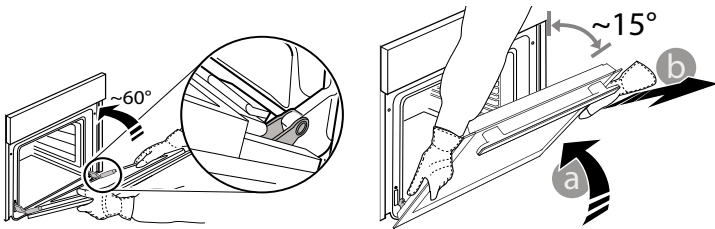

Placez la porte de côté, l'appuyant sur une surface souple.

3. Réinstallez la porte en la plaçant devant le four pour aligner les crochets des charnières avec leurs appuis et attacher la partie supérieure sur son appui.

4. Abaissez la porte pour ensuite l'ouvrir complètement. Abaissez les loquets dans leur position originale : assurez-vous de les abaisser complètement.

5. Essayez de fermer la porte et assurez-vous qu'elle est alignée avec le panneau de commande. Sinon, répétez les étapes précédentes.

- La porte peut facilement être enlevée et replacée pour faciliter le nettoyage de la vitre .
- Nettoyez le verre dans la porte avec un détergent liquide approprié.
- L'élément chauffant supérieur du gril peut être baissé pour nettoyer la paroi supérieure du four : Retirez l'élément chauffant de son appui, ensuite abaissez-le. Pour replacer l'élément chauffant, soulevez-le, tirez légèrement vers l'avant, et assurez-vous que l'onglet de soutien est dans son appui.

ACCESSOIRES

Faites tremper les accessoires dans de l'eau contenant un détergent à vaisselle, utilisez des gants de cuisine s'ils sont encore chauds. Utilisez une brosse à vaisselle ou une éponge pour enlever les résidus d'aliments.

CLICK & CLEAN - NETTOYER LA VITRE

1. Après avoir enlevé la porte et l'avoir placée sur une surface matelassée, les poignées vers le bas, appuyez sur les deux fermetures en même temps et enlevez le bord supérieur de la porte en la tirant vers vous.

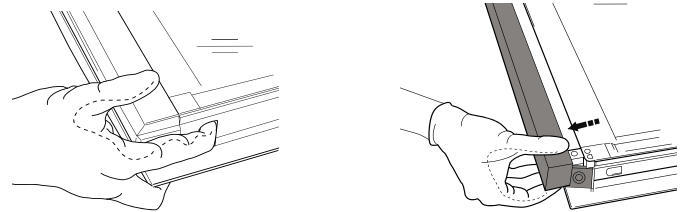

2. Soulevez et tenez fermement la vitre intérieure avec les deux mains, enlevez-la et placez-la sur une surface matelassée avant de la nettoyer.

3. Pour bien replacer la vitre intérieure, assurez-vous que le « R » est visible dans le coin gauche. En premier, insérez la longue partie de la vitre marquée d'un « R » dans les appuis des guides, abaissez-la ensuite en place.

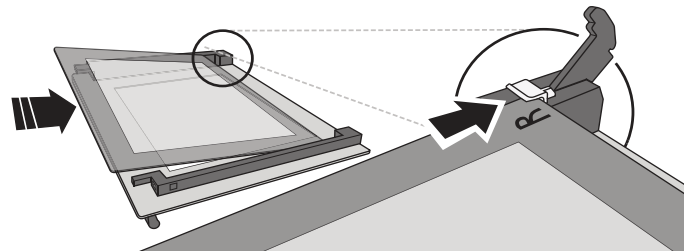

4. Remplacez le bord supérieur : un déclic indique le positionnement correct. Assurez-vous que le joint est bien placé avant de replacer la porte.

Problème	Cause possible	Solution
Le four ne fonctionne pas.	Coupure de courant. Débranchez de l'alimentation principale.	Assurez-vous qu'il n'y a pas de panne de courant et que le four est bien branché. Éteignez puis rallumez le four pour voir si le problème persiste.

CONSEILS UTILES



Pour plus d'information, téléchargez le Guide d'utilisation et d'entretien à partir de docs.indesit.eu

COMMENT LIRE LE TABLEAU DE CUISSON

Le tableau indique la meilleure fonction, les accessoires, et le niveau à utiliser pour la cuisson des différents types d'aliments. Les temps de cuisson commencent au moment de l'introduction du plat dans le four et ne tiennent pas compte du préchauffage (s'il est nécessaire). Les températures et temps de cuisson sont approximatifs et dépendent de la quantité d'aliments et du type d'accessoire. Pour commencer, utilisez les valeurs conseillées les plus basses, et si les aliments ne sont pas assez cuits, augmentez-les. Utilisez les accessoires fournis, et de préférence des moules à gâteau en métal foncés et des plats de cuisson. Vous pouvez aussi utiliser des plaques et accessoires en pyrex ou en céramique ; cependant, les temps de cuisson seront sensiblement plus longs.

CUIRE DES ALIMENTS DIFFÉRENTS EN MÊME TEMPS

La fonction « Convection forcée » permet de cuire en même temps plusieurs aliments nécessitant la même température de cuisson (comme le poisson et les légumes) sur différentes grilles. Changez les niveaux aux deux tiers de la cuisson si nécessaire. Enlevez les aliments qui demandent moins de cuisson et laissez dans le four les aliments qui ont besoin de plus de cuisson.

FICHE TECHNIQUE

La fiche technique, incluant les taux d'efficacité énergétique du four, peut être téléchargée sur notre site Web docs.indesit.eu

COMMENT OBTENIR LE GUIDE D'UTILISATION ET ENTRETIEN

> Téléchargez le Guide d'utilisation et d'entretien sur notre site Web docs.indesit.eu (vous pouvez utiliser ce code QR), en précisant le code commercial du produit.



> Une autre façon est de contacter notre Service Après-vente

CONTACTER LE SERVICE APRÈS-VENTE

Vous pouvez trouver les informations pour nous contacter dans le livret de garantie. Lorsque vous contactez notre Service Après-vente, veuillez indiquer les codes disponibles sur la plaque signalétique de l'appareil.

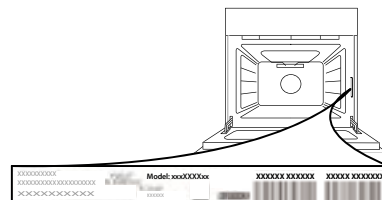

GUIDA RAPIDA



GRAZIE PER AVER ACQUISTATO UN PRODOTTO INDESIT

Per ricevere un'assistenza più completa, registrare il prodotto su www.indesit.com/register



Scaricare le istruzioni per la sicurezza e le istruzioni per l'uso collegandosi al sito docs.indesit.eu e seguire la procedura indicata sul retro.

! Leggere attentamente le istruzioni per la sicurezza prima di utilizzare il prodotto

DESCRIZIONE PRODOTTO

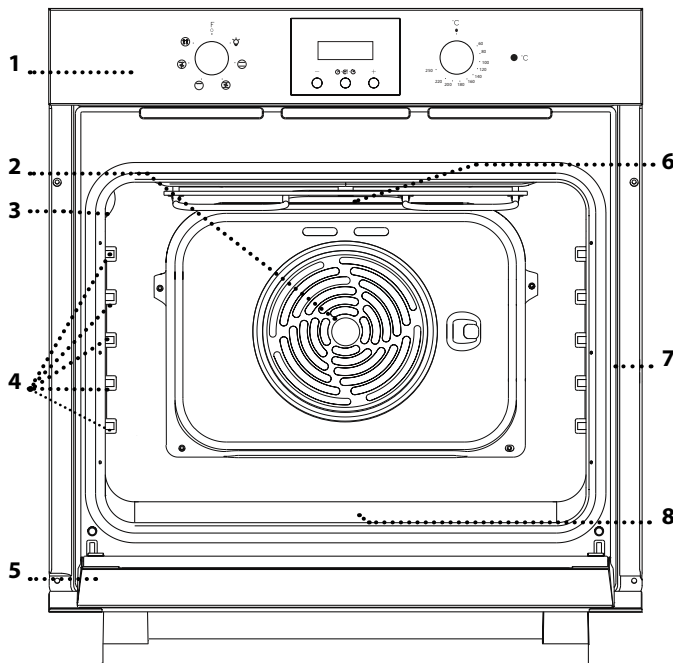

1. Pannello di controllo
2. Ventola
3. Lampada
4. Griglie laterali (il livello è indicato sulla parete della cavità)
5. Porta
6. Resistenza superiore / grill
7. Targhetta matricola (da non rimuovere)
8. Resistenza inferiore (non visibile)

PANNELLO DI CONTROLLO

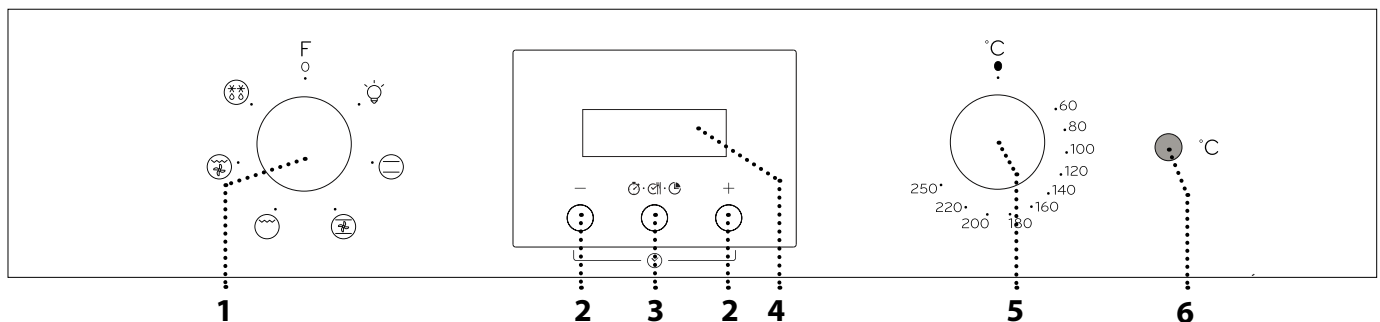

1. MANOPOLA DI SELEZIONE

Per accendere il forno selezionando una funzione. Per spegnere il forno, ruotare sulla posizione O.

2. TASTO +/-

Per aumentare o diminuire il valore visualizzato sul display.

3. TASTO DI REGOLAZIONE DEL TEMPO

Per selezionare le impostazioni di durata, fine cottura, timer.

4. DISPLAY

5. MANOPOLA TERMOSTATO

Ruotare per selezionare la temperatura desiderata.

6. SPIA TERMOSTATO/ PRERISCALDAMENTO

Si accende durante la fase di riscaldamento. Si spegne al raggiungimento della temperatura desiderata.

GRIGLIA

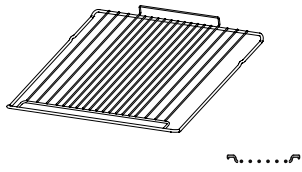

LECCARDA (SE PRESENTE)

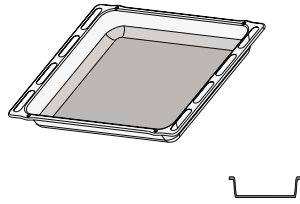

TEGLIA

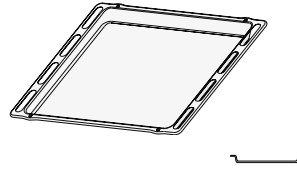

Il numero e il tipo di accessori possono variare a seconda del modello acquistato. È possibile acquistare separatamente altri accessori presso il Servizio Assistenza Clienti.

USO DEGLI ACCESSORI

• Inserire la griglia tenendola leggermente inclinata verso l'alto, appoggiando dapprima il lato posteriore rialzato - orientato verso l'alto - sul livello desiderato. In seguito, farla scivolare orizzontalmente sulla griglia laterale fino a fine corsa.

Gli altri accessori, come la teglia, si inseriscono orizzontalmente facendoli scivolare sulle guide laterali.

Per facilitare la pulizia del forno è possibile rimuovere le guide laterali, tirandole in modo da estrarle dalle sedi.

FUNZIONI

OFF
Per spegnere il forno.

LAMPADA
Per accendere la luce nel forno.

STATICO
Per cuocere qualsiasi tipo di pietanza su un solo ripiano. Si consiglia di utilizzare il 2° livello.

VENTILATO
Per la cottura di dolci con ripieno liquido su un unico ripiano. Questa funzione può essere utilizzata anche per cotture su due ripiani. Invertire la posizione degli alimenti per ottenere una cottura più omogenea.

GRILL
Per grigliare costate, spiedini e salsicce, gratinare verdure o dorare il pane. Quando si cuoce la carne alla griglia, si consiglia di utilizzare una leccarda per raccogliere il liquido di cottura: posizionarla un livello sotto la griglia e aggiungere 200 ml di acqua potabile.

GRATIN
Per arrostitire grossi pezzi di carne (cosciotti, roast beef, polli). Si consiglia di utilizzare una teglia per raccogliere il liquido di cottura: posizionarla un livello sotto la griglia e aggiungere 200 ml di acqua potabile.

SCONGELAMENTO
Per velocizzare lo scongelamento degli alimenti.

PRIMO UTILIZZO

1. IMPOSTARE L'ORA

Alla prima accensione, è necessario impostare l'ora: sul display lampeggiano l'indicazione "AUTO" e le cifre "0.00".



Per impostare l'ora, premere contemporaneamente i tasti **-** e **+**: Impostare l'ora utilizzando i tasti **+** e **-**.

Note: Per cambiare l'ora in un momento successivo (ad esempio dopo un'interruzione prolungata della corrente elettrica) occorrerà eseguire un reset premendo simultaneamente i tasti **-** e **+**.

2. IMPOSTARE IL SUONO

Dopo aver selezionato i valori desiderati, premere il *tasto di regolazione del tempo*: Sul display viene visualizzato "ton 1".



Per scegliere il suono desiderato, premere il tasto **-**, quindi premere il *tasto di regolazione del tempo* per confermare.

Note: per cambiare le impostazioni in un momento successivo, premere simultaneamente i tasti **-** e **+** e ripetere la procedura sopra descritta.

3. RISCALDARE IL FORNO

Un nuovo forno può rilasciare degli odori dovuti alla lavorazione di fabbrica: questo è normale. Prima di cucinare gli alimenti è dunque raccomandato di riscaldare a vuoto il forno per rimuovere ogni odore.

Rimuovere protezioni di cartone o pellicole trasparenti e togliere gli accessori dal forno. Scaldare il forno a 250 °C per un'ora, utilizzando preferibilmente la funzione "Ventilato". Durante questa procedura il forno deve essere vuoto. Seguire le istruzioni a seguire per impostare correttamente la funzione.

Note: è opportuno ventilare la stanza durante e dopo il primo utilizzo.

USO QUOTIDIANO

1. SELEZIONARE UNA FUNZIONE

Per selezionare una funzione, ruotare la *manopola di selezione* in corrispondenza del simbolo della funzione desiderata.

2. AVVIARE UNA FUNZIONE

Per avviare la funzione selezionata, ruotare la *manopola termostato* per impostare la temperatura desiderata.

Per interrompere una funzione in qualsiasi momento, spegnere il forno, ruotare la *manopola di selezione* e la *manopola del termostato* su **O** e **●**.

3. PRERISCALDAMENTO

Quando si attiva questa funzione, la spia del termostato si accende per segnalare l'inizio della fase di preriscaldamento.

Alla fine del processo, la spia del termostato si spegne per indicare che il forno ha raggiunto la temperatura impostata: a questo punto, inserire gli alimenti e procedere alla cottura.

Note: inserire gli alimenti nel forno prima della fine del preriscaldamento può compromettere i risultati di cottura.

PROGRAMMARE LA COTTURA

Dopo avere selezionato e attivato la funzione è possibile impostare la durata.



Premere per almeno 2 secondi il *tasto di regolazione del tempo*: il simbolo  lampeggia.



Premere nuovamente il *tasto di regolazione del tempo*: sul display vengono visualizzati in sequenza DUR e 0.00 e l'indicazione AUTO lampeggia.

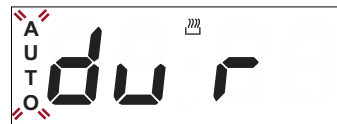

Impostare la durata usando i tasti **+** e **-**. Dopo qualche secondo, sul display viene visualizzata l'ora e l'indicazione AUTO  rimane accesa per confermare l'impostazione.



Note: per visualizzare il tempo di cottura restante, premere il **tasto di regolazione del tempo** per almeno 2 secondi. Per modificarlo (se necessario), premere il tasto una seconda volta e usare i tasti + e - per modificare la durata.

FINE COTTURA

A fine cottura, il simbolo  si spegne, viene emesso un segnale acustico e sul display lampeggia l'indicazione AUTO.



Premere un tasto qualsiasi per disattivare il segnale acustico.

Riportare la manopola funzioni e la *manopola del termostato* su 0 e ●, quindi premere il **tasto di regolazione del tempo** per almeno 2 secondi per spegnere il forno.



IMPOSTAZIONE DEL TIMER

Questa opzione non può essere utilizzata per interrompere o attivare la cottura ma permette di utilizzare il display come timer, sia quando è attiva una funzione che a forno spento.

Per attivare il timer, premere per almeno 2 secondi il **tasto di regolazione del tempo**: sul display lampeggia il simbolo .



























































Impostare la durata usando i tasti + e -: dopo alcuni secondi ha inizio il conto alla rovescia.







Il display mostra l'ora e il simbolo  rimane acceso per confermare che è stato impostato il timer.







































Note: per visualizzare il conto alla rovescia ed eventualmente modificarlo, premere nuovamente il **tasto di regolazione del tempo** per almeno 2 secondi.

TABELLA DI COTTURA

RICETTA	FUNZIONE	PRERISC.	TEMPERATURA (°C)	DURATA (MIN)	LIVELLO E ACCESSORI
Torte a lievitazione		Si	150 - 170	30 - 90	2 
		Si	150 - 170	30 - 90 ***	4 1  
Torte ripiene (cheese cake, strudel, torta di frutta)		Si	160 - 200	35 - 90	2 
		Si	160 - 200	35 - 90 ***	4 2  
Biscotti/Tortine		Si	160 - 180	15 - 35	2 / 3 
		Si	150 - 170	20 - 40 ***	4 2  
Bignè		Si	180 - 200	40 - 60	2 
		Si	170 - 190	35 - 50 ***	4 2  
Meringhe		Si	90	150 - 200	2 
		Si	90	140 - 200 ***	4 2  
Pizza / Focaccia		Si	220 - 250	10 - 25	1 / 2 
		Si	200 - 240	15 - 30 ***	4 2  
Panini 80 g		Si	180 - 200	30 - 45	2 
Pane in cassetta 500 g		Si	180	50 - 70	1 / 2 
Pane		Si	180 - 200	30 - 80 ***	4 2  
Pizze surgelate		Si	250	10 - 20	2 
		Si	250	10 - 20 ***	4 2  
Torte salate (torta di verdura, quiche)		Si	180 - 200	30 - 45	2 
		Si	170 - 190	40 - 60 ***	4 2  
Voulevant / Salatini di pasta sfoglia		Si	190 - 200	20 - 30	2 
		Si	180 - 190	15 - 40 ***	4 2  
Lasagne / Pasta al forno / Cannelloni / Sformati		Si	190 - 200	45 - 65	2 
Agnello / Vitello / Manzo / Maiale 1 kg		Si	190 - 200	80 - 110	2 

FUNZIONI				
	Statico	Grill	Gratin	Ventilato

ACCESSORI					
	Griglia	Teglia o tortiera su griglia	Teglia / Leccarda o pirofila su griglia	Leccarda / Teglia	Leccarda / Teglia con 200 ml d'acqua

RICETTA	FUNZIONE	PRERISC.	TEMPERATURA (°C)	DURATA (MIN)	LIVELLO E ACCESSORI
Arrosto di maiale con cotenna 2kg		Sì	180 - 190	110 - 150	2 
Pollo / Coniglio / Anatra 1 kg		Sì	200 - 230	50 - 100	2 
Tacchino / Oca 3 kg		Sì	180 - 200	150 - 200	2 
Pesce al forno / al cartoccio 0.5 kg (filetti, intero)		Sì	170 - 190	30 - 45	2 
Verdure ripiene (pomodori, zucchine, melanzane)		Sì	180 - 200	50 - 70	2 
Pane tostato		5'	250	2 - 6	5 
Filetti / tranci di pesce		5'	250	15 - 30 *	4 3  
Salsicce / Spiedini / Costine / Hamburger		5'	250	15 - 30 *	5 4  
Pollo arrosto 1-1,3 kg		-	200 - 220	60 - 80 **	3 1  
Roast beef al sangue 1 kg		-	200	35 - 50 **	3 
Cosciotto di agnello / Stinchi		-	200	60 - 90 **	3 
Patate arrosto		-	200 - 220	35 - 55 **	3 
Verdure gratinate		-	200 - 220	25 - 55	3 
Lasagna & Carne		Sì	200	50 - 100 ****	4 1  
Carne & Patate		Sì	190 - 200	45 - 100 ****	4 1  
Pesce & Verdure		Sì	180	30 - 50 ****	4 2  

La durata indicata non comprende la fase di preriscaldamento: si consiglia di inserire gli alimenti nel forno e di impostare la durata della cottura solo al raggiungimento della temperatura desiderata.

* Ruotare il cibo a metà cottura.

** Ruotare il cibo a due terzi di cottura se necessario.

*** Invertire i livelli a metà cottura.

**** La durata è approssimata: le pietanze possono essere tolte dal forno in tempi differenti secondo preferenza. Invertire i livelli a due terzi della cottura (se necessario).

Scaricare le Istruzioni per l'uso dal sito docs.indesit.eu per consultare la tabella delle ricette testate, compilata per gli istituti di valutazione secondo la norma CEI 60350-1.

FUNZIONI	 Statico	 Grill	 Gratin	 Ventilato
ACCESSORI	 Griglia	 Teglia o tortiera su griglia	 Teglia / Leccarda o pirofila su griglia	 Leccarda / Teglia
				 Leccarda / Teglia con 200 ml d'acqua

MANUTENZIONE E PULIZIA



Per maggiori informazioni, scaricare le istruzioni per l'uso da docs.indesit.eu

Non usare pulitrici a getto di vapore.

Utilizzare guanti protettivi durante tutte le operazioni.

Eseguire le operazioni indicate a forno freddo.

Scollegare l'apparecchio dalla rete elettrica.

Non usare pagliette metalliche, panni abrasivi e detersivi abrasivi o corrosivi che possano danneggiare le superfici.

SUPERFICI ESTERNE

Pulire le superfici con un panno in microfibra umido. Se molto sporche, aggiungere qualche goccia di detersivo neutro. Asciugare con un panno asciutto. Non usare detersivi corrosivi o abrasivi. Se inavvertitamente uno di questi prodotti dovesse venire a contatto con le superfici, pulire subito con un panno in microfibra umido.

SUPERFICI INTERNE

• Dopo ogni uso, lasciare raffreddare il forno e pulirlo preferibilmente quando è ancora tiepido per rimuovere incrostazioni e macchie dovute a residui di cibo; per asciugare la condensa dovuta alla cottura di alimenti con un elevato contenuto di acqua, usare a forno freddo un panno o una spugna.

- Per facilitare la pulizia dei vetri è possibile rimuovere e smontare facilmente la porta .
- Pulire i vetri della porta con detersivi liquidi specifici.
- La resistenza superiore del grill può essere abbassata per pulire la parete superiore del forno: estrarre la resistenza dalla sede e abbassarla. Per reinserire la resistenza in posizione, sollevarla, tirarla leggermente verso di sé e controllare che il supporto sia posizionato correttamente.

ACCESSORI

Mettere a bagno gli accessori con detersivo per piatti dopo l'uso, maneggiandoli con guanti da forno, se ancora caldi. I residui di cibo possono essere rimossi con una spazzola per piatti o con una spugna.

TOGLIERE E RIMONTARE LA PORTA

1. Per rimuovere la porta, aprirla completamente e abbassare i fermi fino alla posizione di sblocco.

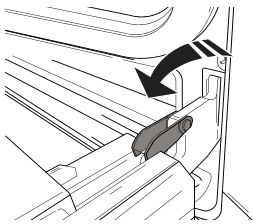

2. Chiudere la porta fino a quando è possibile. Prendere saldamente la porta con entrambe le mani, evitando di tenerla per la maniglia. Per estrarla facilmente, continuare a chiuderla e contemporaneamente tirarla verso l'alto (a) finché non esce dalle sedi (b).

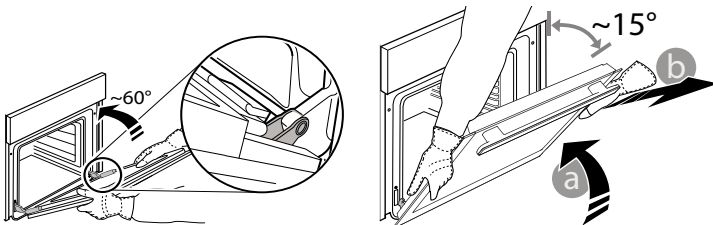

Togliere la porta e appoggiarla su un piano morbido.

3. Per rimontare la porta, avvicinarla al forno allineando i ganci delle cerniere alle proprie sedi e ancorare la parte superiore agli alloggiamenti.

4. Abbassare la porta e poi aprirla completamente. Abbassare i fermi nella posizione originale: fare attenzione che siano completamente abbassati.

5. Provare a chiudere la porta, verificando che sia allineata al pannello di controllo. Se non lo fosse, ripetere tutte le operazioni.

CLICK & CLEAN - PULIRE IL VETRO

1. Dopo aver smontato la porta e averla appoggiata su un ripiano morbido con la maniglia verso il basso, premere contemporaneamente le due clip di fissaggio ed estrarre il profilo superiore della porta tirandolo verso di sé.

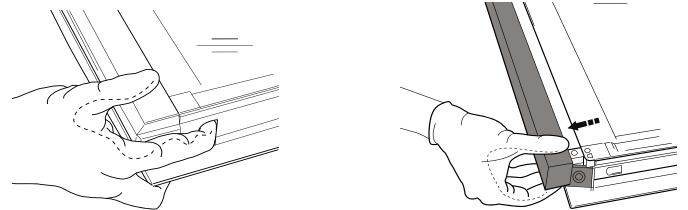

2. Sollevare e prendere saldamente il vetro interno con due mani, rimuoverlo e appoggiarlo su un piano morbido prima di eseguire la pulizia.

3. Per riposizionare correttamente il vetro interno, fare attenzione che la "R" sia leggibile nell'angolo destro e che la superficie lucida (non stampata) sia rivolta verso l'alto. Inserire dapprima il lato lungo del vetro indicato dalla "R" nelle sedi di sostegno, quindi abbassarlo in posizione.

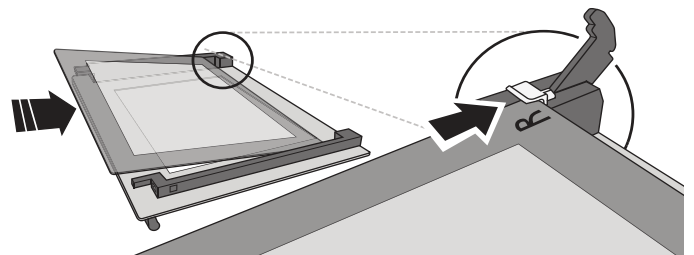

4. Rimontare il profilo superiore: un clic indica il corretto posizionamento. Verificare che la tenuta sia salda prima di rimontare la porta.



Problema	Possibile causa	Soluzione
Il forno non funziona.	Interruzione di corrente elettrica. Disconnessione dalla rete principale.	Verificare che ci sia tensione in rete e che il forno sia collegato all'alimentazione elettrica. Spegnere e riaccendere il forno e verificare se l'inconveniente persiste.

CONSIGLI UTILI



Per maggiori informazioni, scaricare le istruzioni per l'uso da docs.indesit.eu

COME LEGGERE LA TABELLA DI COTTURA

La tabella indica la funzione, gli accessori e il livello migliore da utilizzare per cuocere svariati tipi di cibo. I tempi di cottura si riferiscono all'introduzione del cibo nel forno, escluso il preriscaldamento (dove richiesto). Le temperature e i tempi di cottura sono indicativi e dipendono dalla quantità di cibo e dal tipo di accessori. Utilizzare inizialmente i valori più bassi consigliati e, se il risultato della cottura non è quello desiderato, passare a quelli più alti. Si consiglia di utilizzare gli accessori in dotazione e tortiere o teglie possibilmente in metallo scuro. È possibile utilizzare anche pentole e accessori in pyrex o in ceramica, i tempi di cottura si allungheranno leggermente.

CUCINARE DIFFERENTI ALIMENTI CONTEMPORANEAMENTE

Utilizzando la funzione "Ventilato", è possibile cuocere contemporaneamente cibi diversi (ad esempio: pesce e verdure), su ripiani diversi. Invertire i livelli a due terzi della cottura (se necessario). Estrarre i cibi che richiedono tempi di cottura inferiori e lasciare continuare la cottura per quelli con tempi più lunghi.

DATI TECNICI

La scheda del prodotto comprensiva dei dati energetici di questo forno può essere scaricata dal sito internet docs.indesit.eu

COME OTTENERE LE ISTRUZIONI PER L'USO

> Scaricare le Istruzioni per l'uso dal sito web docs.indesit.eu (è possibile utilizzare questo codice QR) specificando il codice prodotto.



> In alternativa, contattare il Servizio di Assistenza Clienti.

CONTATTARE IL SERVIZIO ASSISTENZA CLIENTI

I contatti possono essere trovati sul manuale di garanzia. Quando si contatta il Servizio Assistenza fornire i codici presenti sulla targhetta matricola del prodotto.

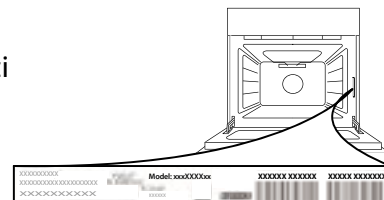

يمكنك تنزيل تعليمات السلامة ودليل الاستخدام والعناية من خلال زيارة موقعنا على docs.indesit.eu واتباع التعليمات بظهر الكتاب.



نشرك لشراء أحد منتجات INDESIT للحصول على مزيد من المساعدة والدعم الشامل، يرجى تسجيل منتجك على الموقع www.indesit.com/register



قبل استخدام الجهاز، احرص على قراءة دليل الصحة والأمان بعناية.



شرح المنتج

1. لوحة التحكم
2. المروحة
3. مصباح
4. مجاري الرف (المستوى مميز على جدار حيز الطهي)
5. الباب
6. عنصر التسخين العلوي / الشواية
7. لوحة التمييز (لا تخلصها)
8. عنصر التسخين السفلي (غير مرئي)

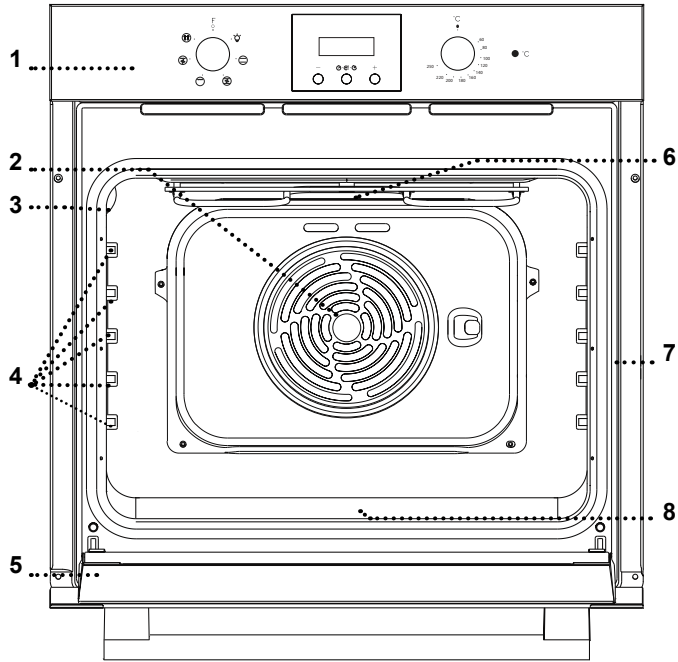

لوحة التحكم

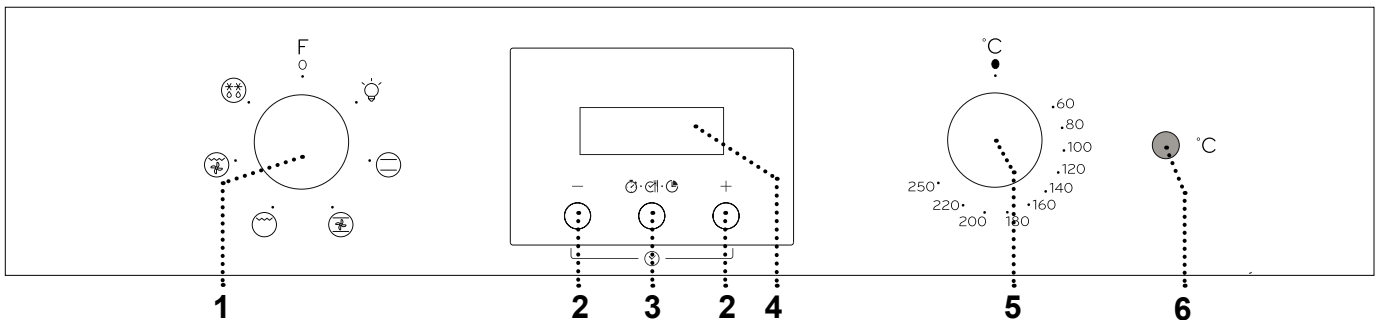

6. لمبة دايمود الثرموستات / الإحماء
تضيء أثناء عملية التسخين. تنطفئ بمجرد الوصول إلى درجة الحرارة المرغوبة.

3. زر الوقت
لاختيار الإعدادات المختلفة: مدة الطهي، وقت انتهاء الطهي، الميقاتي.

4. وحدة العرض

5. مفتاح ثرموستات
أدره لاختيار درجة الحرارة المطلوبة.

1. مفتاح الاختيار
لتشغيل الفرن عن طريق اختيار وظيفة. أدر إلى الوضع 0 لإيقاف تشغيل الفرن.

2. الزر +/-
لتقليل أو زيادة القيمة المعروضة على الشاشة.

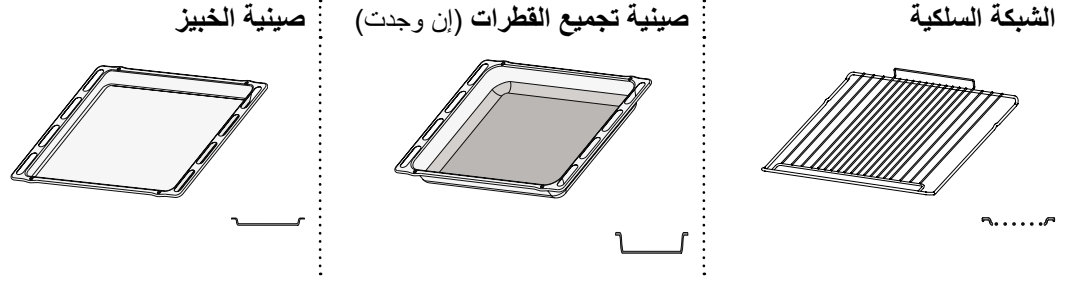

قد يختلف عدد ونوع الكماليات تبعاً للطراز الذي اشتريته. يمكن شراء الكماليات الأخرى بشكل منفصل من خدمة ما بعد البيع.

استخدام الكماليات

• أدخل الشبكة السلكية في المستوى المرغوب عن طريق مسكها في وضع مائل قليلاً لأعلى ثم ضع الجانب الخلفي البارز (موجهاً لأعلى) في الأسفل أولاً. ثم قم بتحريكها على امتداد مجاري الرف إلى أبعد قدر ممكن.

بالنسبة للكماليات الأخرى مثل صينية الخبز فيتم إدخالها أفقياً بجعلها تنزلق على امتداد المجاري الدليلية للرف.

يمكن إزالة المجاري الدليلية للرف لتسهيل تنظيف الفرن: اسحبها لخلعها من مواضع تثبيتها.

<p>GRATIN </p> <p>لشواء قطع لحم الروست الكبيرة (الأفخاذ، الروز بيف، الدجاج). نوصي باستخدام صينية الخبز لتجميع مرق الطهي: ضع الصينية على أي مستوى أسفل الشبكة السلكية وأضف 200 مل من ماء الشرب.</p>	<p>الإيقاف </p> <p>إيقاف الفرن.</p>
<p>إذابة التجمد </p> <p>لإذابة التجمد عن الطعام بشكل أسرع.</p>	<p>الإضاءة </p> <p>إضاءة المصباح في الحيز.</p>
	<p>تقليدي </p> <p>لطهي أي نوع من الأطباق على رف واحد فقط. يفضل استخدام المستوى الثاني.</p>
	<p>الخبز بالتوزيع الحراري </p> <p>لإعداد الكيك ذي الحشو السائل على رف واحد. يمكن استخدام هذه الوظيفة أيضاً للطهي على رفين. قم بتبديل أوضاع الأطباق لطهي الطعام بدرجة متساوية.</p>
	<p>GRILL </p> <p>لشواء شرائح اللحم، الكباب والسجق وطهي جراتان الخضروات والخبز المحمص. عند شواء اللحم، نوصي باستخدام صينية الخبز لتجميع مرق الطهي: ضع الصينية على أي مستوى أسفل الشبكة السلكية وأضف 200 مل من ماء الشرب.</p>

1. ضبط الوقت

يلزم ضبط الوقت عند تشغيل الجهاز لأول مرة: تومض "AUTO" (أوتوماتيكي) و "0.00" في وحدة العرض.



لضبط وقت اليوم، اضغط على الأزرار - و + في نفس الوقت: اضبط وقت اليوم باستخدام الأزرار + و -.

يرجى ملاحظة: لتغيير وقت اليوم بعد ذلك (مثلا في حالة عودة التيار بعد انقطاعه لفترة طويلة) ستحتاج إلى إعادة ضبط الوقت بالضغط على الأزرار - و + في نفس الوقت.

2. ضبط الصوت

بعد اختيار قيمة الوقت المرغوبة، اضغط على زر الوقت: فيظهر في الشاشة "1 ton".

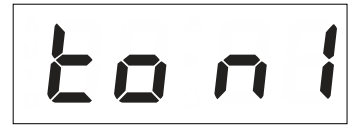

لاختيار الصوت المرغوب اضغط على الزر - ثم اضغط على زر الوقت للتأكيد.

يرجى ملاحظة: لتغيير الإعدادات بعد ذلك اضغط على الزرين - و + في نفس الوقت وكرر الخطوات المذكورة أعلاه.

3. تسخين الفرن

قد ينبعث من الفرن الجديد روائح كريهة ناتجة عن آثار التصنيع: وهذا أمر طبيعي تماما.

قبل البدء في طهي الطعام ننصح بتسخين الفرن وهو خال للتخلص من أية روائح غير مستحبة.

انزع قطع الحماية المصنوعة من الورق المقوى أو الرقائق الشفافة من الفرن وأخرج الكماليات من الداخل.

قم بتسخين الفرن حتى 250 °م لمدة ساعة تقريبا، ومن المفضل استخدام وظيفة "الخبيز بالتوزيع الحراري". يجب أن يكون الفرن فارغا خلال هذه المدة.

اتبع التعليمات لإعداد الوظيفة بشكل صحيح.

يرجى ملاحظة أنه: من الأفضل تهوية الغرفة بعد استخدام الجهاز لأول مرة.

الاستخدام اليومي

1. اختيار وظيفة

لاختيار وظيفة ما، أدر مفتاح الاختيار إلى الرمز الخاص بالوظيفة المرغوبة.

2. تفعيل وظيفة

لبدء تشغيل الوظيفة التي تم اختيارها، أدر مفتاح الثرموستات لضبط درجة الحرارة المرغوبة.

لإيقاف الوظيفة في أي وقت أوقف الفرن وأدر مفتاح الاختيار و مفتاح الثرموستات إلى 0 و ●.

3. الإحماء

بمجرد تفعيل الوظيفة تضيء لمبة دايمود الثرموستات للإشارة أن فترة الإحماء قد بدأت.

في نهاية هذه العملية تنطفئ لمبة دايمود الثرموستات للإشارة إلى وصول الفرن إلى درجة الحرارة المضبوطة: في هذا الوقت ضع الطعام في الداخل وابدأ الطهي.

يرجى ملاحظة أنه: وضع الطعام قبل الانتهاء من إحماء الفرن، قد يترتب عنه آثار سلبية على نتائج الطهي النهائية.

. برمجة الطهي

بعد اختيار الوظيفة وتفعيلها يمكن ضبط المدة.



اضغط لمدة ثانيتين على زر الوقت: يومض الرمز (⌚).



اضغط على زر الوقت مرة أخرى: يظهر في وحدة العرض الرمز DUR (المدة) و 0.00 بالتتابع بينما يومض الرمز AUTO (أوتوماتيكي).

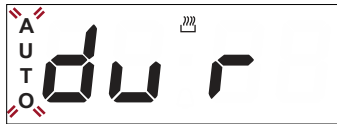

اضبط المدة باستخدام الأزرار + و - . بعد ثوان قليلة يظهر في وحدة العرض وقت اليوم، بينما يظل الرمز AUTO مضبئا، مما يؤكد الإعداد.

A
U
T
O 12:30



يرجى ملاحظة أنه: لاستعراض مدة الطهي المتبقية اضغط على زر الوقت لمدة ثانيتين على الأقل.
لتغيير ذلك، عند الضرورة، اضغط مرة أخرى باستخدام الأزرار + و - لتعديل المدة.

انتهاء الطهي
في نهاية الطهي ينطفئ الرمز  ويصدر الإنذار ويومض الرمز AUTO (أوتوماتيكي) في وحدة العرض.

A
U
T
O 13:20

اضغط على الزر لإيقاف فعالية الإنذار.

أعد مفتاح الوظيفة و مفتاح إثيرموستات إلى O و ●، ثم اضغط على زر الوقت لمدة ثانيتين على الأقل لإيقاف الفرن.

 ضبط الميقاتي
لا تقوم هذه الوظيفة الاختيارية بإيقاف أو تفعيل الطهي وإنما تسمح باستخدام وحدة العرض كميقاتي، سواء خلال تفعيل وظيفة ما أو عند إيقاف الفرن.
لتفعيل الميقاتي اضغط زر الوقت لمدة ثانيتين على الأقل: يضيء الرمز  في وحدة العرض.

0:00

استخدم الأزرار + و - لضبط المدة المرغوبة: ويبدأ العد التنازلي بعد ثوان قليلة.





12:30

يظهر بالشاشة وقت اليوم ويظل الرمز  مضيئاً، مما لتأكيد أنه قد تم ضبط الميقاتي.

يرجى ملاحظة: لاستعراض العد التنازلي وتغييره عند اللزوم اضغط مجدداً على زر الوقت لمدة ثانيتين.

المستوى والكماليات	المدة (دقيقة)	درجة الحرارة (م°)	الإجماع	الوظيفة	الوصفة
2 	90 - 30	170 - 150	نعم		كيك مخمر
1 4 	*** 90 - 30	170 - 150	نعم		
2 	90 - 35	200 - 160	نعم		كيك محشو (تشيز كيك، فطيرة محشوة، فطيرة فواكه)
2 4 	*** 90 - 35	200 - 160	نعم		
3 / 2 	35 - 15	180 - 160	نعم		البسكويت/تارت الفواكه الصغير
2 4 	*** 40 - 20	170 - 150	نعم		
2 	60 - 40	200 - 180	نعم		معجنات الشو
2 4 	*** 50 - 35	190 - 170	نعم		
2 	200 - 150	90	نعم		الميرننجز
2 4 	*** 200 - 140	90	نعم		
2 / 1 	25 - 10	250 - 220	نعم		بيتزا/خبز الفوكاشيا
2 4 	*** 30 - 15	240 - 200	نعم		
2 	45 - 30	200 - 180	نعم		رغيف خبز صغير 80 جم
2 / 1 	70 - 50	180	نعم		رغيف خبز 500 جم
2 4 	*** 80 - 30	200 - 180	نعم		الخبز
2 	20 - 10	250	نعم		البيتزا المجمدة
2 4 	*** 20 - 10	250	نعم		
2 	45 - 30	200 - 180	نعم		كعك متبل (فطيرة الخضروات، فطيرة كيش)
2 4 	*** 60 - 40	190 - 170	نعم		
2 	30 - 20	200 - 190	نعم		مخبوزات فول-أو-فان/باف باستري
2 4 	*** 40 - 15	190 - 180	نعم		
2 	65 - 45	200 - 190	نعم		لازانيا / معكرونة فرن / كانلوني / كعكة الفواكه
2 	110 - 80	200 - 190	نعم		لحم ضأن/لحم بتلو / لحم بقري/لحم دسم 1 كجم

				الوظائف
الخبز بالتوزيع الحراري	Gratin	Grill	تقليدي	

					الكماليات
صينية تجميع الفطرات / صينية الخبز مع إضافة 200 مل من الماء	صينية تجميع الفطرات/صينية الخبز	صينية الخبز/صينية تجميع الفطرات أو طبق الخبز على الشبكة السلكية	طبق الخبز أو صينية الكيك على الشبكة السلكية	الشبكة السلكية	

المستوى والكماليات	المدة (دقيقة)	درجة الحرارة (م°)	الإحماء	الوظيفة	الوصفة
2	150 - 110	190 - 180	نعم		لحم دسم محمر بقشرة 2 كجم
2	100 - 50	230 - 200	نعم		دجاج/أرانب/بط 1 كجم
2	200 - 150	200 - 180	نعم		ديك رومي/أوز 3 كجم
2	45 - 30	190 - 170	نعم		سمك مشوي/مطهو وهو مغلف بورق الزبدة 5.0 كجم (فيليه، سمكة كاملة)
2	70 - 50	200 - 180	نعم		خضروات محشوة (طماطم، كوسة، بادنجان)
5	6 - 2	250	'5		خبز محمص
3 4	* 30 - 15	250	'5		سمك فيليه/شرائح
4 5	* 30 - 15	250	'5		السجق/الكباب/ قطع لحم الضلوع "الريش"/شطائر البيف برجر
1 3	** 80 - 60	220 - 200	-		دجاجة مشوية 1-3.1 كجم
3	** 50 - 35	200	-		لحم بقري نيء 1 كجم
3	** 90 - 60	200	-		فخذ ضأن/زند
3	** 55 - 35	220 - 200	-		بطاطس محمرة
3	55 - 25	220 - 200	-		جراتان الخضروات
1 4	**** 100 - 50	200	نعم		اللازانيا واللحم
1 4	**** 100 - 45	200 - 190	نعم		اللحم والبطاطس
2 4	**** 50 - 30	180	نعم		الأسماك والخضروات

لا يتضمن الوقت الموضح فترة الإحماء: ننصح بوضع الطعام في الفرن وضبط زمن الطهي بعد الوصول إلى درجة الحرارة المطلوبة.

قم بتنزيل دليل الاستخدام والعناية من الموقع docs.indesit.eu للاطلاع على جدول الوصفات المختبرة المتطابقة مع هيئات التوثيق وفقا للمواصفة IEC 60350-1.

* اقلب الطعام في منتصف دورة الطهي.
** اقلب الطعام بعد انقضاء ثلثي مدة الطهي (عند اللزوم).
*** قم بتبديل المستويات في منتصف عملية الطهي.
**** طول المدة المقدر: يمكن إزالة الأطباق من الفرن في أوقات مختلفة حسب التفضيل الشخصي. التبديل الرفوف اقلب الطعام بعد انقضاء ثلثي مدة الطهي عند اللزوم.

الوظائف	الكماليات
 الخبيز بالتوزيع الحراري	 صينية تجمع القطرات / صينية الخبيز مع إضافة 200 مل من الماء
 Gratin	 صينية تجمع القطرات/صينية الخبيز
 Grill	 صينية الخبيز/صينية تجمع القطرات أو طبق الخبيز على الشبكة السلكية
 تقليدي	 طبق الخبيز أو صينية الكيك على الشبكة السلكية
 تقليدي	 الشبكة السلكية

لا تستخدم ألياف سلكية، مساحيق كاشطة أو منظفات مزيلة/أكالة، لأنها قد تعرض أسطح الجهاز للضرر.

وقم بإجراء الأعمال المرغوبة بينما الفرن بارد.
افصل الجهاز عن مصدر الإمداد بالكهرباء.

لا تستخدم أجهزة التنظيف بالبخار.
احرص على استخدام القفازات الواقية في جميع الأعمال.

• يمكن خلع الباب وإعادة تركيبه بسهولة لتنظيف الزجاج بأريحية www.

• قم بتنظيف زجاج الباب باستخدام منظف سائل ملائم.
• كما يمكن إنزال عنصر التسخين العلوي للشواية لغرض تنظيف الغطاء العلوي للفرن: أخرج عنصر التسخين من موضع تثبيته ثم قم بخفضه. لإعادة تركيب عنصر التسخين في موضعه ارفعه واجذبه باتجاهك بعض الشيء وتأكد أن اللسان مستقرا في موضع التثبيت المناسب.

الكماليات

انقع الكماليات في منظف غسيل أطباق فور الاستخدام، وتعامل معها بقفازات الفرن إذا كانت لا تزال ساخنة. يمكن إزالة بقايا الأطعمة بسهولة باستخدام فرشاة الغسيل أو إسفنجية.

الأسطح الخارجية

قم بتنظيف الأسطح بقطعة قماش دقيقة الألياف رطبة. إذا كانت الأسطح شديدة الاتساخ، فأضف بضع قطرات من منظف محايد إلى الماء. وجففها في النهاية باستخدام قطعة قماش جافة.
لا تستخدم منظفات أكالة أو كاشطة. إذا حدث أن تلامس أي من هذه المنتجات مع أسطح الجهاز سهواً، قم بتنظيفها على الفور بقطعة قماش دقيقة الألياف ورطبة.

الأسطح الداخلية

• بعد كل استخدام، اترك الفرن يبرد ثم قم بتنظيفه، يُفضل التنظيف وهو دافئ، لإزالة أية رواسب أو بقع ناتجة عن بقايا الأطعمة. ولتجفيف أي تكاثف للماء تم تكوينه نتيجة طهي الأطعمة باستخدام قدر كبير من الماء، اترك الفرن حتى يبرد تماماً ثم قم بمسحه بقطعة قماش أو إسفنجية.

انقر ونظف - تنظيف الزجاج

1. بعد خلع الباب ووضعه على سطح ناعم بينما المقبض موجها لأسفل، اضغط في نفس الوقت على مشبكي التثبيت واخلع الحافة العلوية من الباب من خلال سحبها في اتجاهك.

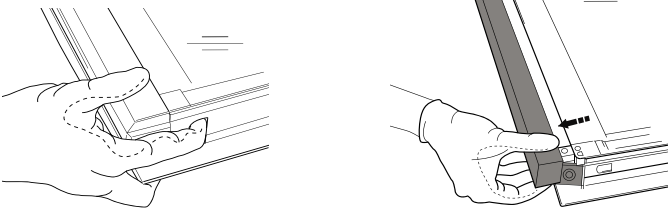

2. ارفع الزجاج الداخلي وأحكم مسكه بكلتا يديك، ثم اخلعه وضعه على سطح ناعم قبل تنظيفه.

3. لإعادة تركيب الزجاج الداخلي بشكل صحيح، تحقق من إمكانية مشاهدة الحرف "R" في الركن الأيسر. أدخل أولا الجانب الطويل من الزجاج المميز بالحرف "R" في ركائز الدعم (a) ثم أنزله في موضعه.

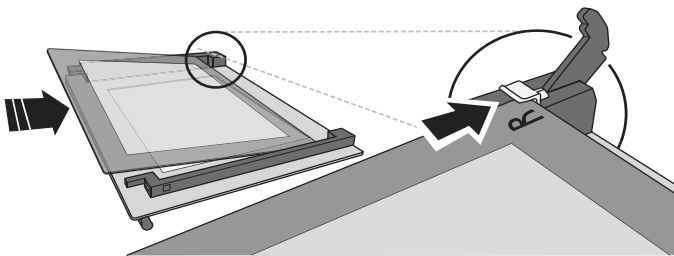

4. أعد تركيب الحافة العلوية: يشير صوت كليك إلى الوضع الصحيح. تأكد من تأمين إطار الإحكام قبل إعادة تركيب الباب.

خلع الباب وإعادة تركيبه

1. لخلع الباب، افتحه بالكامل ثم أنزل السقاطات إلى أن تصبح في وضع تحرير القفل.

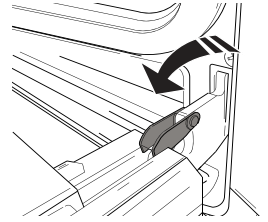

2. أغلق الباب قدر استطاعتك.
أحكم مسك الباب بكلتا يديك - لا تحمله من المقبض.
بعد ذلك ما عليك سوى خلع الباب بمواصلة غلقه مع سحبه لأعلى في نفس الوقت (a) حتى يتحرر من موضع تثبيته (b).

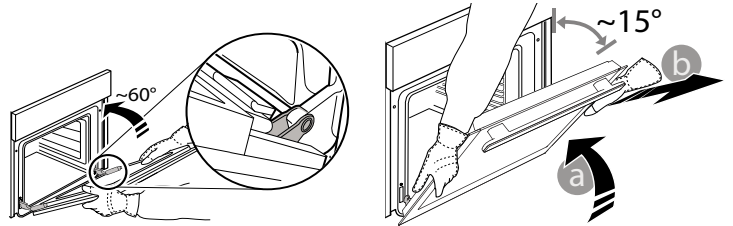

ضع الباب على جانب واحد واجعله مستقر على سطح ناعم.

3. أعد تركيب الباب بتحريكه نحو الفرن، وقم بمحاذاة خطافات المفصلات مع موضع التثبيت ثم قم بتأمين الجزء العلوي في موضع التثبيت.

4. قم بإنزال الباب ثم افتحه بالكامل.
قم بإنزال السقاطات في موضعها الأصلي: وتأكد من إنزالها للأسفل تماماً.

5. حاول غلق الباب وافحص للتأكد من محاذاته مع لوحة التحكم. وإن لم يكن الأمر كذلك، أعد تنفيذ الخطوات أعلاه.

المشكلة	السبب المحتمل	الحل
الفرن لا يعمل.	انقطاع التيار الكهربائي. الفصل من الشبكة الكهربائية.	تحقق من وجود طاقة كهربائية بالشبكة الكهربائية ومن توصيل الفرن بمصدر الكهرباء. أوقف الفرن، ثم أعد تشغيله للتحقق مما إذا كان العطل لا يزال قائماً.

طهي أطعمة مختلفة في الوقت نفسه
تتيح وظيفة "الخبيز بالتوزيع الحراري" طهي أنواع متعددة من الأطعمة (مثل السمك والخضروات) وذلك على أرفف مختلفة في نفس الوقت. التبديل الرفوف اقلب الطعام بعد انقضاء ثلثي مدة الطهي عند اللزوم. أخرج الطعام الذي يتطلب وقت طهي أقل وأترك الطعام الذي يتطلب وقت طهي أطول في الفرن.

كيفية قراءة جدول الطهي
يورد الجدول أفضل الوظائف والكماليات والمستويات للاستخدام في طهي الأنواع المختلفة من الطعام. وتبدأ أوقات الطهي من لحظة وضع الطعام في الفرن، وذلك باستثناء الإحماء (عند الحاجة). درجات حرارة وأوقات الطهي هو مجرد قيم تقريبية، كما أنها تعتمد على مقدار الطعام ونوع الكماليات المستخدمة. ابدأ باستخدام أقل إعدادات موصى بها، وإذا لم يتم طهي الطعام بشكل كافٍ، فانتقل إلى إعدادات أعلى. استخدم الكماليات المرفقة، ويفضل استخدام صواني الكيك وصواني الخبيز المعدنية داكنة اللون. ويمكنك أيضاً استخدام الأواني والكماليات المصنوعة من البيركس والفخار، ولكن تذكر أن أوقات الطهي ستطول بعض الشيء.

الاتصال بخدمة ما بعد البيع لدينا

يمكنك الاطلاع على تفاصيل الاتصال بنا في كتيب الضمان. يرجى عند الاتصال بخدمة ما بعد البيع ذكر الأكواد المذكورة على لوحة تمييز المنتج.

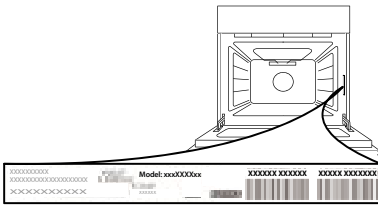

كتيب المنتج

www يمكنك تنزيل كتيب المنتج الخاص بهذا الجهاز شاملاً معدلات كفاءة استهلاك الطاقة عبر موقعنا docs.indesit.eu

كيفية الحصول على دليل الاستخدام والعناية

< www قم بتنزيل دليل الاستخدام والعناية من موقعنا على الإنترنت docs.indesit.eu (يمكنك استخدام رمز الاستجابة السريع QR هذا)، مع تحديد الرمز التجاري للمنتج.



< كبديل، اتصل بخدمة ما بعد البيع لدينا.

DAILY REFERENCE GUIDE



THANK YOU FOR PURCHASING AN INDESIT PRODUCT

To receive more comprehensive help and support, please register your product at www.indesit.com/register



You can download the Safety Instructions and the Use and Care Guide by visiting our website docs.indesit.eu and following the instructions on the back of this booklet.



Before using the appliance carefully read the Health and Safety guide.

PRODUCT DESCRIPTION

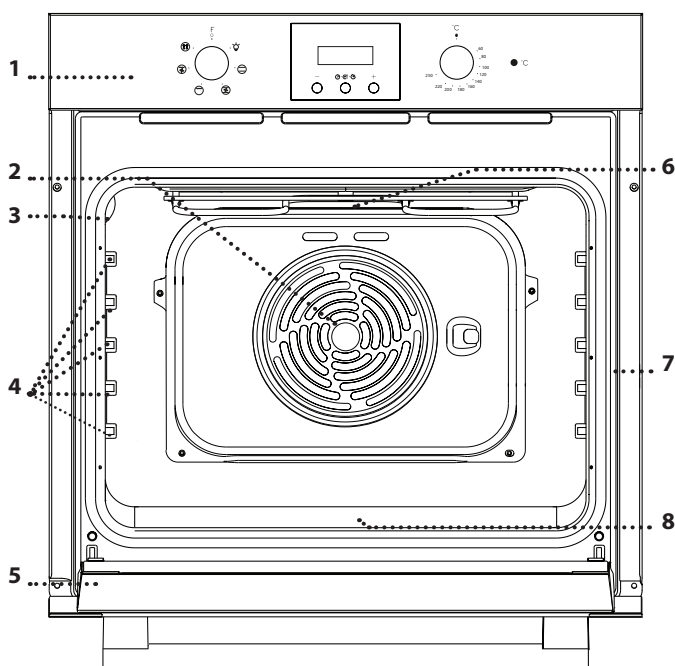

1. Control panel
2. Fan
3. Lamp
4. Shelf guides
(the level is indicated on the wall of the cooking compartment)
5. Door
6. Upper heating element/grill
7. Identification plate
(do not remove)
8. Bottom heating element
(non-visible)

CONTROL PANEL

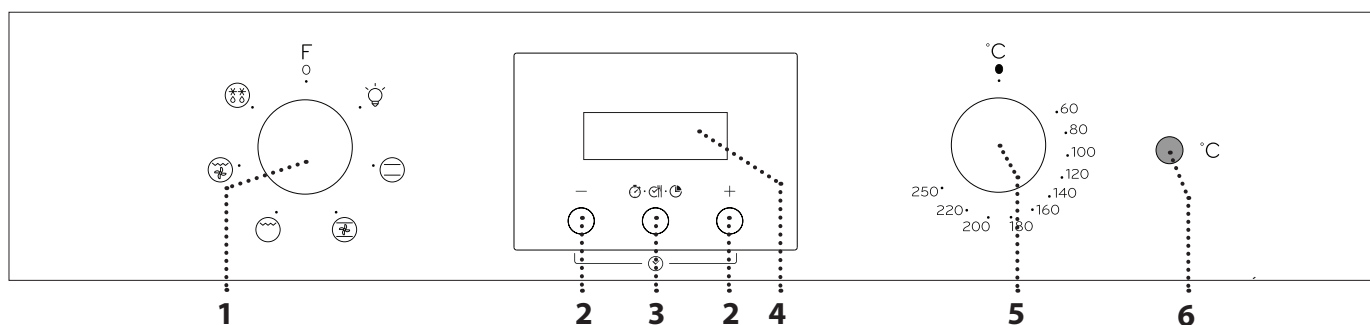

1. SELECTION KNOB

For switching the oven on by selecting a function. Turn to the O position to switch the oven off.

2. +/- BUTTON

To decrease or increase the value shown on the display.

3. TIME BUTTON

For selecting the various settings: duration, cooking end time, timer.

4. DISPLAY

5. THERMOSTAT KNOB

Turn to select the temperature you require.

6. LED THERMOSTAT/ PREHEATING

Switches on during the heating process. Switches off once the desired temperature is reached.

WIRE SHELF

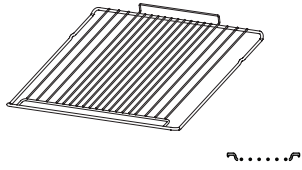

DRIP TRAY (IF PRESENT)

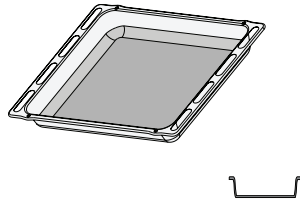

BAKING TRAY

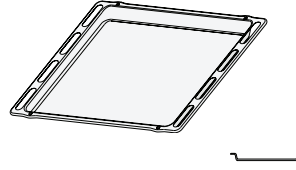

The number and the type of accessories may vary depending on which model is purchased. Other accessories can be purchased separately from the After-sales Service.

USING THE ACCESSORIES

• Insert the wire shelf onto the level you require by holding it tilted slightly upwards and resting the raised rear side (pointing upwards) down first. Then slide it horizontally along the shelf guide as far as possible.

The other accessories, such as the baking tray, are inserted horizontally by sliding them along the shelf guides.

The shelf guides can be removed to facilitate the oven cleaning: pull them to remove from their seats.

FUNCTIONS

OFF
For switching off the oven.

LIGHT
For switching on the light in the compartment.

CONVENTIONAL
For cooking any kind of dish on one shelf only. It is best to use the 2nd shelf.

CONVECTION BAKE
For baking cakes with juicy fillings on a single shelf. This function can also be used for cooking on two shelves. Switch the position of the dishes to cook food more evenly.

GRILL
For grilling steaks, kebabs and sausages, cooking vegetables au gratin or toasting bread. When grilling meat, we recommend using a Baking tray to collect the cooking juices: position the pan on any of the levels below the wire shelf and add 200 ml of drinking water.

GRATIN
For roasting large joints of meat (legs, roast beef, chicken). We recommend using a Baking tray to collect the cooking juices: position the pan on any of the levels below the wire shelf and add 200 ml of drinking water.

DEFROSTING
For defrosting food more quickly.

USING THE APPLIANCE FOR THE FIRST TIME

1. SETTING THE TIME

You will need to set the time when you switch on the appliance for the first time: "AUTO" and "0.00" flash on the display.



To set the time of day, press buttons — and + at the same time: Set the time of day using the + and — buttons.

Please note: To change the time of the day afterwards (for example following lengthy power outages) you will need to reset the time by pressing buttons — and + at the same time.

2. SETTING THE TONE

Having selected the desired time value, press the *time button*: The display shows "ton 1".



To select the desired tone, press button —, then press the *time button* to confirm.

Please note: To change settings afterwards, press buttons — and + at the same time and repeat the operations above.

3. HEAT THE OVEN

A new oven may release odours that have been left behind during manufacturing: this is completely normal.

Before starting to cook food, we therefore recommend heating the oven with it empty in order to remove any possible odours.

Remove any protective cardboard or transparent film from the oven and remove any accessories from inside it.

Heat the oven to 250 °C for about one hour, preferably using the "Convection Bake" function. The oven must be empty during this time.

Follow the instructions for setting the function correctly.

Please note: It is advisable to air the room after using the appliance for the first time.

DAILY USE

1. SELECT A FUNCTION

To select a function, turn the *selection knob* to the symbol for the function you require.

2. ACTIVATE A FUNCTION

To start the function you have selected, turn the *thermostat knob* to set the temperature you require.

To interrupt the function at any time, switch off the oven, turn the *selection knob* and the *thermostat knob* to 0 and ●.

3. PREHEATING

Once the function has been activated, the LED thermostat will switch on signalling that the preheating process has begun.

At the end of this process, the LED thermostat switches off indicating that the oven has reached the set temperature: at this point, place the food inside and proceed with cooking.

Please note: Placing the food in the oven before preheating has finished may have an adverse effect on the final cooking result.

. PROGRAMMING COOKING

After selecting and activating the function, it is possible to set the duration.



Press for at least 2 seconds the *time button*: the symbol flashes.



Press the *time button* again: the display shows DUR and 0.00 in sequence while AUTO flashes.

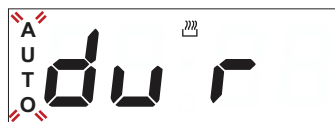

Set the duration using the buttons + and —. After a few seconds, the display shows the time of the day while AUTO  remain lit, confirming the setting.



Please note: To view the remaining cooking duration press the **time button** for at least 2 seconds.
To change it, if necessary, press it again a second time, using + and - buttons to modify the duration.

COOKING END

At the end of cooking, the symbol  switches off, an alarm sounds while AUTO flashes on the display.



Press any button to deactivate the alarm.

Return the function knob and *thermostat knob* to 0 and ●, then press the **time button** for at least 2 seconds to switch off the oven.



SETTING THE TIMER

This option does not interrupt or activate cooking but allows you to use the display as a timer, both while a function is active and when the oven is off.

To activate the timer, press the **time button** for at least 2 seconds: the  symbol flashes on the display.



























































Use the + and - buttons to set the desired duration: the countdown begins after a few seconds.







The display shows the time of the day and the  remains lit, confirming the timer has been set.

Please note: To view the countdown and change it if necessary, press again the **time button** for at least 2 seconds.

COOKING TABLE

RECIPE	FUNCTION	PREHEAT	TEMPERATURE (°C)	DURATION (MIN)	LEVEL AND ACCESSORIES
Leavened cakes		Yes	150 - 170	30 - 90	2 
		Yes	150 - 170	30 - 90 ***	4 1  
Filled cake (cheese cake, strudel, fruit pie)		Yes	160 - 200	35 - 90	2 
		Yes	160 - 200	35 - 90 ***	4 2  
Biscuits/tartlets		Yes	160 - 180	15 - 35	2 / 3 
		Yes	150 - 170	20 - 40 ***	4 2  
Choux buns		Yes	180 - 200	40 - 60	2 
		Yes	170 - 190	35 - 50 ***	4 2  
Meringues		Yes	90	150 - 200	2 
		Yes	90	140 - 200 ***	4 2  
Pizza/Focaccia		Yes	220 - 250	10 - 25	1 / 2 
		Yes	200 - 240	15 - 30 ***	4 2  
Small bread 80 g		Yes	180 - 200	30 - 45	2 
Bread loaf 500 g		Yes	180	50 - 70	1 / 2 
Bread		Yes	180 - 200	30 - 80 ***	4 2  
Frozen pizzas		Yes	250	10 - 20	2 
		Yes	250	10 - 20 ***	4 2  
Salty cakes (vegetable pie, quiche)		Yes	180 - 200	30 - 45	2 
		Yes	170 - 190	40 - 60 ***	4 2  
Vols-au-vents/puff pastry crackers		Yes	190 - 200	20 - 30	2 
		Yes	180 - 190	15 - 40 ***	4 2  
Lasagne/baked pasta/ canneloni/flans		Yes	190 - 200	45 - 65	2 
Lamb/veal/beef/pork 1 kg		Yes	190 - 200	80 - 110	2 

FUNCTIONS	 Conventional	 Grill	 Gratin	 Convection Bake
-----------	--	---	--	---

ACCESSORIES	 Wire shelf	 Baking dish or cake tin on the wire shelf	 Baking tray/Drip tray or Baking dish on the wire shelf	 Drip tray / Baking tray	 Drip tray / Baking tray with 200 ml of water
-------------	--	---	--	---	--

RECIPE	FUNCTION	PREHEAT	TEMPERATURE (°C)	DURATION (MIN)	LEVEL AND ACCESSORIES
Roast pork with crackling 2 kg		Yes	180 - 190	110 - 150	2
Chicken/rabbit/duck 1 kg		Yes	200 - 230	50 - 100	2
Turkey/goose 3 kg		Yes	180 - 200	150 - 200	2
Baked fish/en papillote 0.5 kg (fillets, whole)		Yes	170 - 190	30 - 45	2
Stuffed vegetables (tomatoes, courgettes, aubergines)		Yes	180 - 200	50 - 70	2
Toasted bread		5'	250	2 - 6	5
Fish fillets/slices		5'	250	15 - 30 *	4 3
Sausages/kebabs/spare ribs/hamburgers		5'	250	15 - 30 *	5 4
Roast chicken 1-1.3 kg		-	200 - 220	60 - 80 **	3 1
Roast beef rare 1 kg		-	200	35 - 50 **	3
Leg of lamb/knuckle		-	200	60 - 90 **	3
Roast potatoes		-	200 - 220	35 - 55 **	3
Vegetable gratin		-	200 - 220	25 - 55	3
Lasagne and meat		Yes	200	50 - 100 ****	4 1
Meat and potatoes		Yes	190 - 200	45 - 100 ****	4 1
Fish and vegetables		Yes	180	30 - 50 ****	4 2

The time indicated does not include the preheating phase: we recommend placing the food in the oven and setting the cooking time only after the required temperature has been reached.

* Turn food halfway through cooking.

** Turn food two thirds of the way through cooking (if necessary).

*** Switch levels halfway through cooking.

**** Estimated length of time: dishes can be removed from the oven at different times depending on personal preference. Switch shelves two-thirds of the way through cooking, if necessary.

Download the Use and Care Guide from docs.indesit.eu for the table of tested recipes, compiled for the certification authorities in accordance with the standard IEC 60350-1.

FUNCTIONS	Conventional	Grill	Gratin	Convection Bake
ACCESSORIES	Wire shelf	Baking dish or cake tin on the wire shelf	Baking tray/Drip tray or Baking dish on the wire shelf	Drip tray / Baking tray Drip tray / Baking tray with 200 ml of water

MAINTENANCE AND CLEANING



Download the Use and Care Guide from
docs.indesit.eu for more information

Do not use steam cleaning equipment.

Use protective gloves during all operations.

Carry out the required operations with the oven cold.

Disconnect the appliance from the power supply.

Do not use wire wool, abrasive scourers or abrasive/corrosive cleaning agents, as these could damage the surfaces of the appliance.

EXTERIOR SURFACES

Clean the surfaces with a damp microfibre cloth. If they are very dirty, add a few drops of pH-neutral detergent. Finish off with a dry cloth.

Do not use corrosive or abrasive detergents. If any of these products inadvertently comes into contact with the surfaces of the appliance, clean immediately with a damp microfibre cloth.

INTERIOR SURFACES

• After every use, leave the oven to cool and then clean it, preferably while it is still warm, to remove any deposits or stains caused by food residues. To dry any condensation that has formed as a result of cooking foods with a high water content, leave the oven to cool completely and then wipe it with a cloth or sponge.

- The door can be easily removed and refitted to facilitate cleaning of the glass .
- Clean the glass in the door with a suitable liquid detergent.
- The top heating element of the grill can be lowered to clean the upper panel of the oven: Extract the heating element from its seating, then lower it. To return the heating element to its position, lift it up, pull it slightly towards you and make sure that the tab support is in its proper seating.

ACCESSORIES

Soak the accessories in a washing-up liquid solution after use, handling them with oven gloves if they are still hot. Food residues can be removed using a washing-up brush or a sponge.

REMOVING AND REFITTING THE DOOR

1. To remove the door, open it fully and lower the catches until they are in the unlock position.

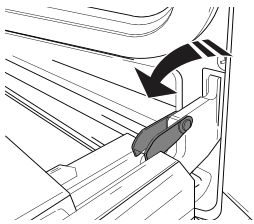

2. Close the door as much as you can. Take a firm hold of the door with both hands – do not hold it by the handle. Simply remove the door by continuing to close it while pulling it upwards (a) at the same time until it is released from its seating (b).

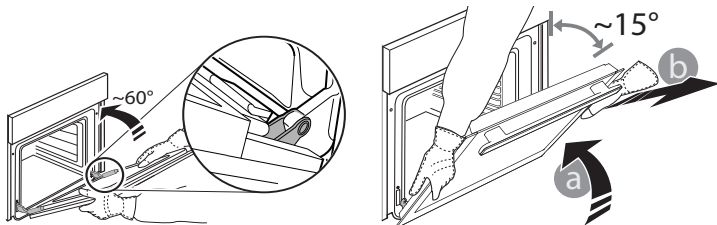

Put the door to one side, resting it on a soft surface.

3. Refit the door by moving it towards the oven, aligning the hooks of the hinges with their seating and securing the upper part onto its seating.

4. Lower the door and then open it fully. Lower the catches into their original position: make sure that you lower them down completely.

5. Try closing the door and check to make sure that it lines up with the control panel. If it does not, repeat the steps above.

CLICK & CLEAN - CLEANING THE GLASS

1. After removing the door and resting it on a soft surface with the handle downwards, simultaneously press the two retaining clips and remove the upper edge of the door by pulling it towards you.

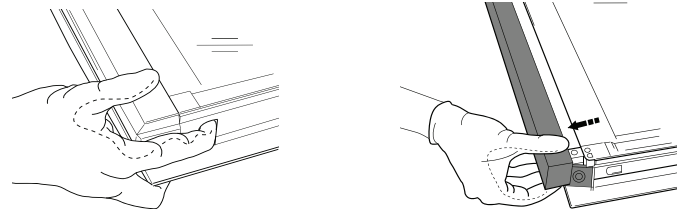

2. Lift and firmly hold the inner glass with both hands, remove it and place it on a soft surface before cleaning it.

3. To correctly reposition the inner glass, make sure that the "R" is visible in the left-hand corner. First insert the long side of the glass indicated by "R" into the support seats, then lower it into position.

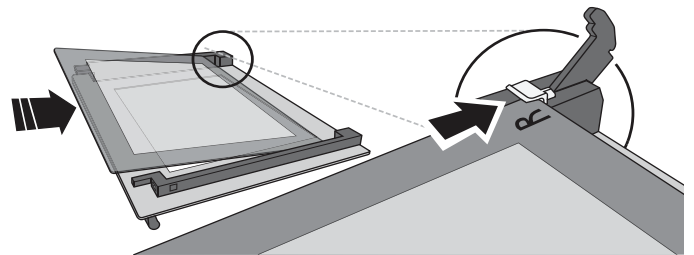

4. Refit the upper edge: a click will indicate correct positioning. Make sure the seal is secure before refitting the door.

Problem	Possible cause	Solution
The oven does not work.	Power cut. Disconnection from the mains.	Check for the presence of mains electrical power and whether the oven is connected to the electricity supply. Turn off the oven and restart it to see if the fault persists.

USEFUL TIPS



Download the Use and Care Guide from docs.indesit.eu for more information

HOW TO READ THE COOKING TABLE

The table lists the best function, accessories and level to use to cook different types of food. Cooking times start from the moment food is placed in the oven, excluding preheating (where required). Cooking temperatures and times are approximate and depend on the amount of food and the type of accessory used. Use the lowest recommended settings to begin with and, if the food is not cooked enough, then switch to higher settings. Use the accessories supplied and preferably dark-coloured metal cake tins and baking trays. You can also use Pyrex or stoneware pans and accessories, but bear in mind that cooking times will be slightly longer.

COOKING DIFFERENT FOODS AT THE SAME TIME

The "Convection Bake" function enables you to cook different foods (such as fish and vegetables) on different shelves at the same time. Switch shelves two-thirds of the way through cooking, if necessary. Remove the food which requires a shorter cooking time and leave the food which requires a longer cooking time in the oven.

PRODUCT FICHE

The product fiche with energy data of this appliance can be downloaded from the website docs.indesit.eu

HOW TO OBTAIN THE USE AND CARE GUIDE

> Download the Use and Care Guide from our website docs.indesit.eu (you can use this QR Code), specifying the product's commercial code.



> Alternatively, contact our Client After-sales Service.

CONTACTING OUR AFTER-SALES SERVICE

You can find our contact details in the warranty manual. When contacting our Client After-sales Service, please state the codes provided on your product's identification plate.

